

# Veritas™ Cluster Server 6.0.1 Bundled Agents Reference Guide - Solaris

# Veritas Cluster Server Bundled Agents Reference Guide

The software described in this book is furnished under a license agreement and may be used only in accordance with the terms of the agreement.

Product version: 6.0.1

Document version: 6.0.1 Rev 2

## Legal Notice

Copyright © 2015 Symantec Corporation. All rights reserved.

Symantec, the Symantec Logo, the Checkmark Logo, Veritas, Veritas Storage Foundation, CommandCentral, NetBackup, Enterprise Vault, and LiveUpdate are trademarks or registered trademarks of Symantec Corporation or its affiliates in the U.S. and other countries. Other names may be trademarks of their respective owners.

The product described in this document is distributed under licenses restricting its use, copying, distribution, and decompilation/reverse engineering. No part of this document may be reproduced in any form by any means without prior written authorization of Symantec Corporation and its licensors, if any.

THE DOCUMENTATION IS PROVIDED "AS IS" AND ALL EXPRESS OR IMPLIED CONDITIONS, REPRESENTATIONS AND WARRANTIES, INCLUDING ANY IMPLIED WARRANTY OF MERCHANTABILITY, FITNESS FOR A PARTICULAR PURPOSE OR NON-INFRINGEMENT, ARE DISCLAIMED, EXCEPT TO THE EXTENT THAT SUCH DISCLAIMERS ARE HELD TO BE LEGALLY INVALID. SYMANTEC CORPORATION SHALL NOT BE LIABLE FOR INCIDENTAL OR CONSEQUENTIAL DAMAGES IN CONNECTION WITH THE FURNISHING, PERFORMANCE, OR USE OF THIS DOCUMENTATION. THE INFORMATION CONTAINED IN THIS DOCUMENTATION IS SUBJECT TO CHANGE WITHOUT NOTICE.

The Licensed Software and Documentation are deemed to be commercial computer software as defined in FAR 12.212 and subject to restricted rights as defined in FAR Section 52.227-19 "Commercial Computer Software - Restricted Rights" and DFARS 227.7202, "Rights in Commercial Computer Software or Commercial Computer Software Documentation", as applicable, and any successor regulations. Any use, modification, reproduction release, performance, display or disclosure of the Licensed Software and Documentation by the U.S. Government shall be solely in accordance with the terms of this Agreement.

Symantec Corporation  
350 Ellis Street  
Mountain View, CA 94043

<http://www.symantec.com>

# Technical Support

Symantec Technical Support maintains support centers globally. Technical Support's primary role is to respond to specific queries about product features and functionality. The Technical Support group also creates content for our online Knowledge Base. The Technical Support group works collaboratively with the other functional areas within Symantec to answer your questions in a timely fashion. For example, the Technical Support group works with Product Engineering and Symantec Security Response to provide alerting services and virus definition updates.

Symantec's support offerings include the following:

- A range of support options that give you the flexibility to select the right amount of service for any size organization
- Telephone and/or Web-based support that provides rapid response and up-to-the-minute information
- Upgrade assurance that delivers software upgrades
- Global support purchased on a regional business hours or 24 hours a day, 7 days a week basis
- Premium service offerings that include Account Management Services

For information about Symantec's support offerings, you can visit our website at the following URL:

[www.symantec.com/business/support/index.jsp](http://www.symantec.com/business/support/index.jsp)

All support services will be delivered in accordance with your support agreement and the then-current enterprise technical support policy.

## Contacting Technical Support

Customers with a current support agreement may access Technical Support information at the following URL:

[www.symantec.com/business/support/contact\\_techsupp\\_static.jsp](http://www.symantec.com/business/support/contact_techsupp_static.jsp)

Before contacting Technical Support, make sure you have satisfied the system requirements that are listed in your product documentation. Also, you should be at the computer on which the problem occurred, in case it is necessary to replicate the problem.

When you contact Technical Support, please have the following information available:

- Product release level
- Hardware information

- Available memory, disk space, and NIC information
- Operating system
- Version and patch level
- Network topology
- Router, gateway, and IP address information
- Problem description:
  - Error messages and log files
  - Troubleshooting that was performed before contacting Symantec
  - Recent software configuration changes and network changes

## Licensing and registration

If your Symantec product requires registration or a license key, access our technical support Web page at the following URL:

[www.symantec.com/business/support/](http://www.symantec.com/business/support/)

## Customer service

Customer service information is available at the following URL:

[www.symantec.com/business/support/](http://www.symantec.com/business/support/)

Customer Service is available to assist with non-technical questions, such as the following types of issues:

- Questions regarding product licensing or serialization
- Product registration updates, such as address or name changes
- General product information (features, language availability, local dealers)
- Latest information about product updates and upgrades
- Information about upgrade assurance and support contracts
- Information about the Symantec Buying Programs
- Advice about Symantec's technical support options
- Nontechnical presales questions
- Issues that are related to CD-ROMs or manuals

## Support agreement resources

If you want to contact Symantec regarding an existing support agreement, please contact the support agreement administration team for your region as follows:

Asia-Pacific and Japan [customercare\\_apac@symantec.com](mailto:customercare_apac@symantec.com)

Europe, Middle-East, and Africa [semea@symantec.com](mailto:semea@symantec.com)

North America and Latin America [supportolutions@symantec.com](mailto:supportsolutions@symantec.com)

## Documentation

Product guides are available on the media in PDF format. Make sure that you are using the current version of the documentation. The document version appears on page 2 of each guide. The latest product documentation is available on the Symantec website.

<https://sort.symantec.com/documents>

Your feedback on product documentation is important to us. Send suggestions for improvements and reports on errors or omissions. Include the title and document version (located on the second page), and chapter and section titles of the text on which you are reporting. Send feedback to:

[doc\\_feedback@symantec.com](mailto:doc_feedback@symantec.com)

For information regarding the latest HOWTO articles, documentation updates, or to ask a question regarding product documentation, visit the Storage and Clustering Documentation forum on Symantec Connect.

<https://www-secure.symantec.com/connect/storage-management/forums/storage-and-clustering-documentation>

## About Symantec Connect

Symantec Connect is the peer-to-peer technical community site for Symantec's enterprise customers. Participants can connect and share information with other product users, including creating forum posts, articles, videos, downloads, blogs and suggesting ideas, as well as interact with Symantec product teams and Technical Support. Content is rated by the community, and members receive reward points for their contributions.

<http://www.symantec.com/connect/storage-management>

# Contents

Technical Support .....	4
Chapter 1	Introducing Bundled agents ..... 18
	About Bundled agents ..... 18
	Resources and their attributes ..... 19
	Modifying agents and their resources ..... 19
	Attributes ..... 19
	Zone-aware agents ..... 20
	IMF aware agents ..... 21
	Enabling debug log messages ..... 21
	VCS support for multi-pathing solutions ..... 22
Chapter 2	Storage agents ..... 24
	About the storage agents ..... 24
	DiskGroup agent ..... 24
	Dependencies for DiskGroup agent ..... 25
	Agent functions for DiskGroup agent ..... 25
	State definitions for DiskGroup agent ..... 27
	Attributes for DiskGroup agent ..... 27
	Resource type definition for DiskGroup agent ..... 32
	Notes for DiskGroup agent ..... 33
	Sample configurations for DiskGroup agent ..... 35
	Debug log levels for DiskGroup agent ..... 35
	DiskGroupSnap agent ..... 36
	Dependencies for DiskGroupSnap agent ..... 36
	Agent functions for DiskGroupSnap agent ..... 37
	State definitions for DiskGroupSnap agent ..... 38
	Attributes for DiskGroupSnap agent ..... 38
	Notes for DiskGroupSnap agent ..... 39
	Resource type definition for DiskGroupSnap agent ..... 43
	Sample configurations for DiskGroupSnap agent ..... 43
	Debug log levels for DiskGroupSnap agent ..... 51
	Disk agent ..... 51
	Dependencies ..... 51
	Agent functions ..... 51

State definitions .....	51
Attributes .....	52
Resource type definition .....	52
Debug log levels .....	52
Volume agent .....	52
Dependencies for Volume agent .....	53
Agent functions for Volume agent .....	53
State definitions for Volume agent .....	53
Attributes for Volume agent .....	54
Resource type definition for Volume agent .....	54
Sample configuration for Volume agent .....	54
Debug log levels for Volume agent .....	55
VolumeSet agent .....	55
Dependencies for VolumeSet agent .....	55
Agent functions for VolumeSet agent .....	55
State definitions for VolumeSet agent .....	56
Attributes for VolumeSet agent .....	56
Resource type definition for VolumeSet agent .....	56
Sample configurations for VolumeSet agent .....	57
Agent notes for VolumeSet agent .....	57
Inaccessible volumes prevent the VolumeSet agent from coming online .....	57
Debug log levels for VolumeSet agent .....	57
Mount agent .....	57
Dependencies for Mount agent .....	58
Agent functions for Mount agent .....	59
State definitions for Mount agent .....	61
Attributes for Mount agent .....	61
Resource type definition for Mount agent .....	67
Notes for Mount agent .....	67
High availability fire drill .....	68
VxFS file system lock .....	68
IMF usage notes .....	69
IPv6 usage notes .....	69
Support for loopback file system .....	69
Enabling Level two monitoring for the Mount agent .....	71
ZFS file system and pool creation example .....	71
Sample configurations for Mount agent .....	72
Debug log levels for Mount agent .....	72
Zpool agent .....	72
Limitations for Zpool agent .....	73
Dependencies for Zpool agent .....	73
Agent functions for Zpool agent .....	73



	State definitions for Zpool agent .....	74
	Attributes for Zpool agent .....	75
	Resource type definition for Zpool agent .....	77
	Sample configurations for Zpool agent .....	78
	Debug log levels for Zpool agent .....	79
<b>Chapter 3</b>	<b>Network agents .....</b>	<b>80</b>
	About the network agents .....	80
	Agent comparisons .....	80
	IP agent .....	82
	High availability fire drill for IP agent .....	82
	Dependencies for IP agent .....	82
	Agent functions for IP agent .....	83
	State definitions for IP agent .....	83
	Attributes for IP agent .....	84
	Resource type definition for IP agent .....	86
	Sample configurations for IP agent .....	87
	Debug log levels for IP agent .....	87
	NIC agent .....	88
	High availability fire drill for NIC agent .....	88
	Dependencies for NIC agent .....	88
	Agent functions for NIC agent .....	89
	State definitions for NIC agent .....	89
	Attributes for NIC agent .....	90
	Resource type definition for NIC agent .....	91
	Sample configurations for NIC agent .....	92
	Exclusive IP Zone configuration for NIC agent .....	93
	Debug log levels for NIC agent .....	94
	IPMultiNIC agent .....	94
	Dependencies for IPMultiNIC agent .....	95
	Agent functions for IPMultiNIC agent .....	95
	State definitions for IPMultiNIC agent .....	95
	Attributes for IPMultiNIC agent .....	96
	Resource type definition for IPMultiNIC agent .....	97
	Sample configuration: IPMultiNIC and MultiNICA .....	98
	Debug log levels .....	99
	MultiNICA agent .....	99
	Dependencies for MultiNICA agent .....	99
	Agent function for MultiNICA agent .....	100
	State definitions for MultiNICA agent .....	100
	Attributes for MultiNICA agent .....	100
	Resource type definition for MultiNICA agent .....	103

Notes for MultiNICA agent .....	104
Using RouteOptions for MultiNICA agent .....	104
Sample configurations for MultiNICA agent .....	105
Debug log levels for MultiNICA agent .....	107
About the IPMultiNICB and MultiNICB agents .....	107
Checklist to ensure the proper operation of MultiNICB .....	107
IPMultiNICB agent .....	108
Dependencies for IPMultiNICB agent .....	109
Requirements for IPMultiNICB .....	109
Agent functions for IPMultiNICB agent .....	109
State definitions for IPMultiNICB agent .....	110
Attributes for IPMultiNICB agent .....	110
Resource type definition for IPMultiNICB agent .....	113
Manually migrating a logical IP address for IPMultiNICB agent .....	113
Sample configurations for IPMultiNICB agent .....	114
Debug log levels for IPMultiNICB agent .....	114
MultiNICB agent .....	114
Base and Multi-pathing modes for MultiNICB agent .....	115
Oracle trunking for MultiNICB agent .....	115
The haping utility for MultiNICB agent .....	115
Dependencies for MultiNICB agent .....	115
Agent functions for MultiNICB agent .....	116
State definitions for MultiNICB agent .....	116
Attributes for MultiNICB agent .....	116
Optional attributes for Base and Mpathd modes for MultiNICB agent .....	118
Optional attributes for Base mode for MultiNICB agent .....	119
Optional attributes for Multi-pathing mode for MultiNICB agent .....	123
Resource type definition for MultiNICB agent .....	124
Solaris operating modes: Base and Multi-Pathing for MultiNICB agent .....	125
Base mode for MultiNICB agent .....	125
Failover and failback for MultiNICB agent .....	126
Multi-Pathing mode for MultiNICB agent .....	126
Configuring MultiNICB and IPMultiNICB agents on Solaris 11 .....	127
Trigger script for MultiNICB agent .....	127
Sample configurations for MultiNICB agent .....	128
Debug log levels for MultiNICB agent .....	131
DNS agent .....	131
Dependencies for DNS agent .....	131

	Agent functions for DNS agent .....	132
	State definitions for DNS agent .....	133
	Attributes for DNS agent .....	134
	Resource type definition for DNS agent .....	140
	Agent notes for DNS agent .....	140
	Sample configurations for DNS agent .....	145
	Debug log levels for DNS agent .....	147
<b>Chapter 4</b>	<b>File share agents .....</b>	<b>148</b>
	About the file service agents .....	148
	NFS agent .....	148
	Dependencies for NFS agent .....	149
	Agent functions for NFS agent .....	149
	State definitions for NFS agent .....	150
	Attributes for NFS agent .....	150
	Resource type definition for NFS agent .....	151
	Notes for NFS agent .....	152
	Sample configurations for NFS agent .....	153
	Debug log levels for NFS agent .....	153
	NFSRestart agent .....	154
	Dependencies for NFSRestart agent .....	154
	Agent functions for NFSRestart agent .....	155
	State definitions .....	156
	Attributes for NFSRestart agent .....	157
	Resource type definition for NFSRestart agent .....	158
	Notes for NFSRestart agent .....	158
	Sample configurations for NFSRestart agent .....	161
	Debug log levels for NFSRestart agent .....	162
	Share agent .....	162
	Dependencies for Share agent .....	163
	Agent functions for Share agent .....	163
	State definitions for Share agent .....	164
	Attributes for Share agent .....	164
	Resource type definition for Share agent .....	165
	Notes for Share agent .....	165
	Sample configurations for Share agent .....	165
	Debug log levels for Share agent .....	165
	About the Samba agents .....	166
	The Samba agents .....	166
	Before using the Samba agents .....	166
	Supported versions for Samba agents .....	167
	Notes for configuring the Samba agents .....	167

SambaServer agent .....	168
Dependencies for SambaServer agent .....	168
Agent functions for SambaServer agent .....	168
State definitions for SambaServer agent .....	168
Attributes for SambaServer agent .....	169
Resource type definitions for SambaServer agent .....	171
Sample configurations for SambaServer agent .....	171
Debug log levels for SambaServer agent .....	171
SambaShare agent .....	171
Dependencies for SambaShare agent .....	172
Agent functions for SambaShare agent .....	172
State definitions for SambaShare agent .....	172
Attributes for SambaShare agent .....	173
Resource type definition for SambaShare agent .....	173
Sample configuration for SambaShare agent .....	173
Debug log levels for SambaShare agent .....	174
NetBios agent .....	174
Dependencies for NetBios agent .....	174
Agent functions for NetBios agent .....	175
State definitions for NetBios agent .....	175
Attributes for NetBios agent .....	176
Resource type definition for NetBios agent .....	177
Sample configuration for NetBios agent .....	177
Debug log levels for NetBios agent .....	178
 Chapter 5	
Service and application agents .....	179
About the services and applications agents .....	179
Apache HTTP server agent .....	179
Dependencies .....	180
Agent functions .....	181
State definitions .....	181
Attributes .....	182
Resource type definition .....	186
Apache HTTP server notes .....	187
Sample configurations .....	190
Application agent .....	192
High availability fire drill for Application agent .....	193
Dependencies for Application agent .....	193
Agent functions for Application agent .....	193
State definitions for Application agent .....	195
Attributes for Application agent .....	196
Resource type definition for Application agent .....	199

Notes for Application agent .....	200
Sample configurations for Application agent .....	202
Debug log levels for Application agent .....	203
CoordPoint agent .....	203
Coordination Point server as a coordination point .....	204
SCSI-3 based disk as a coordination point .....	204
Dependencies .....	204
Agent functions .....	205
State definitions .....	205
Attributes .....	206
Resource type definition .....	206
Notes for the CoordPoint agent .....	206
Sample configuration .....	207
Debug log levels .....	208
Process agent .....	208
High availability fire drill for Process agent .....	209
Dependencies for Process agent .....	209
Agent functions for Process agent .....	209
State definitions for Process agent .....	210
Attributes for Process agent .....	210
Resource type definition for Process agent .....	211
Usage notes for Process agent .....	211
Sample configurations for Process agent .....	211
Debug log levels for Process agent .....	212
ProcessOnOnly agent .....	212
Dependencies .....	213
Agent functions .....	213
State definitions .....	213
Attributes .....	214
Resource type definition .....	214
ProcessOnOnly agent usage notes .....	215
Sample configurations .....	215
Debug log levels .....	215
Zone agent .....	215
Dependencies .....	216
Agent functions .....	218
Attributes .....	219
Configuring the Zone agent for DR in a Global Cluster environment .....	223
Resource type definition .....	223
Zone agent notes .....	223
Using the Zone agent with IMF .....	224
Sample configurations .....	224

Debug log levels .....	225
LDom agent .....	226
Configuring primary and guest domain dependencies and failure policy .....	226
Dependencies .....	226
Agent functions .....	227
State definitions .....	227
Attributes .....	228
Configuring the LDom agent for DR in a Global Cluster environment .....	232
Resource type definition .....	232
LDom agent notes .....	233
About the auto-boot? variable .....	233
Sample configurations .....	233
Sample configuration 2 .....	233
Configuration (future LDom migration) .....	234
Debug log levels .....	234
Project agent .....	234
Dependencies .....	234
Agent functions .....	235
Attributes .....	235
Resource type definition .....	236
Sample configuration .....	236
Debug log levels .....	237
AlternatelIO agent .....	237
Dependencies for AlternatelIO agent .....	237
Agent functions for AlternatelIO agent .....	238
State definitions for AlternatelIO agent .....	238
Attributes for AlternatelIO agent .....	239
Resource type definition for AlternatelIO agent .....	240
Sample configurations for AlternatelIO agent .....	240
Debug log levels for AlternatelIO agent .....	243
Chapter 6      Infrastructure and support agents .....	244
About the infrastructure and support agents .....	244
NotifierMngr agent .....	244
Dependency .....	245
Agent functions .....	245
State definitions .....	245
Attributes .....	245
Resource type definition .....	248
Sample configuration .....	249

Debug log levels .....	250
Proxy agent .....	250
Dependencies .....	250
Agent functions .....	251
Attributes .....	251
Resource type definition .....	252
Sample configurations .....	252
Debug log levels .....	253
Phantom agent .....	253
Dependencies .....	254
Agent functions .....	254
Resource type definition .....	254
Sample configurations .....	254
RemoteGroup agent .....	255
Dependency .....	256
Agent functions .....	256
State definitions .....	256
Attributes .....	257
Resource type definition .....	262
Debug log levels .....	262

## Chapter 7

Testing agents .....	263
About the testing agents .....	263
ElifNone agent .....	263
Dependencies for ElifNone agent .....	263
Agent function for ElifNone agent .....	264
State definitions for ElifNone agent .....	264
Attributes for ElifNone agent .....	264
Resource type definition for ElifNone agent .....	265
Sample configuration for ElifNone agent .....	265
Debug log levels for ElifNone agent .....	265
FileNone agent .....	265
Dependencies for FileNone agent .....	265
Agent functions for FileNone agent .....	266
State definitions for FileNone agent .....	266
Attribute for FileNone agent .....	266
Resource type definition for FileNone agent .....	267
Sample configuration for FileNone agent .....	267
Debug log levels for FileNone agent .....	267
FileOnOff agent .....	267
Dependencies for FileOnOff agent .....	267
Agent functions for FileOnOff agent .....	268

State definitions for FileOnOff agent .....	268
Attribute for FileOnOff agent .....	269
Resource type definition for FileOnOff agent .....	269
Sample configuration for FileOnOff agent .....	269
Debug log levels for FileOnOff agent .....	269
FileOnOnly agent .....	269
Dependencies for FileOnOnly agent .....	269
Agent functions for FileOnOnly agent .....	270
State definitions for FileOnOnly agent .....	270
Attribute for FileOnOnly agent .....	271
Resource type definition for FileOnOnly agent .....	271
Sample configuration for FileOnOnly agent .....	271
Debug log levels for FileOnOnly agent .....	271

Chapter 8	Replication agents .....	272
	About the replication agents .....	272
	RVG agent .....	272
	Dependencies .....	273
	Agent functions .....	274
	State definitions .....	274
	Attributes .....	274
	Resource type definitions .....	275
	Sample configurations .....	275
	RVGPrimary agent .....	276
	Dependencies .....	276
	Agent functions .....	277
	State definitions .....	278
	Attributes .....	278
	Resource type definitions .....	281
	Sample configurations .....	282
	RVGSnapshot .....	282
	Dependencies .....	283
	Agent functions .....	283
	State definitions .....	283
	Attributes .....	284
	Resource type definitions .....	284
	Sample configurations .....	285
	RVGShared agent .....	285
	Dependencies .....	285
	Agent functions .....	286
	State definitions .....	286
	Attributes .....	287



Resource type definitions .....	287
Sample configurations .....	287
RVGLogowner agent .....	287
Dependencies .....	288
Agent functions .....	288
State definitions .....	289
Attributes .....	289
Resource type definitions .....	290
RVGLogowner agent notes .....	290
Sample configurations .....	291
RVGSharedPri agent .....	291
Dependencies .....	292
Agent functions .....	292
State definitions .....	293
Attributes .....	293
Resource type definitions .....	294
Sample configurations .....	294
Index .....	295

# Introducing Bundled agents

This chapter includes the following topics:

- [About Bundled agents](#)
- [Resources and their attributes](#)
- [Modifying agents and their resources](#)
- [Attributes](#)
- [Zone-aware agents](#)
- [IMF aware agents](#)
- [Enabling debug log messages](#)
- [VCS support for multi-pathing solutions](#)

## About Bundled agents

Bundled agents are Veritas Cluster Server (VCS) processes that manage resources of predefined resource types according to commands received from the VCS engine, HAD. You install these agents when you install VCS.

A node has one agent per resource type that monitors all resources of that type. For example, a single IP agent manages all IP resources.

When the agent starts, it obtains the necessary configuration information from VCS. The agent then periodically monitors the resources, and updates VCS with the resource status.

Agents can:

- Bring resources online.
- Take resources offline.

- Monitor resources and report state changes.

For a more detailed overview of how agents work, refer to the *Veritas Cluster Server Administrator's Guide*.

## Resources and their attributes

Resources are parts of a system. They are known by their types, for example: a volume, a disk group, or an IP address. VCS includes a set of resource types. Different attributes define these resource types in the `types.cf` file. Each type has a corresponding agent that controls the resource.

The VCS configuration file, `main.cf`, contains the values for the resource attributes and has an `include` directive to the `types.cf` file.

An attribute's given value configures the resource to function in a specific way. By modifying the value of a resource attribute, you can change the way the VCS agent manages the resource. For example, the IP agent uses the `Address` attribute to determine the IP address to monitor.

## Modifying agents and their resources

Use the Cluster Manager (Java Console), Veritas Operations Manager, or the command line to dynamically modify the configuration of the resources managed by an agent.

VCS enables you to edit the `main.cf` file directly. To implement these changes, make sure to restart VCS.

See the *Veritas Cluster Server Administrator's Guide* for instructions on how to complete these tasks.

## Attributes

Attributes contain data about the cluster, systems, service groups, resources, resource types, and the agent. An attribute has a definition and a value. You change attribute values to configure VCS resources. Attributes are either optional or required, although sometimes attributes that are optional in one configuration might be required in other configurations. Many optional attributes have predefined or default values, which you should change as required.

A variety of internal use only attributes also exist. Do not modify these attributes—modifying them can lead to significant problems for your clusters.

Attributes have type and dimension. Some attribute values can accept numbers, others can accept alphanumeric values or groups of alphanumeric values, while others are simple boolean on/off values.

**Table 1-1** Attribute data types

Data Type	Description
string	Enclose strings, which are a sequence of characters, in double quotes (""). Optionally enclose strings in quotes when they begin with a letter, and contains only letters, numbers, dashes (-), and underscores (_).  A string can contain double quotes, but the quotes must be immediately preceded by a backslash. In a string, represent a backslash with two backslashes (\\).
integer	Signed integer constants are a sequence of digits from 0 to 9. You can precede them with a dash. They are base 10. Integers cannot exceed the value of a 32-bit signed integer: 2147483647.
boolean	A boolean is an integer with the possible values of 0 (false) and 1 (true).

**Table 1-2** Attribute dimensions

Dimension	Description
scalar	A scalar has only one value. This is the default dimension.
vector	A vector is an ordered list of values. Each value is indexed using a positive integer beginning with zero. A set of brackets ([]) denotes that the dimension is a vector. Find the specified brackets after the attribute name on the attribute definition in the types.cf file.
keylist	A keylist is an unordered list of unique strings.
association	An association is an unordered list of name-value pairs. An equal sign separates each pair. A set of braces ({} ) denotes that an attribute is an association. Braces are specified after the attribute name on the attribute definition in the types.cf file, for example: str SnmpConsoles{}

## Zone-aware agents

Table 1-3 lists the ContainerOpts attribute default values for resource types. Symantec recommends that you do not modify these values.

**Table 1-3** ContainerOpts attribute default values for applications and resource types

Resource Type	RunInContainer	PassCInfo
Application	1	0
Apache	1	0
IP	0	1
IPMultiNIC	0	1
IPMultiNICB	0	1
Mount	0	0
NIC	0	1
Process	1	0
Zone	0	1
ProcessOnOnly	1	0
Project	0	1

For more information on using zones in your VCS environment, refer to the *Veritas Storage Foundation and High Availability Solutions Virtualization Guide*.

## IMF aware agents

- Application agent. See [“Application agent”](#) on page 192.
- DiskGroup agent. See [“DiskGroup agent”](#) on page 24.
- Mount agent. See [“Mount agent”](#) on page 57.
- Process agent. See [“Process agent”](#) on page 208.
- Zone agent. See [“Zone agent”](#) on page 215.

## Enabling debug log messages

To help troubleshoot agent issues, you can enable debug log messages in the agent framework as well as the agents.

To enable agent framework debug log messages:

```
# hatype -modify agent_name LogDbg -add DBG_AGDEBUG DBG_AGINFO  
DBG_AGTRACE
```

For example:

```
# hatype -modify Mount LogDbg -add DBG_AGDEBUG DBG_AGINFO DBG_AGTRACE
```

To enable agent-specific debug log messages:

```
# hatype -modify agent_name LogDbg -add debug_log_levels
```

For example:

```
# hatype -modify Mount LogDbg -add DBG_1 DBG_2 DBG_3 DBG_4 DBG_5 DBG_6
```

Alternatively, you can also use the following command:

```
# hatype -modify Mount LogDbg -add 1 2 3 4 5 6
```

Agent-specific debug log level information is specified in the agent's description. For example, for information about the Mount agent, See [“Debug log levels for Mount agent”](#) on page 72.

## VCS support for multi-pathing solutions

This section applies to the Zpool agent only.

VCS supports Symantec Dynamic Multi-Pathing (DMP) that is included as a part of the Storage Foundation and High Availability (SFHA) suite of products. Symantec does not support multi-pathing solutions that are not explicitly listed in the hardware compatibility list (HCL). You can find the HCL on the SORT web site, under the Documentation tab. However, Symantec supports third-party solutions, which are included as a part of the operating systems.

Symantec aims to thoroughly test and support third-party and native solutions, but it is not possible to test all third-party multi-pathing applications. This is because of complex support matrix and a number of potential product combinations. Hence, Symantec does not officially support multi-pathing solutions that are not explicitly listed in the HCL. Also, advanced functionality such as I/O fencing with SCSI3-PGR is only supported with arrays and multi-pathing solutions listed in the HCL and only with Symantec Storage Foundation.

If you are using a third-party multi-pathing solution, Symantec understands your need of keeping data paths redundant and does not insist that you uninstall or disable the solution. Symantec does not consider third-party multi-pathing solutions as invalid and continues to troubleshoot any support issues. However, for persisting

support issues related to multi-pathing solutions, you need to contact the multi-pathing vendor.

# Storage agents

This chapter includes the following topics:

- [About the storage agents](#)
- [DiskGroup agent](#)
- [DiskGroupSnap agent](#)
- [Disk agent](#)
- [Volume agent](#)
- [VolumeSet agent](#)
- [Mount agent](#)
- [Zpool agent](#)

## About the storage agents

Storage agents monitor shared storage and make shared storage highly available. Storage includes shared disks, disk groups, volumes, and mounts.

## DiskGroup agent

The DiskGroup agent brings online, takes offline, and monitors Veritas Volume Manager (VxVM) disk groups. This agent uses VxVM commands. You can use this agent to monitor or make disk groups highly available.

When the value of the StartVolumes and StopVolumes attribute is 1, the DiskGroup agent brings the volumes online and takes them offline during the import and deport operations of the disk group.



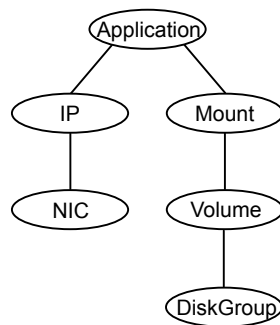
This agent is IMF-aware and uses asynchronous monitoring framework (AMF) kernel driver for IMF notification. For more information about the Intelligent Monitoring Framework (IMF) and intelligent resource monitoring, refer to the *Veritas Cluster Server Administrator's Guide*.

For important information on this agent, See [“Notes for DiskGroup agent”](#) on page 33.

## Dependencies for DiskGroup agent

The DiskGroup resource does not depend on any other resources.

**Figure 2-1** Sample service group that includes a DiskGroup resource



## Agent functions for DiskGroup agent

Online	Imports the disk group using the <code>vx dg</code> command.
Offline	Deports the disk group using the <code>vx dg</code> command.
Monitor	<p>Determines if the disk group is online or offline using the <code>vx dg</code> command. The Monitor function changes the value of the VxVM <code>noautoimport</code> flag from off to on. This action allows VCS to maintain control of importing the disk group. The monitor function uses following command to set the <code>noautoimport</code> flag to on.</p> <pre># vx dg -g disk_group set autoimport=no</pre> <p>If IMF is enabled for the DiskGroup agent, the resource is monitored asynchronously and any change in the disk group state is immediately sent to the DiskGroup agent for appropriate action.</p>
Clean	Terminates all ongoing resource actions and takes the resource offline—forcibly when necessary.

Info	<p>The DiskGroup info agent function gets information from the Volume Manager and displays the type and free size for the DiskGroup resource.</p> <p>Initiate the info agent function by setting the InfoInterval timing to a value greater than 0.</p> <p>In the following example, the info agent function executes every 60 seconds:</p> <pre># haconf -makerw  # hatype -modify DiskGroup InfoInterval 60</pre> <p>The command to retrieve information about the DiskType and FreeSize of the DiskGroup resource is:</p> <pre># hares -value diskgroupres ResourceInfo</pre> <p>Output includes:</p> <pre>DiskType sliced FreeSize 35354136</pre> <p>The value specified is in kilo bytes.</p>
Action	<p>Different action agent functions follow:</p> <ul style="list-style-type: none"><li>■ license.vfd Checks for valid Veritas Volume manager license—if one is not found use the vxlicinst utility to install a valid license key.</li><li>■ disk.vfd Checks if all disks in diskgroup are visible on host—if it fails, check if the path to disks exists from the host and check if LUN masking and zoning are set properly.</li><li>■ udid.vfd Checks the UDIDs (unique disk identifiers) of disks on the cluster nodes—if it fails, ensure that the disks that are used for the disk group are the same on all cluster nodes.</li><li>■ verifyplex.vfd Checks if the number of plexes on each site for the Campus Cluster setup are set properly—if it fails, check that the sites, disks, and plexes are set properly for a Campus Cluster setup.</li><li>■ volinuse Checks if open volumes are in use or file systems on volumes that are mounted outside of VCS configuration.</li></ul> <p>See <a href="#">“High availability fire drill”</a> on page 33.</p>

imf_init	Initializes the agent to interface with Intelligent monitoring framework (IMF). The function runs when the agent starts up.
imf_getnotification	Waits for notification about disk group state changes. The function runs after the agent initializes with IMF. The function waits for notification. Upon receiving notification, the agent takes action on the resource.
imf_register	Registers the resource entities, which the agent must monitor using IMF. The function runs for each resource after the resource goes into a steady state, either online or offline.

## State definitions for DiskGroup agent

ONLINE	Indicates that the disk group is imported.
OFFLINE	Indicates that the disk group is not imported.
FAULTED	Indicates that the disk group has unexpectedly deported or become disabled.
UNKNOWN	Indicates that a problem exists either with the configuration or the ability to determine the status of the resource. One cause of this state is when I/O fencing is not configured—the cluster level attribute UseFence is not set to "SCSI3" but the Reservation attribute value is "SCSI3".

## Attributes for DiskGroup agent

**Table 2-1** Required attributes

Required attribute	Description
DiskGroup	Name of the disk group that is configured with Veritas Volume Manager. Type and dimension: string-scalar

Table 2-2 Optional attributes

Optional attributes	Description
MonitorReservation	<p>If the value is 1, and SCSI-3 fencing is used, the agent monitors the SCSI reservation on the disk group. If the reservation is missing, the monitor agent function takes the service group containing the resource offline.</p> <p>Type and dimension: boolean-scalar</p> <p>Default: 0</p> <p><b>Note:</b> If the MonitorReservation attribute is set to 0, and the value of the clusterwide attribute UseFence is set to SCSI3, and the disk group is imported without SCSI reservation, then the monitor agent function takes the service group containing the resource offline.</p>

**Table 2-2** Optional attributes (*continued*)

Optional attributes	Description
PanicSystemOnDGLoss	

Table 2-2 Optional attributes (*continued*)

Optional attributes	Description
	<p>Determines whether to panic the node if the disk group becomes disabled or monitor operation times out. A loss of storage connectivity can cause the disk group to become disabled. VxVM commands not responding properly can cause monitor operation to timeout.</p> <p><b>Note:</b> System administrators may want to set a high value for FaultOnMonitorTimeout to increase system tolerance.</p> <p>This attribute accepts following values 0, 1, 2,3</p> <ul style="list-style-type: none"> <li>■ 0: Do not halt the system</li> <li>■ 1: halt the system if either disk group goes into disabled state or the disk group resource faults due to monitor timeout</li> <li>■ 2: halt the system only if disk group goes into disabled state</li> <li>■ 3: halt the system only if disk group resource faults due to monitor timeout</li> </ul> <p>If the value of the attribute is 0, and the disk group becomes disabled, the following occurs:</p> <ul style="list-style-type: none"> <li>■ If the cluster has I/O fencing enabled (Cluster level attribute UseFence set to SCSI3), the monitor operation on the DiskGroup resource is reported OFFLINE. This results in the agent to call clean to take the DiskGroup resource offline.</li> </ul> <p>As part of bringing the DiskGroup resource offline, the agent attempts to deport the disabled disk group. The clean operation succeeds even if the disabled disk group fails to deport and the DiskGroup resource enters into FAULTED state. This state enables the failover of the service group that contains the DiskGroup resource. To fail back the service group containing the DiskGroup resource, manually deport the disk group after restoring storage connectivity on the failed node.</p> <ul style="list-style-type: none"> <li>■ If the cluster does not use I/O fencing, a message is logged and the resource is reported ONLINE. The resource is reported ONLINE so that it does not fail over, which ensures data integrity.</li> </ul> <p>Notes:</p> <ul style="list-style-type: none"> <li>■ The PanicSystemOnDGLoss attribute does not depend on the MonitorReservation attribute.</li> </ul>

Table 2-2 Optional attributes (*continued*)

Optional attributes	Description
	<ul style="list-style-type: none"><li>■ Symantec recommends to configure volume resource for each volume in the diskgroup to detect storage connectivity loss more effectively.</li><li>■ If PanicSystemOnDGLoss is set to non-zero value, the system panic is initiated using <code>uadmin 5 0</code> command. This command halts the system. An administrator needs to bring up the system.</li></ul> Type and dimension: integer-scalar Default: 0
StartVolumes	If value of this attribute is 1, the DiskGroup online function starts all volumes belonging to that disk group after importing the group.  Note: With VxVM version 5.1.100.0 onwards, if the Veritas Volume Manager default <code>autostartvolumes</code> at system level is set to on, all the volumes of the disk group will be started as a part of the import disk group.  Type and dimension: boolean-scalar Default: 1
StopVolumes	If value is 1, the DiskGroup offline function stops all volumes belonging to that disk group before it deports the disk group.  Type and dimension: boolean-scalar Default: 1
UmountVolumes	This attribute enables the DiskGroup resource to forcefully go offline even if open volumes are mounted outside of VCS control. When the value of this attribute is 1 and the disk group has open volumes, the following occurs: <ul style="list-style-type: none"><li>■ The agent attempts to unmount the file systems on open volumes. If required, the agent attempts to kill all VCS managed and un-managed applications using the file systems on those open volumes.</li><li>■ The agent attempts to forcefully unmount the file systems to close the volumes.</li></ul> Type and dimension: integer-scalar Default: 0

**Table 2-2** Optional attributes (*continued*)

Optional attributes	Description
Reservation	<p>Determines if you want to enable SCSI-3 reservation. This attribute can have one of the following three values:</p> <ul style="list-style-type: none"> <li>■ ClusterDefault—The disk group is imported with SCSI-3 reservation if the value of the cluster-level UseFence attribute is SCSI3. If the value of the cluster-level UseFence attribute is NONE, the disk group is imported without reservation.</li> <li>■ SCSI3—The disk group is imported with SCSI-3 reservation if the value of the cluster-level UseFence attribute is SCSI3.</li> <li>■ NONE—The disk group is imported without SCSI-3 reservation.</li> </ul> <p>Type and dimension: string-scalar</p> <p>Default: ClusterDefault</p> <p>Example: "SCSI3"</p>

**Table 2-3** Internal attributes

Attribute	Description
tempUseFence	Do not use. For internal use only.
NumThreads	<p>The number of threads that are used within the agent process for managing resources. This number does not include the number of threads that are used for other internal purposes.</p> <p>Setting the NumThreads attribute to a higher value may decrease the time required to go online or the time required to monitor a large number of DiskGroup resources.</p> <p>Type and dimension: static integer-scalar</p> <p>Default: 1</p> <p><b>Note:</b> If there are many DiskGroup resources and if the resources are taking more time to come online, consider increasing the NumThreads attribute to a value greater than 1.</p>
DiskGroupType	The attribute is deprecated.

## Resource type definition for DiskGroup agent

The resource definition for this agent on Solaris follows:



```
type DiskGroup (
  static keylist SupportedActions = { "license.vfd", "disk.vfd", "udid.vfd",
  "verifyplex.vfd", checkudid, numdisks, campusplex, volinuse,
  joinidg, splitdg, getvxvminfo }
  static int OnlineRetryLimit = 1
  static str ArgList[] = { DiskGroup, StartVolumes, StopVolumes, MonitorOnly,
  MonitorReservation, tempUseFence, PanicSystemOnDGLoss, DiskGroupType,
  UmountVolumes, Reservation, ConfidenceLevel }
  static str IMFRegList[] = { DiskGroup, Reservation }
  static int IMF{} = { Mode = 3, MonitorFreq = 5, RegisterRetryLimit = 3 }
  str DiskGroup
  boolean StartVolumes = 1
  boolean StopVolumes = 1
  static int NumThreads = 1
  boolean MonitorReservation = 0
  temp str tempUseFence = INVALID
  int PanicSystemOnDGLoss = 0
  str DiskGroupType = private
  int UmountVolumes = 0
  str Reservation = ClusterDefault
)
```

## Notes for DiskGroup agent

The DiskGroup agent has the following notes:

- [High availability fire drill](#)
- [Using volume sets](#)
- [Setting the noautoimport flag for a disk group](#)
- [Configuring the Fiber Channel adapter](#)
- [Using the DiskGroup agent with IMF](#)

### High availability fire drill

The high availability fire drill detects discrepancies between the VCS configuration and the underlying infrastructure on a node. These discrepancies might prevent a service group from going online on a specific node.

For DiskGroup resources, the high availability fire drill checks for:

- The Veritas Volume Manager license
- Visibility from host for all disks in the disk group

- The same disks for the disk group on cluster nodes
- Equal number of plexes on all sites for the disk group in a campus cluster setup

For more information about using the high availability fire drill see the *Veritas Cluster Server Administrator's Guide*.

## Using volume sets

When you use a volume set, set `StartVolumes` and `StopVolumes` attributes of the `DiskGroup` resource that contains a volume set to 1. If a file system is created on the volume set, use a `Mount` resource to mount the volume set.

See the `Mount` agent description for more information.

## Setting the `noautoimport` flag for a disk group

VCS requires that the `noautoimport` flag of an imported disk group be explicitly set to true. This value enables VCS to control the importation and deportation of disk groups as needed when bringing disk groups online and taking them offline.

### To check the status of the `noautoimport` flag for an imported disk group

```
◆ # vxprint -l disk_group | grep noautoimport
```

If the output from this command is blank, the `noautoimport` flag is set to false and VCS lacks the necessary control.

The `Monitor` function changes the value of the VxVM `noautoimport` flag from off to on. It changes the value instead of taking the service group offline. This action allows VCS to maintain control of importing the disk group.

The following command changes the `autoimport` flag to false:

```
# vxdg -g disk_group set autoimport=no
```

## For VxVM versions 4.1 and 5.0 or later

The `Monitor` function changes the value of the VxVM `noautoimport` flag from off to on. It changes the value instead of taking the service group offline. This action allows VCS to maintain control of importing the disk group.

The following command changes the `autoimport` flag to false:

```
# vxdg -g disk_group set autoimport=no
```

## Configuring the Fiber Channel adapter

Most Fiber Channel (FC) drivers have a configurable parameter called "failover". This configurable parameter is in the FC driver's configuration file. This parameter is the number of seconds that the driver waits before it transitions a disk target from OFFLINE to FAILED. After the state becomes FAILED, the driver flushes all pending fiber channel commands back to the application with an error code. Symantec recommends that you use a non-zero value that is smaller than any of the MonitorTimeout values of the Disk Group resources. Use this value to avoid excessive waits for monitor timeouts.

Refer to the *Veritas™ Dynamic Multi-Pathing Administrator's Guide* for more information.

Refer to the *Fiber Channel adapter's configuration guide* for further information.

## Using the DiskGroup agent with IMF

Considerations to use the DiskGroup agent with IMF:

- You can either set the MonitorFreq to 0 or a high value. Setting the value of the MonitorFreq key to a high value ensures that the agent does not run the monitor function frequently. Setting the MonitorFreq key to 0 disables the traditional monitoring while IMF monitoring is in progress. Traditional monitoring is done after receiving the notification for a resource.  
However, if the disk group is configured with reservation and value of the MonitorReservation attribute is set to 1, then set the MonitorFreq key value to the frequency at which you want the agent to run the monitor function, to verify the reservation on the disk group.

## Sample configurations for DiskGroup agent

### DiskGroup resource configuration

Sample configuration of the DiskGroup resource:

```
DiskGroup dg1 (  
    DiskGroup = testdg_1  
)
```

## Debug log levels for DiskGroup agent

The DiskGroup agent uses the following debug log levels:

DBG\_1, DBG\_4, DBG\_5

# DiskGroupSnap agent

Use the DiskGroupSnap agent to perform fire drills in a campus cluster. The DiskGroupSnap agent enables you to verify the configuration and data integrity in a Campus Cluster environment with VxVM stretch mirroring. The agent also supports SCSI-3 fencing.

---

**Note:** The DiskGroupSnap agent requires the Global Cluster Option (GCO) license enabled on all systems in the cluster.

---

For more information on fire drills, refer to the *Veritas Cluster Server Administrator's Guide*.

You must define the DiskGroupSnap agent in a separate FireDrill service group which is similar to the Application service group. The FireDrill service group might contain resources similar to the Application service group, for example Mount, Application, and so on.

The FireDrill service group must also contain a resource of type DiskGroupSnap such that the Mount resource depends on the DiskGroupSnap resource. The main DiskGroup must contain multiple sites registered in it with the value of the "siteconsistent" attribute set to on.

When the DiskGroupSnap agent goes online, the agent detaches one of the sites from the main DiskGroup and imports the detached site on the fire drill host as an independent DiskGroup with a different name. The volumes on the DiskGroup are also imported and mounted with same names on the fire drill host.

The DiskGroupSnap agent provides Gold and Bronze configurations for the fire drill, which can be specified using the agent's FDType attribute. The configuration decides the site to be detached from the DiskGroup for fire drill testing. The Gold configuration is the default option in which the agent selects a site from the DiskGroup that is neither the local VxVM site nor the site on which the DiskGroup is online. With the Gold configuration, you can also specify an alternate site to detach through the agent's FDSiteName attribute. With the Bronze configuration, the agent uses the local VxVM site name as the site to detach from the DiskGroup.

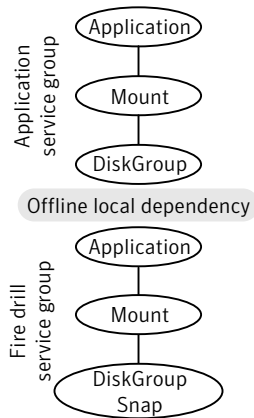
For important information about this agent, See ["Notes for DiskGroupSnap agent"](#) on page 39.

## Dependencies for DiskGroupSnap agent

The DiskGroupSnap resource does not depend on any other resources. The service group that contains the DiskGroupSnap agent's resource has an offline local dependency on the application's service group. The offline local dependency is to

make sure the firedrill service group and the application service group are not online at the same site at the same time.

**Figure 2-2** Sample service group that includes a DiskGroupSnap resource



## Agent functions for DiskGroupSnap agent

Online	Verifies that the application's disk group is in a valid campus cluster configuration. It detaches the site that the value of the FDSiteName attribute specifies. It then creates another disk group to be used for the fire drill on the detached site. After the completion of Online function, the agent creates a lock file in the lock directory (/var/VRTSvcs/lock) to indicate that the resource is online.
Offline	This re-attaches the site that the value of the FDSiteName attribute specifies back to the application's disk group. After the completion of Offline function the agent removes the lock file from the lock directory (/var/VRTSvcs/lock) to indicate that the resource is Offline.
Monitor	Monitors the DiskGroupSnap resource by checking the existence of the Lock file in /var/VRTSvcs/lock directory..
Clean	Takes the DiskGroupSnap resource offline.
Open	If the DiskGroupSnap resource has a parent resource that is not ONLINE, then it deletes the online lock file of the DiskGroupSnap resource. This marks the DiskGroupSnap resource as OFFLINE.

## State definitions for DiskGroupSnap agent

ONLINE	The DiskGroupSnap resource functions normally.
OFFLINE	The DiskGroupSnap resource is not running.
UNKNOWN	A configuration error exists.
FAULTED	The DiskGroupSnap resource is taken offline unexpectedly outside of VCS control.

## Attributes for DiskGroupSnap agent

**Table 2-4** Required attributes

Required attribute	Description
TargetResName	<p>The name of the DiskGroup resource from the application service group.</p> <p>Type-dimension: string-scalar</p> <p>Example: "dgres"</p>
FDType	<p>Specifies the configuration to be used for the fire drill. The possible values for this attribute are:</p> <ul style="list-style-type: none"><li>■ Bronze</li><li>■ Gold (default)</li></ul> <p>The Bronze configuration uses the local host's VxVM site name as the site to be detached from the DiskGroup. This action leaves the DiskGroup vulnerable to site disaster since a copy of the production volume might not be available when the fire drill is in progress.</p> <p>In the Gold configuration there are at least three copies of the parent volume available on different sites, hence, even after detaching one site the volume is not vulnerable to site disaster while the fire drill is in progress.</p>

Table 2-5 Optional attributes

Optional attribute	Description
FDSiteName	<p>The unique VxVM site name tag for the fire drill disks. The value of this attribute is used in conjunction with the FDType attribute and it must be set to one of the sites registered in the main DiskGroup.</p> <ul style="list-style-type: none"> <li>When FDType is set to the Bronze configuration, the value of FDSiteName should either be empty or the name of the local host VxVM site for the fire drill host.</li> <li>When FDType is set to the Gold configuration, FDSiteName identifies a site in the DiskGroup to detach as a part of the fire drill. If FDSiteName is left blank, the agent will choose a site to detach based on the DiskGroup configuration. The agent chooses a site name from the DiskGroup which is neither the production server's site name nor the fire drill host's site name.</li> </ul> <p><a href="#">Table 2-6</a> shows the possible values of the attributes FDType and FDSiteName and the decision taken by the agent.</p>

Consider a configuration where the Production DiskGroup contains three sites: A, B, and C, and the Application service group is online on a node with local VxVM site ID is A. Fire drill is being done on another node Application service group is online on a node where local VxVM site ID is B.

Table 2-6 Example FDType configurations

FDType	Bronze			Gold/Empty		
FDSitename	Empty	B	C	Empty	B	C
Result	Use B as the site to detach and proceed	Detach site B from DiskGroup	Error	Check if there is another site other than A and B and select it. Else, it is an error	Error	Detach site C from the DiskGroup

## Notes for DiskGroupSnap agent

The DiskGroupSnap agent has the following notes:

- See [“Fire drill configuration after upgrading VCS”](#) on page 40.

- See “[Configuring the SystemZones attribute for the fire drill service group](#)” on page 40.
- See “[Configuring the FireDrill service group](#)” on page 40.
- See “[Adding the ReuseMntPt attribute to the ArgList attribute for the Mount agent type](#)” on page 41.
- See “[Configuration considerations](#)” on page 41.
- See “[Agent limitations](#)” on page 43.

## Fire drill configuration after upgrading VCS

After upgrading VCS from any earlier version to 6.0, delete all resources of type DiskGroupSnap and recreate them again using the new definitions of the attributes. Failure to perform this step might result in an unexpected behavior of the agent.

## Configuring the SystemZones attribute for the fire drill service group

You must assign the local system values to the SystemZones attribute of the application’s service group. You set these values so that the service group fails over in the same zone before it tries to fail over across zones.

For more information about campus cluster setup, refer to the *Veritas Cluster Server Administrator’s Guide*.

For example, you set up the service group’s SystemZones attribute for two zones: 0 and 1. You want the service group on Node\_A and Node\_B to fail over between the two nodes before it comes up on Node\_C and Node\_D. The application and its fire drill service group both have the following values for the SystemZones attribute:

```
SystemZones = { Node_A = 0, Node_B = 0, Node_C = 1, Node_D = 1 }
```

## Configuring the FireDrill service group

In the FireDrill service group, the application-level resources (for example, process resources, application resources, or Oracle resources, and so on) can have the same attribute values in the fire drill service group and the application service group. The reuse of the same values for the attributes can result in VCS reporting the wrong resources as online.

Set the FireDrill type-level attribute to 1 for those types. For example, if the Oracle and Listener resources are configured identically, set the FireDrill attribute for Oracle and Netlsnr to 1:



```
# haconf -makerw
# hatype -modify Oracle FireDrill 1
# hatype -modify Netlsnr FireDrill 1
# haconf -dump -makero
```

## Adding the ReuseMntPt attribute to the ArgList attribute for the Mount agent type

If you plan to use a Mount resource in a firedrill service group, you must add the ReuseMntPt attribute to ArgList and set its value to 1.

**To add the ReuseMntPt attribute to the ArgList attribute and set its value to 1**

- 1 Make the configuration read and write.

```
# haconf -makerw
```

- 2 Add the ReuseMntPt attribute to the ArgList attribute.

```
# hatype -modify Mount ArgList -add ReuseMntPt
```

- 3 Change the value of the ReuseMntPt attribute to 1 for the firedrill's Mount resource.

```
# hares -modify firedrill_mount_resource_name ReuseMntPt 1
```

- 4 Change the value of the ReuseMntPt attribute to 1 for the original Mount resource.

```
# hares -modify original_mount_resource_name ReuseMntPt 1
```

- 5 Make the configuration read only.

```
# haconf -dump -makero
```

## Configuration considerations

Keep the following recommendations in mind:

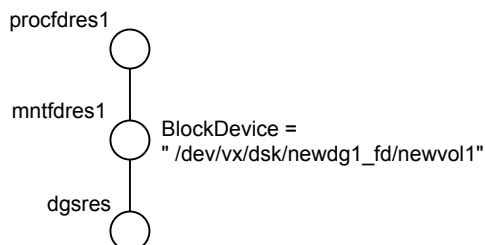
- You must install Veritas Volume Manager 5.1 or later with the FMR license and the Site Awareness license.
- Do not bring the DiskGroupSnap resource online in the SystemZone where the application service group is online.

- Make sure that the firedrill service group and the application service group both use the same values for the SystemZones attribute.
- Do not use Volume resources in the firedrill service group. The DiskGroupSnap agent internally uses the `vxvol` command to start all the volumes in the firedrill disk group.
- In large setups, you may need to tweak the various timer values so that the timers do not time out while waiting for VxVM commands to complete. The timers you need to tweak are the `OfflineTimeout` for the `DiskGroupSnap` resource and `MonitorInterval` and `ActionTimeout` for the associated `DiskGroup` resource, for example:

```
# haconf -makerw
# hares -override dgsres OfflineTimeout
# hares -modify dgsres OfflineTimeout 600
# hares -override dgres MonitorInterval
# hares -modify dgres MonitorInterval 1200 (this has to be twice
    the value intended for ActionTimeout below)
# hares -override dgres ActionTimeout
# hares -modify dgres ActionTimeout 600
# haconf -dump -makero
```

- When you create the firedrill service group, in general use the same attribute values that you use in the application service group. The `BlockDevice` attribute of the `Mount` resource changes between the application service group and the firedrill service group. In the `BlockDevice` path, you must append an `_fd` to the disk group name portion, for example, `/dev/vx/dsk/newdg1/newvol1` becomes `/dev/vx/dsk/newdg1_fd/newvol1`. See [Figure 2-3](#) on page 42, which shows the changes to resource values for the firedrill service group; note that the `Volume` resource is not included.
- Before commencing the fire drill, make sure that all the sites registered in the application `DiskGroup` are in `ACTIVE` state.

**Figure 2-3** Sample resource values for a `DiskGroupSnap` resource



## Agent limitations

The following limitations apply to the DiskGroupSnap agent:

- The DiskGroupSnap agent does not support Volume Sets.
- The DiskGroupSnap agent cannot be used in a Storage Foundation RAC environment.
- The online and offline operations of the DiskGroupSnap resource invokes VCS action entry points to run VxVM commands to detach/reattach the fire drill site. Since VxVM requires that these commands are run on the node where the disk group is imported, the disk group has to be imported on some node in the cluster before these operations.
- Take the firedrill service group offline before you shut down VCS on any node. If you fail to take the firedrill service group offline before you shut down VCS, you must manually reattach the fire drill site to the disk group to continue to perform fire drills.
- Use the enclosures that have the ASL/APM libraries that are supported in the Veritas Volume Manager. To view the supported enclosures, use the `vxddladm listsupport` command.
- Do not switch the Application service group when fire drill is in progress.

## Resource type definition for DiskGroupSnap agent

The resource type definition for this agent follows:

```
type DiskGroupSnap (  
  static int ActionTimeout = 120  
  static int MonitorInterval = 300  
  static int NumThreads = 1  
  static str ArgList[] = { TargetResName, FDSiteName, FDType }  
  str TargetResName  
  str FDSiteName  
  str FDType  
)
```

## Sample configurations for DiskGroupSnap agent

In [Figure 2-4](#), the Primary site is in the Bronze configuration and the Disaster recovery site is in a Gold configuration.

Since the Primary site does not have dedicated fire drill disks, it is in a Bronze configuration. In the Bronze configuration, you re-purpose the mirror disks in the disaster recovery site to serve as fire drill test disks. The drawback with the Bronze

configuration is that if a disk failure occurs when the fire drill is online at the Primary site, it results in a site failure.

The FDSiteName value in a bronze configuration is the VxVM site name. For this configuration, the FDSiteName attribute values for the nodes at the Primary site follow:

```
FDSiteName@Node_A = pri
FDSiteName@Node_B = pri
```

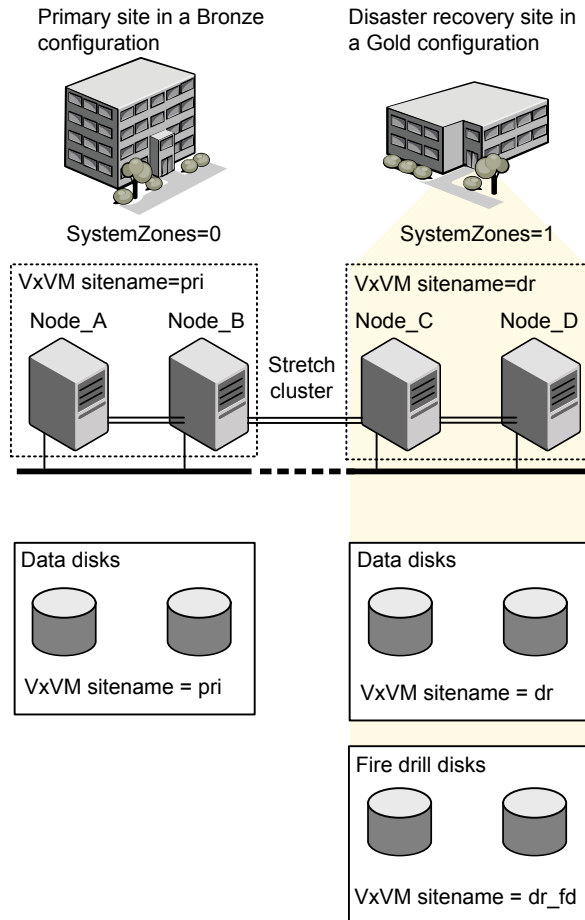
The Disaster Recovery site is in a Gold configuration as it has dedicated fire drill disks at the site. For the FDSiteName attribute, use the VxVM site tag given to the fire drill disks. For this configuration, the FDSiteName attribute values for the nodes at the Disaster recovery site follow:

```
FDSiteName@Node_C = dr_fd
FDSiteName@Node_D = dr_fd
```

Set values for the SystemZones attribute to zero for Node\_A and Node\_B, and one for Node\_C and Node\_D. For example:

```
SystemZones = { Node_A = 0, Node_B = 0, Node_C = 1, Node_D = 1 }
```

**Figure 2-4** Primary site with the Bronze configuration and the disaster recovery site with the Gold configuration



## Typical main.cf configuration for DiskGroupSnap agent

The following sample configuration shows the fire drill's service group and its corresponding application service group. The fire drill's service group follows:

```
group dgfdsg (
  SystemList = { Node_A = 0, Node_B = 1, Node_C = 2, Node_D = 3 }
  SystemZones = { Node_A = 0, Node_B = 0, Node_C = 1, Node_D = 1 }
)
```

```
DiskGroupSnap dgsres (
  TargetResName = dgres
)

FDtype = "Gold"
  FDSiteName @Node_A = pri
  FDSiteName @Node_B = pri
  FDSiteName @Node_C = dr_fd
  FDSiteName @Node_D = dr_fd
)

Mount mntfdres1 (
  MountPoint = "/dgsfs1"
  BlockDevice = "/dev/vx/dsk/newdgl_fd/newvol1"
  FSType = vxfs
  FsckOpt = "-y"
  ReuseMntPt = 1
)

Mount mntfdres2 (
  MountPoint = "/dgsfs2"
  BlockDevice = "/dev/vx/dsk/newdgl_fd/newvol2"
  FSType = vxfs
  FsckOpt = "-y"
  ReuseMntPt = 1
)

Process procfres1 (
  PathName = "/usr/bin/ksh"
  Arguments = "/scrib.sh /dgsfs1"
)

Process procfres2 (
  PathName = "/usr/bin/ksh"
  Arguments = "/scrib.sh /dgsfs2"
)

requires group dgsg offline local

mntfdres1 requires dgsres
mntfdres2 requires dgsres
```

```
procfres1 requires mntfdres1
procfres2 requires mntfdres2
```

The application's service group (the actual service group) follows:

```
group dgsg (
    SystemList = { Node_A = 0, Node_B = 1, Node_C = 2, Node_D = 3 }
    SystemZones = { Node_A = 0, Node_B = 0, Node_C = 1, Node_D = 1 }
)

DiskGroup dgres (
    DiskGroup = newdgl
)

Mount mntres1 (
    MountPoint = "/dgsfs1"
    BlockDevice = "/dev/vx/dsk/newdgl/newvol1"
    FSType = vxfs
    FsckOpt = "-y"
    ReuseMntPt = 1
)

Mount mntres2 (
    MountPoint = "/dgsfs2"
    BlockDevice = "/dev/vx/dsk/newdgl/newvol2"
    FSType = vxfs
    FsckOpt = "-y"
    ReuseMntPt = 1
)

Process procrs1 (
    PathName = "/usr/bin/ksh"
    Arguments = "/scrib.sh /dgsfs1"
)

Process procrs2 (
    PathName = "/usr/bin/ksh"
    Arguments = "/scrib.sh /dgsfs2"
)

mntres1 requires dgres
mntres2 requires dgres
```

```
procrs1 requires mntres1
procrs2 requires mntres2
```

## Sample main.cf of DiskGroupSnap with Oracle resource

The following Oracle configuration has been simplified for presentation within this guide.

```
group fd_oragrp (
    SystemList = { Node_A = 0, Node_B = 1 }
    AutoStart = 0
    SystemZones = { Node_A = 0, Node_B = 1 }
)

DiskGroupSnap dgres (
    FDSiteName @Node_A = siteA
    FDSiteName @Node_B = siteB
    TargetResName = oradg_res
    FDType = "Bronze"
)

IP fd_oraip (
    Device = bge0
    Address = "10.198.95.191"
    NetMask = "255.255.255.0"
)

Mount fd_archmnt (
    FsckOpt = "-y"
    ReuseMntPt = 1
    BlockDevice = "/dev/vx/dsk/oradg_fd/archive_vol"
    MountPoint = "/ora_archive"
    FSType = vxfs
)

Mount fd_datamnt (
    FsckOpt = "-y"
    ReuseMntPt = 1
    BlockDevice = "/dev/vx/dsk/oradg_fd/data_vol"
    MountPoint = "/ora_data"
    FSType = vxfs
)

NIC fd_oranic (
```



```
        Device = bge0
NetworkHosts = { "10.198.95.1" }
    )

Netlsnr fd_LSNR (
    Home = "/opt/oracle/ora_home"
    Owner = oracle
    )

Oracle fd_Ora_01 (
    Owner = oracle
    Home = "/opt/oracle/ora_home"
    Sid = Ora_01
    )

requires group oragrp offline local
fd_LSNR requires fd_Ora_01
fd_LSNR requires fd_oraip
fd_Ora_01 requires fd_archmnt
fd_Ora_01 requires fd_datamnt
fd_archmnt requires dgres
fd_datamnt requires dgres
fd_oraip requires fd_oranic

group oragrp (
    SystemList = { Node_A = 0, Node_B = 1 }
    AutoStartList = { Node_A, Node_B }
    SystemZones = { Node_A = 0, Node_B = 1 }
    )

DiskGroup oradg_res (
    DiskGroup = oradg
    )

IP Node_A4vip (
    Device = bge0
    Address = "10.198.95.192"
    Netmask = "255.255.252.0"
    )

Mount arch_mnt (
    FsckOpt = "-y"
    ReuseMntPt = 1
    BlockDevice = "/dev/vx/dsk/oradg/archive_vol"
```

```
MountPoint = "/ora_archive"
FSType = vxfs
)

Mount data_mnt (
  FsckOpt = "-y"
  ReuseMntPt = 1
  BlockDevice = "/dev/vx/dsk/oradg/data_vol"
  MountPoint = "/ora_data"
  FSType = vxfs
)

NIC nic_Node_A4vip (
  Device = bge0
)

Netlsnr LSNR (
  Home = "/opt/oracle/ora_home"
  Owner = oracle
)

Oracle Ora_01 (
  Owner = oracle
  Home = "/opt/oracle/ora_home"
  Sid = Ora_01
)

Volume arch_vol (
  Volume = archive_vol
  DiskGroup = oradg
)

Volume data_vol (
  Volume = data_vol
  DiskGroup = oradg
)

LSNR requires Ora_01
LSNR requires Node_A4vip
Ora_01 requires arch_mnt
Ora_01 requires data_mnt
arch_mnt requires arch_vol
arch_vol requires oradg_res
data_mnt requires data_vol
```

```
data_vol requires oradg_res
Node_A4vip requires nic_Node_A4vip
```

## Debug log levels for DiskGroupSnap agent

The DiskGroupSnap agent uses the following debug log levels:

DBG\_1

## Disk agent

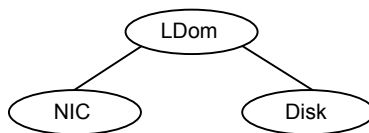
Monitors a physical disk or a partition.

You can use the Disk agent to monitor a physical disk or a slice that is exported to LDom.

## Dependencies

Disk resources have no dependencies.

**Figure 2-5** Sample service group that includes a Disk resource on Solaris



## Agent functions

Monitor	Performs read I/O operations on the raw device to determine if a physical disk or a partition is accessible.
---------	--

## State definitions

The state definitions for this agent follow:

ONLINE	Indicates that the disk is working normally.
FAULTED	Indicates that the disk has stopped working or is inaccessible.
UNKNOWN	Indicates that a problem exists either with the configuration or the ability to determine the status of the resource.

## Attributes

**Table 2-7** Required attributes

Required attribute	Description
Partition	<p>Indicates which partition to monitor. Specify the partition with the full path beginning with a slash (/).</p> <p>If absolute path is not specified, the name is assumed to reside in /dev/rdisk/.</p> <p>Example: "/dev/rdisk/c2t0d0s2" or "/dev/vx/dmp/c2t0d0s2"</p> <p>Type and dimension: string-scalar</p> <p><b>Note:</b> If Veritas DMP device name is provided, ensure that persistence of the naming scheme is set to Yes to avoid path name changes by reboot or device re-configuration. Please see <i>Veritas Dynamic Multi-Pathing Administrator's guide</i> for details on setting persistence for naming scheme.</p>

## Resource type definition

The resource definition for this agent on Solaris follows:

```
type Disk (
    static int OfflineMonitorInterval = 60
    static str ArgList[] = { Partition }
    static str Operations = None
    str Partition
)
```

## Debug log levels

The Disk agent uses the following debug log levels:

DBG\_1

## Volume agent

The Volume agent brings online, takes offline, and monitors a Veritas Volume Manager (VxVM) volume. Use the agent to make a volume highly available.

---

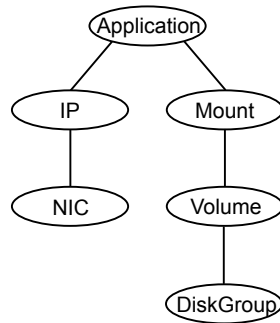
**Note:** Do not use the Volume agent for volumes created for replication.

---

## Dependencies for Volume agent

Volume resources depend on DiskGroup resources.

**Figure 2-6** Sample service group that includes a Volume resource



## Agent functions for Volume agent

Online	Uses the <code>vxrecover</code> command to start the volume.
Offline	Uses the <code>vxvol</code> command to stop the volume.
Monitor	Attempts to read a block from the raw device interface to the volume to determine if the volume is online, offline, or unknown.
Clean	Terminates all ongoing resource actions and takes the resource offline—forcibly when necessary.

## State definitions for Volume agent

ONLINE	Indicates that the specified volume is started and that I/O is permitted.
OFFLINE	Indicates that the specified volume is not started and that I/O is not permitted.
FAULTED	Indicates the volume stopped unexpectedly and that I/O is not permitted.
UNKNOWN	Indicates that the agent could not determine the state of the resource or that the resource attributes are configured incorrectly.

## Attributes for Volume agent

**Table 2-8** Required attributes

Required attribute	Description
DiskGroup	Name of the disk group that contains the volume. Type and dimension: string-scalar Example: "DG1"
Volume	Name of the volume from disk group specified in DiskGroup attribute. Type and dimension: string-scalar Example: "DG1Vol1"

**Table 2-9** Internal attribute

Optional attribute	Description
NumThreads	Number of threads used within the agent process for managing resources. This number does not include threads used for other internal purposes.  Do not modify this attribute for this agent.  Setting this attribute to a higher value may result in agent function timeouts due to serialization of underlying commands.  Default: 1

## Resource type definition for Volume agent

The resource type definition for this agent follows:

```
type Volume (
    static int NumThreads = 1
    static str ArgList[] = { Volume, DiskGroup }
    str Volume
    str DiskGroup
)
```

## Sample configuration for Volume agent

The sample configuration for the Volume agent follows:

```

Volume sharedg_vol3 (
    Volume = vol3
    DiskGroup = sharedg
)

```

## Debug log levels for Volume agent

The Volume agent uses the following debug log levels:

DBG\_1

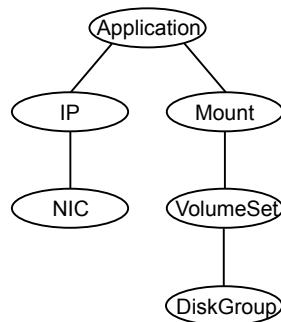
## VolumeSet agent

The VolumeSet agent brings online, takes offline, and monitors a Veritas Volume Manager (VxVM) volume set. Use the agent to make a volume set highly available.

## Dependencies for VolumeSet agent

VolumeSet resources depend on DiskGroup resources.

**Figure 2-7** Sample service group that includes a VolumeSet resource



## Agent functions for VolumeSet agent

Online	Uses the vxrecover command to start the volume set.
Offline	Uses the vxvset command to stop the volume set.
Monitor	Attempts to read a block from the raw device interface to the volumes inside the volume set to determine if the volume set is online, offline, or unknown.

Clean Terminates all ongoing resource actions and takes the resource offline—forcibly when necessary.

## State definitions for VolumeSet agent

ONLINE Indicates that all the volumes in the volume set are started and that I/O is permitted for all the volumes.

OFFLINE Indicates that at least one of the volume is not started in the volume set and that I/O is not permitted for that volume.

FAULTED Indicates the volumes that are inside the volume set have stopped unexpectedly and that I/O is not permitted.

UNKNOWN Indicates that the agent could not determine the state of the resource or that the resource attributes are configured incorrectly.

## Attributes for VolumeSet agent

**Table 2-10** Required attributes

Required attribute	Description
DiskGroup	The name of the disk group that contains the volume set. Type and dimension: string-scalar Example: "DG1"
VolumeSet	The name of the volume set from the disk group that you specified in the DiskGroup attribute. Type and dimension: string-scalar Example: "DG1VolSet1"

## Resource type definition for VolumeSet agent

```
type VolumeSet (
    static str ArgList[] = { DiskGroup, VolumeSet }
    str VolumeSet
    str DiskGroup
)
```



## Sample configurations for VolumeSet agent

This sections contains sample configurations for this agent.

### A configured VolumeSet that is dependent on a DiskGroup resource

The VolumeSet's shared\_vset3 resource is configured and is dependent on DiskGroup resource with a shared diskgroup.

```
VolumeSet sharedg_vset3 (  
  VolumeSet = vset3  
  DiskGroup = sharedg  
)
```

## Agent notes for VolumeSet agent

This sections contains notes about this agent.

## Inaccessible volumes prevent the VolumeSet agent from coming online

The VolumeSet agent does not come online if any volume is inaccessible in its volume set.

### To remove a volume from volume set

- ◆ Enter the following commands to remove a volume from a volume set mounted on mountpoint.

```
# fsvoladm remove mountpoint volume_name  
# vxvset -g diskgroup rmvol volumeset volume_name
```

## Debug log levels for VolumeSet agent

The VolumeSet agent uses the following debug log levels:

DBG\_1, DBG\_4

## Mount agent

The Mount agent brings online, takes offline, and monitors a file system or an NFS client mount point. You can use the agent to make file systems or NFS client mount points highly available.

This agent is zone-aware.

This agent is IMF-aware and uses asynchronous monitoring framework (AMF) kernel driver for IMF notification. For more information about the Intelligent Monitoring Framework (IMF) and intelligent resource monitoring, refer to the Veritas Cluster Server Administrator's Guide.

---

**Note:** Intelligent Monitoring Framework for mounts is supported only for the following mount types: VxFS and NFS.

---

This agent also supports high availability fire drills.

The ContainerName and ContainerType attributes are deprecated.

Refer to the *Storage Foundation High Availability Virtualization Guide* for information on using mount resources inside local zone.

For mounting the NFS file system, the Mount agent supports the IPv6 protocol.

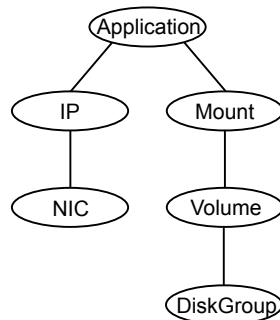
For important information about this agent, See "[Notes for Mount agent](#)" on page 67.

## Dependencies for Mount agent

The Mount resource does not depend on any other resources.

In some scenarios, the Mount agent depends on Volume or DiskGroup resources.

**Figure 2-8** Sample service group that includes a Mount resource



## Agent functions for Mount agent

Online	<p>Mounts a block device on the directory. If the mount process fails for non-NFS mounts, the agent attempts to run the fsck command on the device before attempting to mount the file system again.</p> <p>If file system type is NFS, agent mounts the remote file system to a specified directory. The remote NFS file system is specified in the BlockDevice attribute.</p>
Offline	Unmounts the mounted file system.
Monitor	<p>Determines if the file system is mounted.</p> <p>If IMF is enabled for the Mount agent, the resource is monitored asynchronously and any change in the resource state is immediately sent to VCS for appropriate action.</p>
imf_init	Initializes the agent to interface with the asynchronous monitoring framework (AMF) kernel driver. This function runs when the agent starts up.
imf_getnotification	Waits for notification about resource state changes. This function runs after the agent initializes with the AMF kernel driver. The agent continuously waits for notification and takes action on the resource upon notification.
imf_register	Registers the resource entities, which the agent must monitor, with the AMF kernel driver. This function runs for each resource after the resource goes into steady state (online or offline). This action entry point registers the mount point, block device, and file system type for mount agent.
Clean	Unmounts the mounted file system forcefully.

## Info

The Mount agent info function executes the command:

```
# df -k mount_point
```

The output displays Mount resource information:

```
Size Used Avail Use%
```

To initiate the info agent function, set the InfoInterval timing to a value greater than 0. In this example, the info agent function executes every 60 seconds:

```
# haconf -makerw
```

```
# hatype -modify Mount InfoInterval 60
```

The command to retrieve information about the Mount resource is:

```
# hares -value mountres ResourceInfo
```

Output includes:

```
Size 2097152  
Used 139484  
Available 1835332  
Used% 8%
```

## Action

- **chgmtlock**  
Resets the VxFS file system lock to a VCS-defined lock.
- **mountpoint.vfd**  
Checks if the specified mount point exists on the offline node. If it fails and you request that VCS fixes it, it creates the mount point directory using `mkdir` command.
- **mounted.vfd**  
Checks if the mount point is already mounted on the offline node. If it fails, you need to unmount all the file systems from the specified mount point directory.
- **vxfslc.vfd**  
Checks for valid Veritas File System (VxFS) licenses. If it fails, you need to update the license for VxFS.
- **mountentry.vfd**  
Checks that the mount point is not listed in auto file system tables. For example,  
`/etc/vfstab`  
If this action fails, you need to remove the mount point from auto file system tables.

## State definitions for Mount agent

The state definitions for this agent follow:

ONLINE	<p>For the local file system, indicates that the block device is mounted on the specified mount point.</p> <p>For an NFS client, indicates that the NFS remote file system is mounted on the specified mount directory.</p>
OFFLINE	<p>For the local file system, indicates that the block device is not mounted on the specified mount point.</p> <p>For an NFS client, indicates that the NFS remote file system is not mounted on the specified mount directory.</p>
FAULTED	<p>For the local file system, indicates that the block device has unexpectedly unmounted.</p> <p>For the NFS client, indicates that the NFS remote file system has unexpectedly unmounted.</p>
UNKNOWN	<p>Indicates that a problem exists either with the configuration or the ability to determine the status of the resource.</p>

## Attributes for Mount agent

**Table 2-11** Required attributes

Required attribute	Description
BlockDevice	<p>Block device for mount point.</p> <p>When you specify the block device to mount, enclose IPv6 addresses in square brackets. The mount command requires square brackets around the IPv6 address to differentiate between the colons in the address and the colon that separates the remote host and remote directory.</p> <p>Type and dimension: string-scalar</p> <p>Examples:</p> <ul style="list-style-type: none"> <li>■ "/dev/vx/dsk/myvcs_dg/myvol"</li> <li>■ IPv4</li> <li>■ "10.209.70.90:/dirname/anotherdir"</li> <li>■ IPv6</li> <li>■ "[fe80::1:2:3]:/dirname/anotherdir"</li> </ul>

**Table 2-11** Required attributes (*continued*)

Required attribute	Description
FckOpt	<p>Mandatory for the following file system types:</p> <ul style="list-style-type: none"><li>■ ufs</li><li>■ vxfs</li></ul> <p>Use this attribute to specify options for the <code>fck</code> command. You must correctly set this attribute for local mounts. If the mount process fails, the <code>fck</code> command is executed with the specified options before it attempts to remount the block device. Its value must include either <code>-y</code> or <code>-n</code>. Refer to the <code>fck</code> manual page for more information.</p> <p>For NFS mounts, the value of this attribute is not applicable and is ignored.</p> <p>Type and dimension: string-scalar</p> <p>VxFS example: <code>-y</code></p> <p><b>Note:</b> When you use the command line, add the <code>%</code> sign to escape <code>'</code>. For example: <code>hares -modify MntRes FckOpt %-y</code></p>
FSType	<p>Type of file system.</p> <p>Supports <code>ufs</code>, <code>nfs</code>, <code>zfs</code>, <code>lofs</code>, or <code>vxfs</code>.</p> <p>Type and dimension: string-scalar</p> <p>Example: <code>"vxfs"</code></p>
MountPoint	<p>Directory for mount point</p> <p>Type and dimension: string-scalar</p> <p>Example: <code>"/tmp/mnt"</code></p>

Table 2-11 Required attributes (*continued*)

Required attribute	Description
VxFSMountLock	<p>This attribute is only applicable to Veritas (VxFS) file systems. This attribute controls a file system locking feature to prevent accidental unmounts.</p> <p>This attribute can take three values: 0, 1, or 2.</p> <p>VxFSMountLock=0</p> <p>The resource does not detect any changes to the lock when VCS reports that it is online after you set the value to zero.</p> <ul style="list-style-type: none"> <li>■ If the mount point is initially locked with the mntlock="VCS", the monitor agent function unlocks it.</li> <li>■ If the mount point is initially locked with a key that is not equal to "VCS", the agent logs a message once.</li> <li>■ If the mount point is initially not locked, no action is performed.</li> </ul> <p>VxFSMountLock=1</p> <p>The resource does not detect changes to the lock when VCS reports it online after the value was set to one. VCS does not monitor the lock.</p> <ul style="list-style-type: none"> <li>■ If the mount point is initially locked with the mntlock="VCS", no action is performed.</li> <li>■ If the mount point is initially locked with a key that is not equal to "VCS", the agent logs a message once.</li> <li>■ If the mount point is initially not locked, the monitor agent function locks it with the mntlock="VCS".</li> </ul> <p>VxFSMountLock=2</p> <p>When the value of the VxFSMountLock is 2, the file system is locked and the agent monitors any change to mntlock.</p> <ul style="list-style-type: none"> <li>■ If the mount point is locked with the mntlock="VCS", no action is performed.</li> <li>■ If the mount point is initially locked with a key that is not equal to "VCS", the monitor agent function logs a message whenever a change in mntlock is detected.</li> <li>■ If the mount point is not locked, the agent locks it with the mntlock="VCS".</li> </ul> <p>Type and dimension: integer-scalar</p> <p>Default: 1</p>

Table 2-12 Optional attributes

Optional attribute	Description
MountOpt	<p>Options for the <code>mount</code> command. Refer to the <code>mount</code> manual page for more information.</p> <p>Do not set the VxFS mount option "<code>mntlock=key</code>". The agent uses this option only when bringing a Mount resource online.</p> <p>Type and dimension: string-scalar</p> <p>Example: "<code>rw</code>"</p>
SnapUmount	<p>If the value of this attribute is 1, this attribute automatically unmounts VxFS snapshots when the file system is unmounted.</p> <p>If the value of this attribute is 0, and snapshots are mounted, the resource cannot be brought offline. In this case, failover does not occur.</p> <p>Type and dimension: integer-scalar</p> <p>Default: 0</p>
CkptUmount	<p>If the value of this attribute is 1, this attribute automatically unmounts VxFS Storage Checkpoints when file system is unmounted.</p> <p>If the value of this attribute is 0, and Storage Checkpoints are mounted, then failover does not occur.</p> <p>Type and dimension: integer-scalar</p> <p>Default: 1</p>
AccessPermissionChk	<p>If the value of this attribute is 1 or 2, the monitor verifies that the values of the <code>MntPtPermission</code>, <code>MntPtOwner</code>, and <code>MntPtGroup</code> attributes are the same as the actual mounted file system values.</p> <p>If any of these do not match the values that you have defined, a message is logged.</p> <p>If the value of this attribute is 2, and if the mounted file system permissions do not match the attribute values, the Monitor agent function returns the state as OFFLINE.</p> <p>Type and dimension: integer-scalar</p> <p>Default: 0</p>



Table 2-12 Optional attributes (*continued*)

Optional attribute	Description
CreateMntPt	<p>If the value of this attribute is 0, no mount point is created. The mount can fail if the mount point does not exist with suitable permissions.</p> <p>If the value of this attribute is 1 or 2, and a mount point does not exist, the agent creates a mount point with system default permissions when the resource is brought online. If the permissions for the mount point are less than 555, a warning message is logged.</p> <p>If the value of this attribute is 2, and the mount point does not exist, the agent creates a mount point with system default permissions when the resource is brought online. If the permissions for the mount point are less than 555, a warning message is logged. In addition, VCS deletes the mount point and any recursively created directories when the resource is brought offline. The mount point gets deleted only if it is empty, which is also true for recursive mount points.</p> <p>Type and dimension: integer-scalar</p> <p>Default: 0</p>
MntPtGroup	<p>This attribute specifies the group ownership of the mounted file system. The agent verifies the group ownership of the mounted file system every monitor cycle if the value of the AccessPermissionChk attribute is not 0.</p> <p>Type and dimension: string-scalar</p> <p>Example: "grp1"</p>
MntPtOwner	<p>This attribute specifies the user ownership of the mounted file system. The agent verifies the user ownership of the mounted file system every monitor cycle if the value of the AccessPermissionChk attribute is not 0.</p> <p>Type and dimension: string-scalar</p> <p>Example: "usr1"</p>
MntPtPermission	<p>This attribute specifies the permissions of the mounted file system in an absolute format of a four-digit octal. The agent verifies the mode of the mounted file system every monitor cycle if the value of the AccessPermissionChk attribute is not 0.</p> <p>Type and dimension: string-scalar</p> <p>Example: "0755"</p>

Table 2-12 Optional attributes (*continued*)

Optional attribute	Description
OptCheck	<p>The value of this attribute determines if VCS should verify the mount options. The state of the resource is determined based on the result of the verification.</p> <p>If the value of this attribute is 0 (default), the mount options are not checked.</p> <p>If the value of the OptCheck attribute is 1, 2 or 3, a check is performed to see if the mount command options that you have specified for VCS are set in the MountOpt attribute. The MountOpt attributes should be the same as the actual mount command options. If the actual mount options differ from the MountOpt attribute, a message is logged. The state of the resource depends on the value of this attribute.</p> <p>If the value of the attribute is 1, the state of the resource is unaffected.</p> <p>If the value is 2, the state of the resource is set to offline.</p> <p>If the value is 3, state of the resource is set to unknown.</p> <p>Type and dimension: integer-scalar</p> <p>Default: 0</p>
RecursiveMnt	<p>If the value of this attribute is 1, VCS creates all the parent directories of the mount point if necessary. All directories in the path are created with system default permissions.</p> <p><b>Note:</b> Permissions on mount points must be a minimum of 555 for the operating system commands to work correctly.</p> <p>Type and dimension: boolean-scalar</p> <p>Default: 0</p>
ReuseMntPt	<p>If the same mount point needs to be specified in more than one mount resource, set the value of this attribute to 1. Note that this attribute only accepts a value of 1 or 0.</p> <p>To use this attribute, the cluster administrator needs to add this attribute to the arglist of the agent. Set the appropriate group and resource dependencies such that only one resource can come online on a system at a time.</p> <p>Type and dimension: integer-scalar</p> <p>Default: 0</p>

## Resource type definition for Mount agent

The resource definition for this agent on Solaris follows:

```
type Mount (  
    static keylist SupportedActions = { "mountpoint.vfd",  
    "mounted.vfd", "vxfslic.vfd", "chgmtlock", "mountentry.vfd" }  
    static str ArgList[] = { MountPoint, BlockDevice, FSType,  
    MountOpt, FsckOpt, SnapUmount, CkptUmount, OptCheck,  
    CreateMntPt, MntPtPermission, MntPtOwner, MntPtGroup,  
    AccessPermissionChk, RecursiveMnt, VxFSMountLock }  
    static int IMF{} = { Mode = 3, MonitorFreq = 1,  
    RegisterRetryLimit = 3 }  
    static str IMFRegList[] = { MountPoint, BlockDevice, FSType }  
    static boolean AEPTIMEOUT = 1  
    str MountPoint  
    str BlockDevice  
    str FSType  
    str MountOpt  
    str FsckOpt  
    int SnapUmount  
    int CkptUmount = 1  
    int OptCheck = 0  
    int CreateMntPt = 0  
    int ReuseMntPt = 0  
    str MntPtPermission  
    str MntPtOwner  
    str MntPtGroup  
    int AccessPermissionChk = 0  
    boolean RecursiveMnt = 0  
    int VxFSMountLock = 1  
)
```

## Notes for Mount agent

The Mount agent has the following notes:

- [High availability fire drill](#)
- [VxFS file system lock](#)
- [IMF usage notes](#)
- [IPv6 usage notes](#)

- [Support for loopback file system](#)
- [ZFS file system and pool creation example](#)
- [Enabling Level two monitoring for the Mount agent](#)

## High availability fire drill

The high availability fire drill detects discrepancies between the VCS configuration and the underlying infrastructure on a node; discrepancies that might prevent a service group from going online on a specific node.

For Mount resources, the high availability drill performs the following, it:

- Checks if the specified mount point directory exists
- Checks if the mount point directory is already used
- Checks for valid Veritas (VxFS) file system licenses
- Checks if the mount point exists in the `/etc/vfstab` file

For more information about using the high availability fire drill, see the *Veritas Cluster Server Administrator's Guide*.

## VxFS file system lock

If the mount option in the mount table output has the option `mntlock="key"`, then it is locked with the key "key". To verify if mount locking is in use and has the value of "key", run the `mount` command and review its output.

```
# mount
```

If the VxFS file system has `mntlock="key"` in its mount options, then unmounting the file system fails.

You can unlock the file system with the `fsadm` command and then unmount it. To unlock a locked mount, run the following command where "key" is the lock identifier and `mount_point_name` is the file system mount point.

```
# /opt/VRTS/bin/fsadm -o mntunlock="key" mount_point_name
```

To unmount a file system mounted with locking, run the `vxumount` command with the option `mntunlock="key"`, for example:

```
# /opt/VRTS/bin/umount -o mntunlock="key" mount_point_name
```

## IMF usage notes

If you use IMF for intelligent resource monitoring, review the following recommendations. Depending on the value of the FSType attribute, you must set the MonitorFreq key value of the IMF attribute as follows:

- FSType attribute value is vxfs:
  - For VxFS version 5.1 SP1 or later:

You can either set the MonitorFreq to 0 or a high value. Setting the value of the MonitorFreq key to a high value will ensure that the agent does not run the monitor function frequently. Setting the MonitorFreq key to 0 will disable the traditional monitoring while IMF monitoring is in progress. Traditional monitoring will be done only after receiving the notification for a resource. However, if the value of the AccessPermissionChk attribute is set to 1, then set the MonitorFreq key value to the frequency at which you want the agent to run the monitor function.
  - For VxFS version 5.1 or earlier:

With VxFS versions prior to 5.1 SP1, VCS IMF only monitors file systems getting mounted and unmounted. To monitor other events, you must enable poll-based monitoring. Set the MonitorFreq key value to the frequency at which you want the agent to run the monitor function.

See the *Veritas Cluster Server Administrator's Guide* for the IMF attribute description.

## IPv6 usage notes

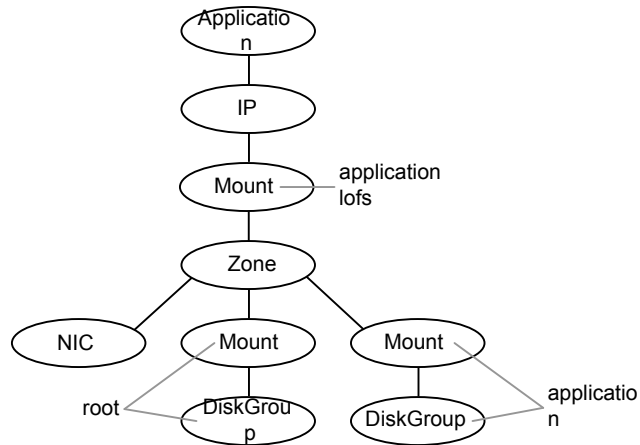
Review the following information for IPv6 use:

- For IPv6 functionality for NFS, you must use NFS version 4 in order to make the mount reachable. Note that NFSv4 requires several configuration steps in the operating system and NFS-related resources in VCS to enable it on the client and the exporting server.

## Support for loopback file system

The Mount agent provides loopback file system support. You can manage the loopback file system as a Mount resource. You can use this loopback support to mount a file system in the global zone and share it in non-global zones. For loopback support, configure the FSType attribute to use a value of lofs.

**Figure 2-9** Sample service group for for the zone root on shared storage with a loopback file system when VCS manages the loopback file system as a Mount resource



The following is a sample configuration where you use the Mount resource to manage the lofs file system:

```

group loopbacksg (
    SystemList = { sysA = 0, sysB = 1 }
    ContainerInfo@sysA = { Name = zone1, Type = Zone, Enabled = 1 }
    ContainerInfo@sysB = { Name = zone1, Type = Zone, Enabled = 1 }
)
Mount lofs_mnt_global_to_local (
    MountPoint = "/export/home/zone1/root/lofs_mnt"
    BlockDevice = "/mnt1/m1"
    FSType = lofs
)
Zone z1 (
    Mount base_mnt (
        MountPoint = "/mnt1"
        BlockDevice = "/dev/vx/dsk/tdg/tv011"
        FSType = vxfs
        FsckOpt = "-y"
    )
    lofs_mnt_global_to_local requires z1
    lofs_mnt_global_to_local requires base_mnt
)

```

## Enabling Level two monitoring for the Mount agent

Level two monitoring can be enabled for the Mount agent only if FSType is set to "nfs".

To enable Level two monitoring, run the following commands:

- # haconf -makerw
- # hares -override resource\_name LevelTwoMonitorFreq
- # hares -modify resource\_name LevelTwoMonitorFreq 1
- # haconf -dump -makero

For more details about the LevelTwoMonitorFreq attribute, refer to the *Veritas Cluster Server Agent Developer's Guide*.

## ZFS file system and pool creation example

If you want to use the Mount resource to monitor the ZFS file system, perform the following steps.

Create the tank storage pool and file system on the disk device c1t0d0 for example.

```
# zpool create tank c1t0d0
```

Create the home file system in tank.

```
# zfs create tank/home
```

Set the value of the MountPoint attribute to legacy.

```
# zfs set mountpoint=legacy tank/home
```

Set the Mount agent's attributes. The following is an example of this configuration's main.cf file.

```
Mount m1 (  
    MountPoint = "/mp1"  
    BlockDevice = "tank/home"  
    FSType = zfs  
    MountOpt = rw  
    FsckOpt = "-n"  
)
```

## Sample configurations for Mount agent

### VxFS configuration example for Mount agent

Configuration for VxFS follows:

```
Mount mnt-fs1 (
  MountPoint= "/mnt1"
  BlockDevice = "/dev/vx/dsk/mnt-dg1/mnt-voll"
  FSType = "vxfs"
  FscckOpt = "-n"
  MountOpt = "rw"
)
```

## Debug log levels for Mount agent

The Mount agent uses the following debug log levels:

DBG\_1, DBG\_2, DBG\_3, DBG\_4, DBG\_5

## Zpool agent

The Zpool agent brings online, takes offline, and monitors ZFS storage pools. It exports ZFS storage pools (which reside on shared storage) from one node. It then imports the pool onto another node as required.

ZFS's automount feature mounts all its file systems by setting the mountpoint property to something other than legacy. To find the value of the mountpoint property, use the `zfs get` command. For example, from the command line for the tank mountpoint, enter:

```
# zfs get mountpoint tank
NAME          PROPERTY      VALUE          SOURCE
tank          mountpoint    /tank          default
```

As another example, to find the value of the mountpoint property for the legacypool storage pool, enter:

```
# zfs get mountpoint legacypool
NAME          PROPERTY      VALUE          SOURCE
tank          mountpoint    legacy         default
```

The Zpool agent checks this property, and checks the `ChkZFSMounts` attribute to decide whether the mounted file system should be checked in the Zpool agent or not.



If the value of the mountpoint property is something other than legacy, the agent checks the mount status of the ZFS file systems.

If the value of the mountpoint property is legacy, then it does not check the file system mount status. The agent assumes that you plan to use Mount resources to manage and monitor the ZFS file systems.

See [“VCS support for multi-pathing solutions”](#) on page 22.

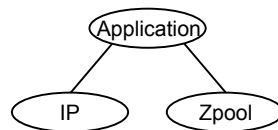
## Limitations for Zpool agent

The agent does not support the use of logical volumes in ZFS. If ZFS logical volumes are in use in the pool, the pool cannot be exported, even with the `-f` option. Oracle does not recommend the use of logical volumes in ZFS due to performance and reliability issues.

## Dependencies for Zpool agent

No dependencies exist for the Zpool resource for a pool that has a non-legacy value for its mountpoint property.

**Figure 2-10** Sample service group for a Zpool resource



## Agent functions for Zpool agent

Online	Imports the ZFS storage pool.
Offline	Exports the ZFS storage pool.

Monitor	<p>Check the online status of the ZFS pool.</p> <p>If the mountpoint property of the ZFS file system is set and its value is not legacy, and the attribute ChkZFSMounts is enabled, then the agent checks if all the ZFS file systems under the same ZFS storage pool are mounted.</p> <p>If the ZFS pool contains a ZFS file system that a non-global zone uses, then you need to import the pool before the zone boots up. After the zone boots up, if the mountpoint property for this ZFS file system that the non-global zone uses is not set to legacy, the file system is mounted after the zone boots up.</p> <p>If you have enabled the ChkZFSMounts attribute in the Zpool resource, the Monitor function skips checking the availability of the ZFS file system because unless the zone resource is up, the file systems are not mounted.</p> <p>The Zone resource depends on the Zpool resource for the non-global zone scenario. In this case, you need to provide the ZoneResName attribute, which indicates the name of the Zone resource. When the Zone resource is in an ONLINE state, then ChkZFSMounts starts to check the mount status of the ZFS file system pool that the non-global zone uses.</p>
Clean	<p>Exports the ZFS storage pool forcefully.</p>

## State definitions for Zpool agent

ONLINE	<p>Reports an ONLINE state when the ZFS file systems that share a common storage pool are mounted, and the <code>zpool list -H -o health \$Poolname</code> indicates that the pool is online.</p>
OFFLINE	<p>Reports an OFFLINE state when all of the ZFS file systems that share a common storage pool are unmounted. It also reports an OFFLINE state when the <code>zpool list -H -o health \$Poolname</code> command's status indicates that the pool is offline.</p>
UNKNOWN	<p>Reports an UNKNOWN state in the following situations:</p> <ul style="list-style-type: none"><li>■ If the status of the storage pool is unavailable.</li><li>■ If the storage pool is online but the path of the mounted file system does not match the path that is specified in the AltRootPath attribute of this agent.</li><li>■ If the storage pool is online but <code>alrootpath</code> setting of the pool is not set.</li></ul>

## Attributes for Zpool agent

**Table 2-13** Required attributes

Required attribute	Description
PoolName	<p>The name of the ZFS storage pool name.</p> <p>Type and dimension: string-scalar</p> <p>Default: n/a</p> <p>Example: tank</p>
AltRootPath	<p>Provides the alternate root path that is necessary to prevent the <code>etc/zfs/zpool.cache</code> file from being populated.</p> <p>Supplying this value keeps a node from importing the ZFS storage pool automatically when it restarts after a crash. Not importing the ZFS storage prevents concurrency violations and file system corruption.</p> <p>If you do not provide a value for the <code>AltRootPath</code> attribute, VCS sets the <code>\$AltRootPath</code> to <code>"/"</code> as a workaround. This workaround makes sure that the ZFS command <code>zpool import -R \$AltRootPath \$PoolName</code> does not populate the <code>zpool.cache</code> file.</p> <p>Type and dimension: string-scalar</p> <p>Default: /</p> <p>Example: /mnt</p>
ChkZFSMounts	<p>The <code>ChkZFSMounts</code> attribute enables the check to determine whether all the file systems are properly mounted for that ZFS storage pool when the <code>mountpoint</code> property is not set to <code>legacy</code>. The default value is <code>enabled</code> (set to 1).</p> <p>Type and dimension: boolean-scalar</p> <p>Default: 1</p>

Table 2-14 Optional Attributes

Optional Attribute	Description
FailMode	<p>The FailMode attribute controls the system behavior in the event of a catastrophic pool failure. The value of this attribute is used as the failmode option while importing the ZFS storage pool. The possible values are wait, continue, or panic.</p> <ul style="list-style-type: none"><li>■ wait: Blocks all I/O access to the pool until the device connectivity is recovered and the errors are cleared.</li><li>■ continue: Returns EIO to any new write I/O requests but allows reads to any of the remaining healthy devices.</li><li>■ panic: Halt the system and generates a system crash dump.</li></ul> <p>For more information about this attribute, refer to the <i>zpool man pages</i>.</p> <p>Type and dimension: string-scalar</p> <p>Default: continue</p> <p>Example: panic</p> <p><b>Note:</b> Symantec recommends to set FailMode to panic to effectively detect storage connectivity loss to the underlying disks of the pool.</p>
ForceOpt	<p>If this attribute is enabled (the value is set to 1), and if the following commands fail, then the commands are re-invoked with the <code>-f</code> option</p> <ul style="list-style-type: none"><li>■ zpool export in the offline entry point</li><li>■ zpool export in the clean entry point</li><li>■ zpool import in the online entry point</li></ul> <p>For more information about this attribute, refer to the <i>zpool man pages</i>.</p> <p>Type and dimension: boolean-scalar</p> <p>Default: 1</p> <p>Example: 1</p>

**Table 2-14** Optional Attributes (*continued*)

Optional Attribute	Description
ForceRecoverOpt	<p>If this attribute is enabled (the value is set to 1), and if the zpool import command fails, then the zpool import command is reinvoked with the <code>-F</code> option.</p> <p>For more information about this attribute, refer to the <i>zpool man pages</i>.</p> <p>Type and dimension: boolean-scalar</p> <p>Default: 0</p> <p>Example: 1</p>
DeviceDir	<p>Specifies the directories that the zpool import command searches for devices or files. Each directory is passed to the zpool import command with the <code>-d</code> option. The directory path must exist and be absolute. For more information, see the zpool manual pages.</p> <p>To reduce the time taken for zpool imports, create links to the devices constituting the zpool in a directory and provide that directory path in the DeviceDir attribute.</p> <p>Type and dimension: string-vector</p> <p>Default: n/a</p> <p>Example: <code>"/dev/vx/dmp"</code></p>
ZoneResName	<p>Use the ZoneResName attribute when a non-global zone needs the Zpool resource. In this case, supply the ZoneResName attribute with the name of the Zone resource.</p> <p>Type and dimension: string-scalar</p> <p>Default: n/a</p> <p>Example: <code>zone1</code></p>

## Resource type definition for Zpool agent

```

type Zpool (
  static str ArgList[] = { PoolName, AltRootPath, ChkZFSMounts,
    ZoneResName, "ZoneResName:State", DeviceDir, FailMode,
    ForceOpt, ForceRecoverOpt }
  str PoolName
  str AltRootPath
  boolean ChkZFSMounts = 1
  str ZoneResName

```

```
str DeviceDir[]
str FailMode = continue
boolean ForceOpt = 1
boolean ForceRecoverOpt = 0
)
```

## Sample configurations for Zpool agent

A main.cf example that shows the Zpool agent configuration.

```
include "types.cf"
cluster clus1 (
UserNames = { admin = dqrJqlQnrMrrPzrLqo,
z_zone_res = dOMoOTnNMlMSlVPnOT,
z_dummy_res = bIJbIDiFJeJhRJdIG }
Administrators = { admin }
)
system sysA (
)
system sysB (
)
group tstzfs (
SystemList = { sysA = 0, sysB = 1 }
AutoStartList = { sysA, sysB }
ContainerInfo = { Name = z1, Type = Zone, Enabled = 1 }
Administrators = { z_zone_res }
)
Zone zone_res (
)
Zpool legacy_res (
PoolName = legacypool
ZoneResName = zone_res
)
Zpool tstzone_res (
PoolName = tstzonepool
ZoneResName = zone_res
)
Zpool zpool_res (
PoolName = tank
AltRootPath = "/mytank"
)
Application custom_app (
```

```
StartProgram = "/mytank/tank/startapp"  
StopProgram = "/mytank/tank/stopapp"  
MonitorProcesses = { "/mytank/tank/mondaemon" }  
)  
custom_app requires zpool_res  
zone_res requires legacy_res  
zone_res requires tstzone_res
```

## Debug log levels for Zpool agent

The Zpool agent uses following debug log levels:

DBG\_1, DBG\_2, and DBG\_5

# Network agents

This chapter includes the following topics:

- [About the network agents](#)
- [IP agent](#)
- [NIC agent](#)
- [IPMultiNIC agent](#)
- [MultiNICA agent](#)
- [About the IPMultiNICB and MultiNICB agents](#)
- [IPMultiNICB agent](#)
- [MultiNICB agent](#)
- [DNS agent](#)

## About the network agents

Use network agents to provide high availability for networking resources.

All networking agents IP, NIC, IPMultiNIC, MultiNICA, IPMultiNICB and MultiNICB agents support IPv4 as well as IPv6 protocols.

## Agent comparisons

Agent comparisons may be made as described in the following sections.

### IP and NIC agents

The IP and NIC agents:



- Monitor a single NIC

## **IPMultiNIC and MultiNICA agents**

The IPMultiNIC and MultiNICA agents:

- Monitor single or multiple NICs
- Check the backup NICs at fail over
- Use the original base IP address when failing over
- Provide slower failover compared to MultiNICB but can function with fewer IP addresses
- Have only one active NIC at a time

## **IPMultiNICB and MultiNICB agents**

The IPMultiNICB and MultiNICB agents:

- Monitor single or multiple NICs
- Check the backup NICs as soon as it comes up
- Require a pre-assigned base IP address for each NIC
- Do not fail over the original base IP address
- Provide faster fail over compared to MultiNICA but require more IP addresses
- Have more than one active NIC at a time

## **802.1Q trunking**

The IP/NIC, IPMultiNIC/MultiNICA, and IPMultiNICB/MultiNICB agents support 802.1Q trunking.

On Solaris, VLAN is not supported on the Fast Ethernet interfaces. (for example, hme/qfe interfaces).

You need to specify the VLAN interfaces, for example: bge20001 , bge30001, as the base interfaces in the device list in the main.cf file. You also must make sure that the IP addresses that are assigned to the interfaces of a particular VLAN are in the same subnet.

## **Link aggregation support**

The link aggregation feature aggregates multiple network interfaces so that they appear as a single interface. For example, you can combine bge0 and bge1 and name the combined interface aggr100.

You can use the NIC, MultiNICA, or MultiNICB agents to monitor an aggregated interface. You can use the IP, IPMultiNIC, or IPMultiNICB agent respectively to configure and monitor an IP address on the aggregated interface.

All VCS networking agents support link aggregation. However, VCS has no control over the local adapter swapping performed by the link aggregation module. For guidelines on creating and managing link aggregations, refer to the topic Overview of Link Aggregations in the System Administration Guide: IP Services guide available on the Oracle Solaris documentation website.

---

**Note:** After you set up an aggregated interface, the constituting interfaces are no longer configurable. Hence, you must specify aggregated interfaces while configuring the Device attribute of IP, NIC, MultiNICA, or MultiNICB resources.

---

## IP agent

The IP agent manages the process of configuring a virtual IP address and its subnet mask on an interface. The virtual IP address must not be in use. You can use this agent when you want to monitor a single IP address on a single adapter.

The interface must be enabled with a physical (or administrative) base IP address before you can assign it a virtual IP address.

This agent is zone-aware. The ContainerOpts resource type attribute for this type has a default value of 0 for RunInContainer and a default value of 1 for PassCInfo. Symantec recommends that you do not change these values.

Refer to the *Storage Foundation High Availability Virtualization Guide*.

## High availability fire drill for IP agent

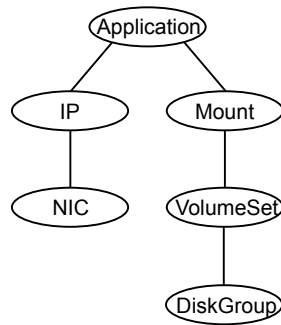
The high availability fire drill detects discrepancies between the VCS configuration and the underlying infrastructure on a node. These discrepancies might prevent a service group from going online on a specific node. For IP resources, the high availability fire drill:

- Checks for the existence of a route to the IP from the specified NIC
- Checks for the existence of the interface configured in the IP resource

For more information about using the high availability fire drill see the *Veritas Cluster Server Administrator's Guide*.

## Dependencies for IP agent

IP resources depend on NIC resources.

**Figure 3-1** Sample service group that includes an IP resource

## Agent functions for IP agent

Online	Configures the IP address to the NIC. Checks if another system is using the IP address. Uses the <code>ifconfig</code> command to set the IP address on a unique alias on the interface.
Action	<ul style="list-style-type: none"><li>■ <code>route.vfd</code> Checks for the existence of a route to the IP from the specified NIC.</li><li>■ <code>device.vfd</code> Checks for the existence of the interface configured in the Device attribute.</li></ul>
Offline	Brings down the IP address that is specified in the Address attribute.
Monitor	Monitors the interface to test if the IP address that is associated with the interface is alive.
Clean	Brings down the IP address that is specified in the Address attribute.

## State definitions for IP agent

The state definitions for this agent follow:

ONLINE	Indicates that the device is up and the specified IP address is assigned to the device.
OFFLINE	Indicates that the device is down or the specified IP address is not assigned to the device.
UNKNOWN	Indicates that the agent could not determine the state of the resource or that the resource attributes are invalid.

**FAULTED** Indicates that the IP address could not be brought online, usually because the NIC configured in the IP resource is faulted or the IP address was removed out of VCS control.

## Attributes for IP agent

For Solaris:

**Table 3-1** Required attributes

Required attribute	Description
Address	A virtual IP address that is associated with the interface. Note that the address you specify must not be the same as the configured physical IP address, but should be on the same network.  Type and dimension: string-scalar  Example: "192.203.47.61"  IPv6: "2001::10"
Device	The name of the NIC device that is associated with the IP address. Requires the device name without an alias.  Type and dimension: string-scalar  Example: "e1000g0"
One of the following attribute: <ul style="list-style-type: none"><li>NetMask</li><li>PrefixLen</li></ul>	See <a href="#">Table 3-2</a> on page 84.

**Table 3-2** Optional attributes

Optional attribute	Description
ArpDelay	The number of seconds to sleep between configuring an interface and sending out a broadcast to inform routers about this IP address.  Type and dimension: integer-scalar  Default: 1

**Table 3-2** Optional attributes (*continued*)

Optional attribute	Description
IfconfigTwice	<p>Causes an IP address to be configured twice using an <code>ifconfig</code> up-down-up sequence. Increases the probability of gratuitous ARP requests (generated by <code>ifconfig up</code>) to reach clients.</p> <p>Type and dimension: integer-scalar</p> <p>Default: 0</p>
PrefixLen	<p>This is the prefix for the IPv6 address represented as the CIDR value. When you use the IPv6 protocol, you must configure values for this attribute and the corresponding NIC agent's Device and Protocol attributes.</p> <p>Type-dimension: integer-scalar</p> <p>Range: 1 - 128</p> <p>Example: 64</p>
NetMask	<p>The subnet mask that is associated with the IP address of the resource. Specify the value of the netmask in decimal (base 10) or hexadecimal (base 16).</p> <p>You must configure this attribute if the IP address is an IPv4 address.</p> <p>Type and dimension: string-scalar</p> <p>Example: "255.255.248.0"</p>
Options	<p>Options for the <code>ifconfig</code> command.</p> <p>For complete list of <code>ifconfig</code> options refer to <i>ifconfig manpage</i>.</p> <p>Type and dimension: string-scalar</p> <p>Example: "failover"</p>

**Table 3-2** Optional attributes (*continued*)

Optional attribute	Description
RouteOptions	<p>Specifies the routing options that are passed to the <code>route add</code> command when the agent configures an interface. The RouteOptions attribute value is generally formed like this: "<i>destination gateway metric</i>".</p> <p>For details about the <code>route</code> command, refer to the man page for your operating system.</p> <p>When the value of this string is null, the agent does not add routes.</p> <p>Type and dimension: string-scalar</p> <p>Example: "192.100.201.0 192.100.201.7"</p> <p>In this example, the agent executes the "<code>route add 192.100.201.0 192.100.201.7</code>" command when it configures an interface.</p>
ExclusiveIPZone	<p>ExclusiveIPZone Specifies that a resource is configured for an exclusive IP zone. Set this value to 1 if resource is configured for exclusive IP zone. When set to 1, it requires a valid ContainerInfo to be configured in the service group.</p> <p>Type-dimension: boolean-scalar</p> <p>Default: 0</p>

## Resource type definition for IP agent

The resource definition for this agent on Solars follows:

```

type IP (
  static keylist RegList = { NetMask }
  static keylist SupportedActions = { "device.vfd", "route.vfd" }
  static str ArgList[] = { Device, Address, NetMask, Options,
  ArpDelay, IfconfigTwice, RouteOptions , PrefixLen,
  ExclusiveIPZone }
  static int ContainerOpts{} = { RunInContainer=0, PassCInfo=1 }
  str Device
  str Address
  str NetMask
  str Options
  int ArpDelay = 1
  int IfconfigTwice
  str RouteOptions

```

```
int PrefixLen
boolean ExclusiveIPZone = 0
)
```

## Sample configurations for IP agent

The sample configurations for this agent follow:

### Configuration 1

Configuration 1 for Solaris follows:

```
IP IP_192_203_47_61 (
Device = le0
Address = "192.203.47.61"
NetMask = "255.255.248.0"
)
```

### NetMask in decimal (base 10)

The NetMask for this agent follows:

```
IP IP_192_203_47_61 (
Device = e1000g0
Address = "192.203.47.61"
NetMask = "255.255.248.0"
)
```

### Configuration of NetMask in hexadecimal (base 16)

The NetMask for this agent follows:

```
IP IP_192_203_47_61 (
Device = e1000g0
Address = "192.203.47.61"
NetMask = "0xfffff800"
)
```

## Debug log levels for IP agent

The IP agent uses the following debug log levels:

DBG\_1, DBG\_3, DBG\_5

## NIC agent

The NIC agent monitors the configured NIC. If a network link fails, or if a problem arises with the NIC, the resource is marked FAULTED. You can use the agent to make a single IP address on a single adapter highly available. This resource's Operation value is None.

The ContainerName and ContainerType attributes are deprecated.

This agent is zone-aware. The ContainerOpts resource type attribute for this type has a default value of 0 for RunInContainer and a default value of 1 for PassCInfo. Symantec recommends that you do not change these values. Refer to the *Storage Foundation High Availability Virtualization Guide* for more information.

## High availability fire drill for NIC agent

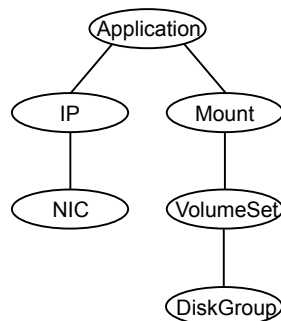
The high availability fire drill detects discrepancies between the VCS configuration and the underlying infrastructure on a node. These discrepancies might prevent a service group from going online on a specific node. For NIC resources, the high availability fire drill checks for the existence of the NIC on the host.

For more information about using the high availability fire drill, see the *Veritas Cluster Server Administrator's Guide*.

## Dependencies for NIC agent

The NIC resource does not depend on any other resources.

**Figure 3-2** Sample service group that includes a NIC resource



The NIC listed in the Device attribute must have a base IP address. The base IP address is the default IP address that is assigned to the physical interface of a host on a network. This agent does not configure network routes or base IP addresses.

Before you use this agent:



- Verify that the NIC has the correct base IP address and subnet mask.
- Verify that the NIC does not have built-in failover support. If it does, disable it.

## Agent functions for NIC agent

Monitor	<ul style="list-style-type: none"><li>■ Tests the network card and network link. Pings the network hosts or broadcast address of the interface to generate traffic on the network. Counts the number of packets passing through the device before and after the address is pinged. If the count decreases or remains the same, the resource is marked FAULTED. If the NetworkHosts list is empty, or the ping test fails, the agent sends a ping to the device's broadcast address to generate network traffic. The agent checks for any response to the broadcast request. If there is no reply to the broadcast ping, the resource faults.</li></ul>
Action	<ul style="list-style-type: none"><li>■ clearNICFaultInZone This action entry point clears the fault on the NIC device that is configured for Exclusive IP zone.</li><li>■ device.vfd Checks for the existence of the interface configured in the Device attribute.</li></ul>

## State definitions for NIC agent

The state definitions for this agent follow:

ONLINE	Indicates that the NIC resource is working.
FAULTED	Indicates that the NIC has failed.
UNKNOWN	Indicates the agent cannot determine the interface state. It may be due to an incorrect configuration.

## Attributes for NIC agent

**Table 3-3** Required attributes

Required attribute	Description
Device	Name of the NIC that you want to monitor.  Type and dimension: string-scalar Example: "e1000g0"
Protocol	Specifies the type of IP protocol (IPv4 or IPv6) that you want to use with the agent.  When you use the IPv6 protocol, you must configure values for this attribute, the Device attribute, and the corresponding IP agent's PrefixLen attribute.  Type-dimension: string-scalar Default: IPv4 Example: IPv6  When you configure this agent on IPv4, this attribute is optional.

**Table 3-4** Optional attributes

Optional attribute	Description
NetworkHosts	List of hosts on the network that are pinged to determine if the network connection is alive. You can use this attribute to help to save network capacity and reduce monitor time. Symantec recommends that you use the outgoing gateway routers for this value.  Enter the IP address of the host, instead of the host name, to prevent the monitor from timing out. DNS causes the ping to hang. If more than one network host is listed, the monitor returns ONLINE if at least one of the hosts is alive.  If an invalid network host address is specified or if there is mismatch in protocol of network host and Protocol attribute of the resource, the resource enters an UNKNOWN state. If you do not specify network hosts, the monitor tests the NIC by sending pings to the broadcast address on the NIC.  Type and dimension: string-vector Example: "166.96.15.22", "166.97.1.2"

**Table 3-4** Optional attributes (*continued*)

Optional attribute	Description
NetworkType	<p>Type of network. VCS supports only Ethernet.</p> <p>Type and dimension: string-scalar</p> <p>Default: "ether"</p>
PingOptimize	<p>Number of monitor cycles to detect if a configured interface is inactive. Use PingOptimize when you have not specified the NetworkHosts attribute.</p> <p>A value of 1 optimizes broadcast pings and requires two monitor cycles.</p> <p>A value of 0 performs a broadcast ping during each monitor cycle and detects the inactive interface within the cycle.</p> <p>Type and dimension: integer-scalar</p> <p>Default: 1</p>
ExclusiveIPZone	<p>ExclusiveIPZone Specifies that a resource is configured for an exclusive IP zone. Set this value to 1 if a resource is configured for exclusive IP zone. When set to 1, it requires a valid ContainerInfo to be configured in the service group.</p> <p>Type-dimension: boolean-scalar</p> <p>Default: 0</p>

## Resource type definition for NIC agent

The resource definition for this agent on Solaris follows:

```

type NIC (
static keylist SupportedActions = { "device.vfd",
"clearNICFaultInZone" }
static str ArgList[] = { Device, PingOptimize, NetworkHosts,
Protocol, NetworkType, ExclusiveIPZone }
static int ContainerOpts{} = { RunInContainer=0, PassCInfo=1 }
static int OfflineMonitorInterval = 60
static str Operations = None
str Device
int PingOptimize = 1
str NetworkHosts[]
str Protocol = IPv4
str NetworkType

```

```
boolean ExclusiveIPZone = 0
)
```

## Sample configurations for NIC agent

### Configuration without network hosts (using default ping mechanism) for NIC agent

```
NIC groupx_e1000g0 (
    Device = e1000g0
    PingOptimize = 1
)
```

### Configuration with network hosts for NIC agent

Network hosts for Solaris configuration follows:

```
NIC groupx_e1000g0 (
    Device = e1000g0
    NetworkHosts = { "166.93.2.1", "166.99.1.2" }
)
```

### IPv6 configuration for NIC agent

The following is a basic configuration for IPv6 with IP and NIC resources.

```
group nic_group (
    SystemList = { sysA = 0, sysB = 1 }
    Parallel = 1
)
NIC nic_resource (
    Device@sysA = bge0
    Device@sysB = bge1
    PingOptimize = 0
    Protocol = IPv6
    NetworkHosts@sysA = { "2001:db8:c18:2:214:4fff:fe96:11",
        "2001:db8:c18:2:214:4fff:fe96:1" }
    NetworkHosts@sysB = { "2001:db8:c18:2:214:4fff:fe96:1111",
        "2001:db8:c18:2:214:4fff:fe96:111" }
)
Phantom phantom_resource (
)
group ip_group (
    SystemList = { sysA = 0, sysB = 1 }
```

```
)  
IP ip_resource (  
Device@sysA = bge0  
Device@sysB = bge1  
Address = "2001:db8:c18:2:214:4fff:fe96:102"  
PrefixLen = 64  
)  
Proxy proxy_resource (  
TargetResName = nic_resource  
)  
ip_resource requires proxy_resource
```

## Exclusive IP Zone configuration for NIC agent

Following is the configuration example for Exclusive IP zone with NIC and IP resources. In the following sample, `nic_value` represents the base NIC name (for example, `bge0`) and `zone_name` is the name of the exclusive IP zone. (For more details about Zone resource configuration, refer to the Zone agent section.)

```
group grp1 (  
SystemList = { sysA = 0 }  
ContainerInfo@sysA = { Name = zone_name, Type = Zone,  
Enabled = 1 }  
AutoStartList = { sysA }  
Administrators = { z_zone_res_sysA }  
)  
IP ip_res (  
Device = nic_value  
Address = "166.93.3.10"  
NetMask = "255.255.255.0"  
ExclusiveIPZone = 1  
)  
NIC nic_res (  
Device = nic_value  
NetworkHosts = { "166.93.3.1" }  
ExclusiveIPZone = 1  
)  
Zone zone_res (  
)  
ip_res requires nic_res  
ip_res requires zone_res
```

Note that whenever a fault is detected for a NIC resource configured in an exclusive IP zone, perform the following steps to clear the fault.

- 1 Repair the device configured with NIC resource. Verify that the device is healthy (check for cable connectivity, network connectivity, and so on).
- 2 If the state of the exclusive IP zone on the system on which the NIC was faulted is:
  - Running: No action is required, and the next NIC monitor cycle will clear the fault after detecting the healthy NIC device.
  - NOT running: Clear the fault on the NIC device by invoking 'clearNICFaultInZone' action entry point for the NIC resource as follows:  

```
# hares -action nic_res clearNICFaultInZone -sys sysA
```

---

**Note:** When a NIC resource is configured for an Exclusive IP zone, Symantec recommends to set the ToleranceLimit attribute to a non-zero value.

---

With a NIC resource configured for an Exclusive IP zone, the NIC resource is monitored inside the zone when the zone is functional. While the zone is shutting down if the NIC monitor program is invoked, the monitor may falsely report the NIC resource as offline. This may happen if some of the networking services are offline but the zone is not completely shut down. Such reports can be avoided if you override and set the ToleranceLimit value to a non-zero value.

Calculate the ToleranceLimit value as follows: Time taken by a zone to completely shut down must be less than or equal to NIC resource's MonitorInterval value + (MonitorInterval value x ToleranceLimit value).

For example, if a zone takes 90 seconds to shut down and the MonitorInterval for NIC agent is set to 60 seconds (default value), set the ToleranceLimit value to 1.

## Debug log levels for NIC agent

The NIC agent uses the following debug log levels:

DBG\_1, DBG\_5

## IPMultiNIC agent

The IPMultiNIC agent manages the virtual IP address that is configured as an alias on one interface of a MultiNICA resource. If the interface faults, the agent works with the MultiNICA resource to fail over the virtual IP to a backup interface. If multiple service groups have IPMultiNIC resources associated with the same MultiNICA resource, only one group must have the MultiNICA resource. The other groups have Proxy resources pointing to it. You can use this agent for IP addresses on multiple-adaptor systems.

The ContainerName and ContainerType attributes are deprecated.

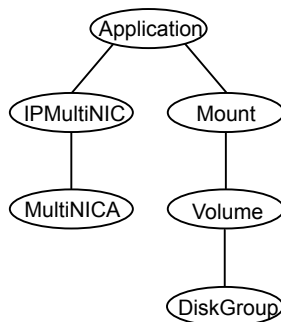
This agent is zone-aware. The ContainerOpts resource type attribute for this type has a default value of 0 for RunInContainer and a default value of 1 for PassCInfo. Symantec recommends that you do not change these values.

Refer to the *Storage Foundation High Availability Virtualization Guide*.

## Dependencies for IPMultiNIC agent

IPMultiNIC resources depend on MultiNICA resources. They can also depend on Zone resources.

**Figure 3-3** Sample service group that includes an IPMultiNIC resource



## Agent functions for IPMultiNIC agent

Online	Configures a virtual IP address on the active interface of the MultiNICA resource. Also sends out a gratuitous ARP.
Offline	Removes the virtual IP address from the active interface of the MultiNICA resource.
Monitor	Checks if the virtual IP address is configured on one interface of the MultiNICA resource.
Clean	Removes the virtual IP address from the interface of the MultiNICA resource.

## State definitions for IPMultiNIC agent

The state definitions for this agent follow:

ONLINE	Indicates that the specified IP address is assigned to one of the interfaces specified in the corresponding MultiNICA resource.
OFFLINE	Indicates that the specified IP address is not assigned to any interface of the MultiNICA resource.
UNKNOWN	Indicates that the agent can not determine the state of the resource. This state may be due to an incorrect configuration.
FAULTED	Indicates that the IP address could not be brought online, usually because all the NICs in the MultiNICA resource are faulted or the IP address was removed out of VCS control.

## Attributes for IPMultiNIC agent

**Table 3-5** Required attributes

Required attribute	Description
Address	<p>The logical IP address that the IPMultiNIC resource must handle. This IP address must be different than the base IP addresses in the MultiNICA resource.</p> <p>Type and dimension: string-scalar</p> <p>Example: IPv4: "10.128.10.14"</p> <p>IPv6: "2001:DB8::"</p>
MultiNICResName	<p>Name of the associated MultiNICA resource that determines the active NIC.</p> <p>Type and dimension: string-scalar</p> <p>Example: "mnic"</p>
One of the two attributes: <ul style="list-style-type: none"> <li>■ NetMask</li> <li>■ PrefixLen</li> </ul>	See <a href="#">Table 3-6</a> on page 97.



**Table 3-6** Optional attributes

Optional attribute	Description
IfconfigTwice	<p>Causes an IP address to be configured twice using an <code>ifconfig updown-up</code> sequence. Increases the probability of gratuitous ARP requests (generated by <code>ifconfig up</code>) to reach clients.</p> <p>Type and dimension: integer-scalar</p> <p>Default: 0</p>
NetMask	<p>For the IPv4 protocol, the netmask that is associated with the IP address of the resource. Specify the value of the netmask in decimal (base 10). You must configure this attribute if the IP address is an IPv4 address.</p> <p>Type and dimension: string-scalar</p> <p>Example: "255.255.248.0"</p>
Options	<p>The <code>ifconfig</code> command options for the virtual IP address.</p> <p>Type and dimension: string-scalar</p> <p>Example: "failover"</p> <p>For complete list of <code>ifconfig</code> options refer to <code>ifconfig</code> manpage.</p>
PrefixLen	<p>Specifies the prefix for the IPv6 address represented as the CIDR value.</p> <p>When you use the IPv6 protocol, you must configure values for this attribute and the MultiNICA agent's Device and Protocol attributes.</p> <p>Type-dimension: integer-scalar</p> <p>Range: 1 - 128</p> <p>Example: 64</p>

**Note:** On Solaris systems, Symantec Corporation recommends that you set the `RestartLimit` for IPMultiNIC resources to a greater-than-zero value. Setting this value helps to prevent the spurious faulting of IPMultiNIC resources during local failovers of MultiNICA. A local failover is an interface-to-interface failover of MultiNICA. See the *Veritas Cluster Server Administrator's Guide* for more information.

## Resource type definition for IPMultiNIC agent

The resource definition for this agent on Solaris follows:

```
type IPMultiNIC (
    static int ToleranceLimit = 1
    static str ArgList[] = { "MultiNICResName:Device", Address,
        NetMask, "MultiNICResName:ArpDelay", Options, "MultiNICRes
        Name:Probed", MultiNICResName, IfconfigTwice, PrefixLen }
    static int ContainerOpts{} = { RunInContainer=0, PassCInfo=1 }
    static int MonitorTimeout = 120
    str Address
    str NetMask
    str Options
    str MultiNICResName
    int IfconfigTwice
    int PrefixLen
)
```

## Sample configuration: IPMultiNIC and MultiNICA

Refer to the MultiNICA agent for more information.

### Configuration for IPMultiNIC agent

Sample configuration for IPMultiNIC and MultiNICA agents in Solaris:

```
group grp1 (
    SystemList = { sysa = 0, sysb = 1 }
    AutoStartList = { sysa }
)
MultiNICA mnic (
    Device@sysa = { le0 = "10.128.8.42", qfe3 = "10.128.8.42" }
    Device@sysb = { le0 = "10.128.8.43", qfe3 = "10.128.8.43" }
    NetMask = "255.255.255.0"
    ArpDelay = 5
    Options = "failover"
)
IPMultiNIC ip1 (
    Address = "10.128.10.14"
    NetMask = "255.255.255.0"
    MultiNICResName = mnic
    Options = "failover"
)
ip1 requires mnic
group grp2 (
    SystemList = { sysa = 0, sysb = 1 }
```

```
AutoStartList = { sysa }  
)  
IPMultiNIC ip2 (  
Address = "10.128.9.4"  
NetMask = "255.255.255.0"  
MultiNICResName = mnic  
Options = "failover"  
)  
Proxy proxy (  
TargetResName = mnic  
)  
ip2 requires proxy
```

## Debug log levels

The IPMultiNIC agent uses the following debug log levels:

DBG\_1

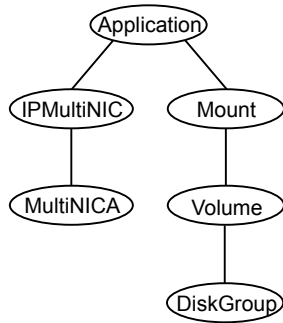
## MultiNICA agent

The MultiNICA agent represents a set of network interfaces and provides failover capabilities between them. You can use the agent to make IP addresses on multiple-adapter systems highly available or to monitor them. Each interface in a MultiNICA resource has a base IP address. You can use one base IP address for all interfaces, or you can specify a different IP address for use with each interface. The MultiNICA agent configures one interface at a time. If it does not detect activity on the configured interface, it configures a new interface and migrates IP aliases to it.

If an interface is associated with a MultiNICA resource, do not associate it with any other MultiNICA, MultiNICB, or NIC resource. If the same set of interfaces must be a part of multiple service groups, configure a MultiNICA resource in one of the service groups. In the other service groups, configure Proxy resources that point to the MultiNICA resource in the first service group.

## Dependencies for MultiNICA agent

The MultiNICA resource does not depend on any other resources.

**Figure 3-4** Sample service group that includes a MultiNICA resource

## Agent function for MultiNICA agent

Monitor	Checks the status of the active interface. If the agent detects a failure, it tries to migrate the IP addresses that are configured on that interface. If possible, it tries to migrate the addresses to the next available interface that is configured in the Device attribute.
---------	---

## State definitions for MultiNICA agent

The state definitions for this agent follow:

ONLINE	Indicates that one or more of the network interfaces listed in the Device attribute of the resource is in working condition.
FAULTED	Indicates that all of the network interfaces listed in the Device attribute failed.
UNKNOWN	Indicates that the agent cannot determine the state of the network interfaces that are specified in the Device attribute. This state may be due to incorrect configuration.

## Attributes for MultiNICA agent

For Solaris:

**Table 3-7** Required attributes

Required attribute	Description
Device	<p>List of interfaces and their base IP addresses.</p> <p>For each system you must localize the attribute with a separate base IP address.</p> <p>Type and dimension: string-association</p> <p>Example: { le0 = "10.128.8.42", qfe3 = "10.128.8.42" }</p>
Protocol	For more information, see <a href="#">Table 3-8</a> .
NetMask	For more information, see <a href="#">Table 3-8</a> .

**Table 3-8** Optional attributes

Optional attribute	Description
ArpDelay	<p>Number of seconds to sleep between configuring an interface and sending out a broadcast to inform routers about the base IP address.</p> <p>Type and dimension: integer-scalar</p> <p>Default: 1</p>
HandshakeInterval	<p>Computes the maximum number of tries the agent makes either to:</p> <ul style="list-style-type: none"> <li>■ ping a host (listed in the NetworkHosts attribute) when it fails over to a new NIC, or</li> <li>■ to ping the default broadcast address (depending on the attribute configured) when it fails over to a new NIC.</li> </ul> <p>If the value of the RetestInterval attribute is five (default), each try takes about 10 seconds.</p> <p>To prevent spurious failovers, the agent must try to contact a host on the network several times before it marks a NIC as FAULTED. Increased values result in longer failover times, whether between the NICs or from system to system in the case of FAULTED NICs.</p> <p>Type and dimension: integer-scalar</p> <p>Default: 20</p> <p>This value is the equivalent to two tries (20/10).</p>

**Table 3-8** Optional attributes (*continued*)

Optional attribute	Description
IfconfigTwice	<p>Causes an IP address to be configured twice, using an <code>ifconfig up-down-up</code> sequence. Increases the probability of gratuitous ARP requests (caused by <code>ifconfig up</code>) to reach clients.</p> <p>Type and dimension: integer-scalar</p>
NetMask	<p>Netmask for the base IP address. Specify the value of NetMask in decimal (base 10).</p> <p>You must configure this attribute if the IP address is an IPv4 address.</p> <p>Type and dimension: string-scalar</p> <p>Example: "255.255.255.0"</p>
NetworkHosts	<p>The list of hosts on the network that are pinged to determine if the network connection is alive. Enter the IP address of the host, instead of the host name, to prevent the monitor from timing out—DNS causes the ping to hang. If this attribute is unspecified, the monitor tests the NIC by pinging the broadcast address on the NIC. If more than one network host is listed, the monitor returns online if at least one of the hosts is alive. If an invalid network host address is specified or if there is a mismatch in protocol of the network host and Protocol attribute of resource, the resource enters an UNKNOWN state.</p> <p>Type and dimension: string-vector</p> <p>Example: "128.93.2.1", "128.97.1.2"</p>
Options	<p>The <code>ifconfig</code> options for the base IP address.</p> <p>Type and dimension: string-scalar</p> <p>Example: "failover"</p> <p>For complete list of <code>ifconfig</code> options refer to <code>ifconfig</code> manpage.</p>
PingOptimize	<p>Number of monitor cycles to detect if the configured interface is inactive. A value of 1 optimizes broadcast pings and requires two monitor cycles. A value of 0 performs a broadcast ping each monitor cycle and detects the inactive interface within the cycle.</p> <p>Type and dimension: integer-scalar</p> <p>Default: 1</p>

**Table 3-8** Optional attributes (*continued*)

Optional attribute	Description
RetestInterval	<p>Number of seconds to sleep between re-tests of a newly configured interface. A lower value results in faster local (interface-to-interface) failover.</p> <p>Type and dimension: integer-scalar</p> <p>Default: 5</p>
RouteOptions	<p>String to add a route when configuring an interface. Use only when configuring the local host as the default gateway.</p> <p>The string contains destination gateway metric. No routes are added if this string is set to NULL.</p> <p>Type and dimension: string-scalar</p> <p>Example: "default 166.98.16.103 0"</p>
Protocol	<p>Specifies the type of IP protocol (IPv4 or IPv6) that you want to use with the agent.</p> <p>When you use the IPv6 protocol, you must configure values for this attribute, the Device attribute, and the corresponding IPMultiNIC agent's PrefixLen attribute.</p> <p>Type-dimension: string-scalar</p> <p>Default: IPv4</p> <p>Example: IPv6</p>

## Resource type definition for MultiNICA agent

The resource definition for this agent on Solaris follows:

```

type MultiNICA (
static str ArgList[] = { Device, NetMask, ArpDelay,
RetestInterval, Options, RouteOptions, PingOptimize,
MonitorOnly, IfconfigTwice, HandshakeInterval, NetworkHosts,
Protocol }
static int OfflineMonitorInterval = 60
static int MonitorTimeout = 300
static str Operations = None
str Device{}
str NetMask
int ArpDelay = 1

```

```

int RetestInterval = 5
str Options
str RouteOptions
int PingOptimize = 1
int IfconfigTwice
int HandshakeInterval = 20
str NetworkHosts[]
str Protocol = IPv4
)

```

## Notes for MultiNICA agent

- If all interfaces configured in the Device attribute are down, the MultiNICA agent faults the resource after a two-three minute interval. This delay occurs because the MultiNICA agent tests the failed interface several times before it marks the resource OFFLINE. Engine logs record a detailed description of the events during a failover.
- The engine log is in `/var/VRTSvcs/log/engine_A.log`.
- The MultiNICA agent supports only one active interface on one IP subnet; the agent does not work with multiple active interfaces on the same subnet.
- On Solaris, for example, you have two active NICs, hme0 (10.128.2.5) and qfe0 (10.128.2.8). You configure a third NIC, qfe1, as the backup NIC to hme0. The agent does not fail over from hme0 to qfe1 because all ping tests are redirected through qfe0 on the same subnet. The redirect makes the MultiNICA monitor return an online status. Note that using ping -i does not enable the use of multiple active NICs.
- Before you start VCS, configure the primary NIC with the correct broadcast address and netmask.
- Set the NIC here: `/etc/hostname.nic`
- Set the netmask here: `/etc/netmasks`

## Using RouteOptions for MultiNICA agent

The RouteOptions attribute is useful only when the default gateway is your own host.

For example, if the default gateway and hme0 are both set to 10.128.8.42, the output of the `netstat -rn` command resembles:

```

Destination      Gateway          Flags Ref    Use   Interface
-----

```



10.0.0.0	10.128.8.42	U	1	2408	hme0
224.0.0.0	10.128.8.42	U	1	0	hme0
default	10.128.8.42	UG	1	2402	hme0
127.0.0.1	127.0.0.1	UH	54	44249	lo0

If the RouteOptions attribute is not set and hme0 fails, the MultiNICA agent migrates the base IP address to another NIC (such as qfe0). The default route is no longer configured because it was associated with hme0. The display resembles:

Destination	Gateway	Flags	Ref	Use	Interface
10.0.0.0	10.128.8.42	U	1	2408	qfe0
224.0.0.0	10.128.8.42	U	1	0	qfe0
127.0.0.1	127.0.0.1	UH	54	44249	lo0

If the RouteOptions attribute defines the default route, the default route is reconfigured on the system. For example:

```
RouteOptions@sya = "default 10.128.8.42 0"
RouteOptions@sysb = "default 10.128.8.43 0"
```

## Sample configurations for MultiNICA agent

The sample configurations for this agent follow:

### MultiNICA and IPMultiNIC

In the following example, two nodes, sya and sysb, each have a pair of network interfaces, le0 and qfe3. In this example, the two interfaces, le0 and qfe3, have the same base, or physical, IP address. Note the lines beginning Device@sya and Device@sysb; the use of different physical addresses shows how to localize an attribute for a particular host.

The MultiNICA resource fails over only the physical IP address to the backup NIC during a failure. The IPMultiNIC agent configures the logical IP addresses. The resources ip1 and ip2, shown in the following example, have the Address attribute that contains the logical IP address. If a NIC fails on sya, the physical IP address and the two logical IP addresses fails over from le0 to qfe3. If qfe3 fails, the address fails back to le0 if le0 is reconnected.

However, if both the NICs on sya are disconnected, the MultiNICA and IPMultiNIC resources work in tandem to fault the group on sya. The entire group now fails over to sysb.

If you have more than one group using the MultiNICA resource, the second group can use a Proxy resource. The Proxy resource points to the MultiNICA resource in

the first group. The Proxy resource prevents redundant monitoring of the NICs on the same system. The IPMultiNIC resource is always made dependent on the MultiNICA resource. See the IPMultiNIC agent for more information.

```
group grp1 (
SystemList = { sysa = 0, sysb = 1 }
AutoStartList = { sysa }
)
MultiNICA mnic (
Device@sysa = { le0 = "10.128.8.42", qfe3 = "10.128.8.42" }
Device@sysb = { le0 = "10.128.8.43", qfe3 = "10.128.8.43" }
NetMask = "255.255.255.0"
ArpDelay = 5
Options = "failover"
)
IPMultiNIC ip1 (
Address = "10.128.10.14"
NetMask = "255.255.255.0"
MultiNICResName = mnic
Options = "failover"
)
ip1 requires mnic
group grp2 (
SystemList = { sysa = 0, sysb = 1 }
AutoStartList = { sysa }
)
IPMultiNIC ip2 (
Address = "10.128.9.4"
NetMask = "255.255.255.0"
MultiNICResName = mnic
Options = "failover"
)
Proxy proxy (
TargetResName = mnic
)
ip2 requires proxy
```

## IPv6 configuration for MultiNICA agent

The following is a basic configuration for IPv6.

```
group mnica_group (
SystemList = { sysA = 0, sysB = 1 }
)
```

```
IPMultiNIC ipmnic_res (  
  Address = "2007:192::1627:161"  
  MultiNICResName = mnica_res  
  PrefixLen = 64  
)  
MultiNICA mnica_res (  
  Device @sysA = { e1000g1 = "fe80::214:4fff:fe96:ae0a",  
    e1000g3 = "fe80::214:4fff:fe96:ae0b" }  
  Device @sysB = { e1000g1 = "fe80::214:4fff:fe96:ae1a",  
    e1000g3 = "fe80::214:4fff:fe96:ae1b" }  
  Protocol = IPv6  
)  
ipmnic_res requires mnica_res
```

## Debug log levels for MultiNICA agent

The MultiNICA agent uses the following debug log levels:

DBG\_1

## About the IPMultiNICB and MultiNICB agents

The IPMultiNICB and the MultiNICB agents can handle multiple NIC connections. Due to differences in the way that each platform handles its networking connections, these agents vary in design between platforms.

## Checklist to ensure the proper operation of MultiNICB

For the MultiNICB agent to function properly, you must satisfy each item in the following list:

- Each interface must have a unique MAC address.
- A MultiNICB resource controls all the interfaces on one IP subnet.
- At boot time, you must configure and connect all the interfaces that are under the MultiNICB resource and give them base IP addresses.
- All base IP addresses for the MultiNICB resource must belong to the same subnet as the virtual IP address.
- Reserve the base IP addresses, which the agent uses to test the link status, for use by the agent. These IP addresses do not get failed over.
- The IgnoreLinkStatus attribute is set to 1 (default) when using trunked interfaces.

- If you specify the NetworkHosts attribute, then that host must be on the same subnet as the base IP addresses for the MultiNICB resource.
- Test IP addresses have "nofailover" and "deprecated" flags set at boot time.
- /etc/default/mpathd has TRACK\_INTERFACES\_ONLY\_WITH\_GROUPS=yes.
- If you are not using Solaris in.mpathd, all MultiNICB resources on the system have the UseMpathd attribute set to 0 (default). You cannot run in.mpathd on this system.
- If you are using Solaris in.mpathd, all MultiNICB resources on the system have the UseMpathd attribute set to 1.

## IPMultiNICB agent

The IPMultiNICB agent works with the MultiNICB agent. The agent configures and manages virtual IP addresses (IP aliases) on an active network device that the MultiNICB resource specifies. When the MultiNICB agent reports a particular interface as failed, the IPMultiNICB agent moves the virtual IP address to the next active interface. You can use this agent for IP addresses on multiple-adapter systems.

If multiple service groups have IPMultiNICB resources associated with the same MultiNICB resource, only one group should have a MultiNICB resource. The other groups should have a proxy resource pointing to the MultiNICB resource.

For the MultiNICB and IPMultiNICB agents, VCS supports Oracle trunking.

The ContainerName and ContainerType attributes are deprecated.

This agent is zone-aware. The ContainerOpts resource type attribute for this type has a default value of 0 for RunInContainer and a default value of 1 for PassCInfo. Symantec recommends that you do not change these values.

Refer to the *Storage Foundation High Availability Virtualization Guide*.

The value of the MonitorInterval attribute for the MultiNICB type must be less than its value for the IPMultiNICB type. The IPMultiNICB agent relies on the MultiNICB agent to accurately report the state of the NICs. If the value of the MonitorInterval of the IPMultiNICB agent is less than the interval for the MultiNICB agent, then in some monitor cycles the potential exists for the MultiNICB agent to provide the IPMultiNICB agent stale information.

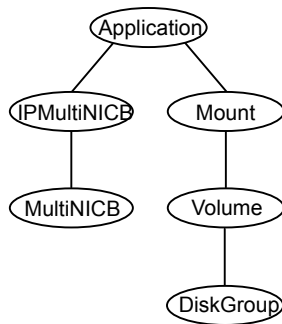
The default value for the MonitorInterval attribute for IPMultiNICB is 30 seconds, and the minimum and default value for MultiNICB is 10 seconds.

## Dependencies for IPMultiNICB agent

IPMultiNICB resources depend on MultiNICB resources.

They can also depend on Zone resources.

**Figure 3-5** Sample service group that includes an IPMultiNICB resource



## Requirements for IPMultiNICB

The following conditions must exist for the IPMultiNICB agent to function correctly:

- The MultiNICB agent must be running to inform the IPMultiNICB agent of the available interfaces.
- One IPMultiNICB agent can control only one virtual IP address.

## Agent functions for IPMultiNICB agent

Online	Finds a working interface with the appropriate interface alias or interface name, and configures the virtual IP address on it.
Offline	Removes the virtual IP address.
Clean	Removes the virtual IP address.
Monitor	If the virtual IP address is not configured as an alias on one of the working interfaces under a corresponding MultiNICB resource, monitor returns OFFLINE. If the current interface fails, the agent fails over the virtual IP address to the next available working interface that is within the MultiNICB resource on the same node. If no working interfaces are available then monitor returns OFFLINE.

## State definitions for IPMultiNICB agent

The state definitions for this agent follow:

ONLINE	Indicates that the IP address is up on one of the working network interfaces of the MultiNICB resource. The IP address is specified in the Address attribute. The MultiNICB resource is specified in the BaseResName attribute.
OFFLINE	Indicates that the IP address is not up on any of the network interfaces of the MultiNICB resource. The IP address is specified in the Address attribute. The MultiNICB resource is specified in the BaseResName attribute.
UNKNOWN	Indicates that the agent cannot determine the status of the virtual IP address that is specified in the Address attribute.
FAULTED	Indicates that the virtual IP address could not be brought online, usually because all the interfaces configured in the MultiNICB resource have failed or the virtual IP address was removed out of VCS control.

## Attributes for IPMultiNICB agent

For Solaris:

**Table 3-9** Required attributes

Required attribute	Description
Address	The logical IP address that the IPMultiNICB resource must handle. This IP address must be different than the base or test IP addresses in the MultiNICB resource. Type and dimension: string-scalar Example: "10.112.10.15"
BaseResName	Name of MultiNICB resource from which the IPMultiNICB resource gets a list of working interfaces. The logical IP address is placed on the physical interfaces according to the device number information. Type and dimension: string-scalar Example: "gnic_n"

**Table 3-9** Required attributes (*continued*)

Required attribute	Description
<p>One of the two attributes:</p> <ul style="list-style-type: none"> <li>■ NetMask</li> <li>■ PrefixLen</li> </ul>	<p>See <a href="#">Table 3-10</a> on page 111.</p>

**Table 3-10** Optional attributes

Optional attribute	Description
DeviceChoice	<p>Indicates the preferred NIC where you want to bring the logical IP address online. Specify the device name or NIC alias as determined in the Device attribute of the MultiNICB resource.</p> <p>Type and dimension: string-scalar</p> <p>Default: 0</p> <p>Examples: "qfe0" and "1"</p>
RouteOptions	<p>String to add or delete a route when configuring or unconfiguring an interface. Use the attribute only when configuring the local host as the default gateway.</p> <p>This string contains "<i>destination gateway metric route-add-modifiers</i>". No routes are added or deleted if this string is set to NULL. When DeleteRouteOptions attribute is not configured, RouteOptions attribute is used for adding and deleting the route. When DeleteRouteOptions attribute is configured, RouteOptions attribute is used to add route and DeleteRouteOptions attribute is used to delete route.</p> <p>Example: "default 166.98.16.103 0 -setsrc 166.98.16.10"</p>
DeleteRouteOptions	<p>String to delete a route when un-configuring an interface.</p> <p>When RouteOptions and DeleteRouteOptions attributes are configured, RouteOptions attribute is used to add route and DeleteRouteOptions attribute is used to delete route. When RouteOptions attribute is not configured, DeleteRouteOptions attribute is ignored.</p> <p>Example: "default 166.98.16.103"</p>

**Table 3-10** Optional attributes (*continued*)

Optional attribute	Description
IgnoreMultiNICBFailure	<p>Set this value to ignore a MultiNICB resource failure when all configured interfaces fail.</p> <p>A value of 1 for this attribute causes the IPMultiNICB agent to ignore the failure that its underlying MultiNICB resource detects.</p> <p>A value of 0 for this attribute causes the IPMultiNICB agent to detect network failure.</p> <p>When the value of this attribute is 1, the value for the MultiNICB LinkTestRatio attribute cannot be 0.</p> <p>Type and dimension: integer-scalar</p> <p>Default: 0</p>
Options	<p>Options for the ifconfig command.</p> <p>Type and dimension: string-scalar</p> <p>Example: "failover"</p>
PrefixLen	<p>This is the prefix for the IPv6 address represented as the CIDR value.</p> <p>When you use the IPv6 protocol, you must configure values for this attribute and the corresponding MultiNICB agent's Device and Protocol attributes.</p> <p>Type-dimension: integer-scalar</p> <p>Range: 1 - 128</p> <p>Example: 64</p>
NetMask	<p>The netmask that is associated with the logical IP address.</p> <p>This attribute is required if you configure this resource for IPv4 protocol.</p> <p>Type and dimension: string-scalar</p> <p>Example: "255.255.255.0"</p>



---

**Note:** The value of the `ToleranceLimit` static attribute is 1. A value of 1 avoids spurious agent faults in the multi-pathing mode while Oracle's `mpathd` daemon migrates the IP address from one interface to another. Due to the change in the `ToleranceLimit` attribute, the value of the `MonitorInterval` static attribute is now 30 seconds. The 30-second value means that the agent tries to online the resource twice a minute. This value ensures that the overall fault detection time is still 60 seconds.

---

## Resource type definition for IPMultiNICB agent

The resource definition for this agent on Solaris follows:

```
type IPMultiNICB (
  static int ToleranceLimit = 1
  static int MonitorInterval = 30
  static int OnlineRetryLimit=1
  static str ArgList[] = { BaseResName, Address, NetMask,
  DeviceChoice, RouteOptions, DeleteRouteOptions, PrefixLen,
  IgnoreMultiNICBFailure, "BaseResName:Protocol", Options }
  static int ContainerOpts{} = { RunInContainer=0, PassCInfo=1 }
  str BaseResName
  str Address
  str NetMask
  str DeviceChoice = 0
  str RouteOptions
  str DeleteRouteOptions
  str Options
  int PrefixLen
  int IgnoreMultiNICBFailure = 0
)
```

## Manually migrating a logical IP address for IPMultiNICB agent

Use the `haipswitch` command to migrate the logical IP address from one interface to another.

This command shows the status of the interfaces for the specified MultiNICB resource:

```
# haipswitch -s MultiNICB_resname
```

In the following example, the command checks that both the *from* and *to* interfaces are associated with the specified MultiNICB resource. The command also checks if the *to* interface works. If the interface does not work, the command aborts the

operation. It then removes the IP address on the *from* logical interface and configures the IP address on the *to* logical interface. It finally erases any previous failover information that is created by MultiNICB for this logical IP address.

```
# haipswitch MultiNICB_resname IPMultiNICB_resname ip_address  
<netmask|prefix> from to [route_options]
```

## Sample configurations for IPMultiNICB agent

The sample configurations for the IPMultiNICB and MultiNICB agent follows:

### Other sample configurations for IPMultiNICB and MultiNICB

Refer to the sample configurations in the MultiNICB agent.

## Debug log levels for IPMultiNICB agent

The IPMultiNICB agent uses the following debug log levels:

DBG\_1, DBG\_2, DBG\_3, DBG\_4, DBG\_5

## MultiNICB agent

The MultiNICB agent works with the IPMultiNICB agent. It allows IP addresses to fail over to multiple interfaces on the same system before VCS tries to fail over to another system. You can use the agent to make IP addresses on multiple-adapter systems highly available or to monitor them.

When you use the MultiNICB agent, you must configure the interfaces before putting them under the agent's control. You must configure all the interfaces in a single MultiNICB resource with the base IP addresses that are in the same subnet.

If multiple service groups have IPMultiNICB resources associated with the same MultiNICB resource, only one group should have the MultiNICB resource. The other groups can have a proxy resource pointing to it.

For the MultiNICB and IPMultiNICB agents, VCS supports Oracle trunking.

For the MultiNICB and IPMultiNICB agents, VCS supports either IPv4 or IPv6.

The value of the MonitorInterval attribute for the MultiNICB type must be less than its value for the IPMultiNICB type. The IPMultiNICB agent relies on the MultiNICB agent to accurately report the state of the NICs. If the value of the MonitorInterval of the IPMultiNICB agent is less than the interval for the MultiNICB agent, then in some monitor cycles the potential exists for the MultiNICB agent to provide the IPMultiNICB agent stale information.

The default value for the MonitorInterval attribute for IPMultiNICB is 30 seconds, and the minimum and default value for MultiNICB is 10 seconds.

## Base and Multi-pathing modes for MultiNICB agent

You can use the MultiNICB agent in one of two modes that follow:

- Base mode
- Multi-pathing mode

## Oracle trunking for MultiNICB agent

You can configure MultiNICB for use with a single trunk head or multiple trunk heads. You need to set the value of the IgnoreLinkStatus attribute to 1. You must also ensure that all interfaces that belong to the same MultiNICB resource are in the same subnet.

## The haping utility for MultiNICB agent

Use the haping utility (`/opt/VRTSvcs/bin/MultiNICB/haping`) to test each interface before you configure the MultiNICB resource. This utility takes the interface as an argument. You can use this utility to perform a link test, a broadcast ping, or to ping a specific remote host. Symantec recommends that the administrator perform a test ping with the remote host before adding it to the NetworkHosts parameter. Note that the remote host should be on the same network as the interface from which you are performing the test ping.

Link test only on interface bge0:

```
haping -l bge0
```

Ping a remote host 10.10.10.10 from interface bge0:

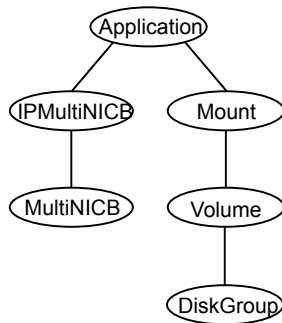
```
haping -g 10.10.10.10 bge0
```

Ping a remote IPv6 host from interface bge0:

```
haping -g fe80::1 bge0
```

## Dependencies for MultiNICB agent

The MultiNICB resource does not depend on any other resources.

**Figure 3-6** Sample service group that includes a MultiNICB resource

## Agent functions for MultiNICB agent

Open	Allocates an internal structure to store information about the resource.
Close	Frees the internal structure that is used to store information about the resource.
Monitor	Checks the status of each physical interface. Writes the status information to the export information file for IPMultiNICB resources to read it.  Performs a failover. Performs failback if the value of the Failback attribute is 1.

## State definitions for MultiNICB agent

ONLINE	Indicates that one or more of the network interfaces listed in the Device attribute of the resource is in working condition.
UNKNOWN	Indicates that the MultiNICB resource is not configured correctly.
FAULTED	Indicates that all of the network interfaces listed in the Device attribute failed.

## Attributes for MultiNICB agent

For Solaris:

**Table 3-11** Required attributes

Required attribute	Description
Device	<p>List of NICs that you want under MultiNICB control.</p> <p>For IPv4, you must manually configure the test IP addresses on each NIC. This address must be the base IP address (the first address) on that NIC.</p> <p>For IPv6, VCS uses link local addresses as the test IP addresses. You do not need to configure the test IP address.</p> <p>List of NICs that you want under MultiNICB control, and the failover order of those NICs. The IPMultiNICB agent uses the NIC aliases to configure IP addresses. The IPMultiNICB agent uses these interface aliases to determine the order of the interface on which to bring the IP addresses online.</p> <p>When you use the IPv6 protocol, you must configure values for this attribute, the Protocol attribute, and the corresponding IPMultiNICB agent's PrefixLen attribute.</p> <p>Type and dimension: string-association</p> <p>Examples:</p> <pre>Device = { "qfe0" = 0, "qfe1" = 1 }</pre>
Protocol	<p>Required to use the IPv6 protocol.</p> <p>See <a href="#">Table 3-12</a> on page 118.</p>
IPMPDevice (Solaris 11 only)	<p>Set the value of the attribute to the name of the IPMP interface created for interfaces under MultiNICB resource control. The value of the attribute must be set to a valid IPMP interface name and the value of UseMpathd attribute must be set to 1.</p> <p>Example: "ipmp0"</p> <p><b>Note:</b> Before you configure the attribute, you want to configure an IP Multipathing (IPMP) interface for the interfaces under MultiNICB resource control.</p> <p>See <a href="#">"Configuring MultiNICB and IPMultiNICB agents on Solaris 11"</a> on page 127.</p>

## Optional attributes for Base and Mpathd modes for MultiNICB agent

**Table 3-12** Optional attributes for Base and Mpathd modes

Optional attribute	Description
DefaultRouter	<p>This attribute is the IP address of the default router on the subnet. If you specify this value, the agent removes the default route when the resource goes offline. The agent adds the route back when the group returns online.</p> <p>You must specify this attribute if multiple IP subnets exist on one host. If you do not specify the value, the packets cannot be routed properly when the subnet corresponding to the first default route goes down.</p> <p>Type and dimension: string-scalar</p> <p>Default: 0.0.0.0</p> <p>Example: "192.1.0.1"</p>
GroupName	<p>The GroupName attribute is the name of the IPMP group that you want to assign to the interfaces under the control of the agent. The name's length should not exceed 31 bytes characters. If this attribute is not specified, the MultiNICB resource name is configured as IPMP group name.</p> <p>Type and dimension: string-scalar</p> <p>Example: "IPMPgrp1"</p>
MpathdCommand	<p>This value is the path to the mpathd executable. Use MpathdCommand to kill or restart mpathd. See the UseMpathd attribute for details.</p> <p>Type and dimension: string-scalar</p> <p>Default: /usr/lib/inet/in.mpathd</p>

**Table 3-12** Optional attributes for Base and Mpathd modes (*continued*)

Optional attribute	Description
UseMpathd	<p>The legal values for this attribute are 0 and 1. All the MultiNICB resources on one system must have the same value for this attribute.</p> <p>If the value of the attribute is 0, in.mpathd is automatically killed on that system. For more information about mpathd, refer to the Oracle documentation.</p> <p>If the value of the attribute is 1, MultiNICB assumes that mpathd (in.mpathd) is running. This value restarts mpathd if it is not running already.</p> <p>Type and dimension: integer-scalar</p> <p>Default: 0</p>
Protocol	<p>Specifies the type of IP protocol (IPv4 or IPv6) that you want to use with the agent.</p> <p>When you use the IPv6 protocol, you must configure values for this attribute, the Device attribute, and the corresponding IPMultiNICB agent's PrefixLen attribute.</p> <p>Type-dimension: string-scalar</p> <p>Default: IPv4</p> <p>Example: IPv6</p>

## Optional attributes for Base mode for MultiNICB agent

**Table 3-13** Optional attributes for Base mode

Optional attribute	Description
Failback	<p>If the value of the attribute is 1, the virtual IP addresses are failed back to the original physical interface whenever possible. A value of 0 disables this behavior.</p> <p>Type and dimension: integer-scalar</p> <p>Default: 0</p>

**Table 3-13** Optional attributes for Base mode (*continued*)

Optional attribute	Description
IgnoreLinkStatus	<p>If the value of the attribute is 1, the agent ignores the driver-reported interface status while testing the interfaces. If the value of the attribute is 0, the agent reports the interface status as DOWN if the driver-reported interface status indicates the DOWN state. Using interface status for link testing may considerably speed up failovers.</p> <p>When you use trunked interfaces, you must set the value of this attribute to 1. Otherwise set it to 0.</p> <p>Type and dimension: integer-scalar</p> <p>Default: 1</p>



**Table 3-13** Optional attributes for Base mode (*continued*)

Optional attribute	Description
LinkTestRatio	<p>This attribute is the ratio of:</p> <ul style="list-style-type: none"><li>■ The total monitor cycles to</li><li>■ The monitor cycles in which the agent tests the interfaces by sending packets</li></ul> <p>At all other times, the agent tests the link by checking the "link-status" as reported by the device driver. Checking the "link-status" is a faster way to check the interfaces, but only detects cable disconnection failures.</p> <p>If the value of the attribute is 1, packets are sent during every monitor cycle.</p> <p>If the value of the attribute is 0, packets are never sent during a monitor cycle. Do not set the value of this attribute to 0 when its corresponding IPMultiNICB resource's IgnoreMultiNICBFailure attribute has a value of 1.</p> <p>Value of this attribute has no effect when IgnoreLinkStatus attribute is set to 1. In such scenario, packets are sent during every monitor cycle to determine the state of an interface.</p> <p>Type and dimension: integer-scalar</p> <p>Default: 1</p> <p>Example: "3"</p> <p>In this example, if monitor entry-point invoking is numbered as 1, 2, 3, 4, 5, 6, ..., the actual packet send test is done at 3, 6, etc. monitor agent functions. For LinkTestRatio=4, the packet send test is done at 4, 8, etc., monitor agent functions.</p>

**Table 3-13** Optional attributes for Base mode (*continued*)

Optional attribute	Description
NetworkHosts	<p>List of host IP addresses on the IP subnet that are pinged to determine if the interfaces work. NetworkHosts only accepts IP addresses to avoid DNS lookup delays. The IP addresses must be directly present on the IP subnet of interfaces (the hosts must respond to ARP requests).</p> <p>If IP addresses are not provided, the hosts are automatically determined by sending a broadcast ping (unless the NoBroadcast attribute is set to 1). The first host to reply serves as the ping destination.</p> <p>Type and dimension: string-vector</p> <p>Example: "192.1.0.1"</p>
NetworkTimeout	<p>Timeout for ARP and ICMP packets in milliseconds. MultiNICB waits for response to ICMP and ARP packets only during this time period.</p> <p>Assign NetworkTimeout a value in the order of tens of milliseconds (given the ICMP and ARP destinations are required to be on the local network). Increasing this value increases the time for failover.</p> <p>Type and dimension: integer-scalar</p> <p>Default: 100</p>
NoBroadcast	<p>If the value of the attribute is 1, NoBroadcast prevents MultiNICB from sending broadcast ICMP packets. Note that MultiNICB can still send ARP requests.</p> <p>If NetworkHosts are not specified and NoBroadcast is set to 1, the MultiNICB agent cannot function properly.</p> <p><b>Note:</b> Symantec Corporation does not recommend setting the value of NoBroadcast to 1.</p> <p>Type and dimension: integer-scalar</p> <p>Default: 0</p>

**Table 3-13** Optional attributes for Base mode (*continued*)

Optional attribute	Description
OfflineTestRepeatCount	<p>Number of times the test is repeated if the interface status changes from UP to DOWN. For every repetition of the test, the next NetworkHost is selected in round-robin manner. At the end of this process, broadcast is performed if NoBroadcast is set to 0. A greater value prevents spurious changes, but also increases the response time.</p> <p>Type and dimension: integer-scalar</p> <p>Default: 3</p>
OnlineTestRepeatCount	<p>Number of times the test is repeated if the interface status changes from DOWN to UP. This test helps to avoid oscillations in the status of the interface.</p> <p>Type and dimension: integer-scalar</p> <p>Default: 3</p>

## Optional attributes for Multi-pathing mode for MultiNICB agent

**Table 3-14** Optional attributes for Multi-pathing mode

Optional attribute	Description
ConfigCheck	<p>If the value of the attribute is 1, the MultiNICB agent checks for:</p> <ul style="list-style-type: none"> <li>■ All specified physical interfaces are in the same IP subnet and group, and have "DEPRECATED" and "NOFAILOVER" flags set on them.</li> <li>■ No other physical interface has the same subnet as the specified interfaces.</li> </ul> <p>If the value of the attribute is 1, the MultiNICB agent also assigns all the specified interfaces in one multi-pathing group.</p> <p>Valid values for this attribute are 0 and 1.</p> <p>Type and dimension: integer-scalar</p> <p>Default: 1</p>

**Table 3-14** Optional attributes for Multi-pathing mode (*continued*)

Optional attribute	Description
MpathdRestart	<p>If the value of the attribute is 1, MultiNICB tries to restart mpathd.</p> <p>Valid values for this attribute are 0 and 1.</p> <p>Type and dimension: integer-scalar</p> <p>Default: 1</p>

## Resource type definition for MultiNICB agent

The resource definition for this agent on Solaris follows:

```

type MultiNICB (
    static int MonitorInterval = 10
    static int OfflineMonitorInterval = 60
    static str Operations = None
    static str ArgList[] = { UseMpathd, MpathdCommand, ConfigCheck,
    MpathdRestart, Device, NetworkHosts, LinkTestRatio,
    IgnoreLinkStatus, NetworkTimeout, OnlineTestRepeatCount,
    OfflineTestRepeatCount, NoBroadcast, DefaultRouter, Failback,
    GroupName, Protocol, IPMPDevice }
    int UseMpathd
    str MpathdCommand = "/usr/lib/inet/in.mpathd"
    int ConfigCheck = 1
    int MpathdRestart = 1
    str Device{}
    str NetworkHosts[]
    int LinkTestRatio = 1
    int IgnoreLinkStatus = 1
    int NetworkTimeout = 100
    int OnlineTestRepeatCount = 3
    int OfflineTestRepeatCount = 3
    int NoBroadcast
    str DefaultRouter = "0.0.0.0"
    int Failback
    str GroupName
    str Protocol = IPv4
    str IPMPDevice
)

```

## Solaris operating modes: Base and Multi-Pathing for MultiNICB agent

The MultiNICB agent has two modes of operation, Base and Multi-Pathing, which you can set with the UseMpathd attribute.

---

**Note:** On Oracle Solaris 11, Multi-Pathing mode is supported only for MultiNICB agent.

---

### Base mode for MultiNICB agent

The value of the UseMpathd attribute is 0 by default for this mode.

In Base mode, to monitor the interfaces that it controls, the agent:

- sends the packets to other hosts on the network for probe-based detection
- tests the link status of the interfaces for link-based detection
- checks that all the specified interfaces are in the same IP subnet and group, and have "NOFAILOVER" and "DEPRECATED" flags set on them
- checks that no other physical interface has the same subnet as the specified interfaces
- assigns all the specified interfaces in one multi-pathing group

The agent logs link failures and failovers when it uses either link- or probe-based detection.

If a NIC goes down, the MultiNICB agent notifies the IPMultiNICB agent. The IPMultiNICB agent fails over the virtual IP addresses to a different NIC on the same system. When the original NIC comes up, the agents fail back the virtual IP address if the Failback attribute for the corresponding MultiNICB resource is set to 1.

Each NIC must have its own unique and exclusive base IP address, which the MultiNICB agent uses as the test IP address.

The MultiNICB agent, in Base mode, uses the following criteria to determine if an interface works:

- Link-based detection of the interface status  
The interface driver reports the status of the link. Note that not all drivers support this feature. Set the value of IgnoreLinkStatus to 1 to disable this test.
- Probe-based detection using Internet Control Message Protocol (ICMP) echo  
Set the LinkTestRatio attribute to a value greater than 0 to send ICMP echo request packets to a specified network host. You specify the network hosts in the NetworkHosts attribute. You must assign test IP addresses to the interface for probe-based detection. The test IP address is needed to send the ICMP

packets, which determines the link's status. If you set the value of the `LinkTestRatio` attribute to 0, you do not need to assign test IP addresses.

If you specify no hosts in the `NetworkHosts` attribute, the agent uses the ICMP broadcast when the value of the `NoBroadcast` attribute is 0. It caches the sender of the first reply for future use as a network host. While the agent sends and receives ICMP packets, the IP layer is completely bypassed.

You can assign addresses and still do only link-based detection by setting the values of the `LinkTestRatio` attribute to greater than 0 and the `IgnoreLinkStatus` attribute to 0.

You can skip link-based detection (link driver tests) and only do ICMP tests if:

- the value of the `IgnoreLinkStatus` attribute is 1, and
- the value of the `LimitTestRation` attribute is greater than 0, and
- the test IP addresses are assigned to the interface

The MultiNICB agent performs both link-based detection and probe-based detection if:

- the value of the `LinkTestRatio` attribute is greater than 0, and
- the value of the `IgnoreLinkStatus` attribute is 0, and
- the test IP addresses are assigned to the interface

The MultiNICB agent writes the status of each interface to an export information file, which other agents (like IPMultiNICB) or commands (like `haipswitch`) can read.

## Failover and failback for MultiNICB agent

During an interface failure, the MultiNICB agent fails over all logical IP addresses to a working interface under the same resource. The agent remembers the first physical interface from which an IP address was failed over. This physical interface becomes the "original" interface for the particular logical IP address. When the original interface is repaired, the logical IP address fails back to it.

## Multi-Pathing mode for MultiNICB agent

To activate this mode set the value of the `UseMpathd` attribute to 1. The MultiNICB agent, in Multi-Pathing mode, monitors Oracle's IP Multi-Pathing daemon (`mpathd`). The MultiNICB agent specifically monitors the `FAILED` flag on physical interfaces and the `mpathd` process. See the man page: `in.mpathd (1M)` for more information on this daemon.

Oracle's mpathd daemon monitors the interfaces that are part of the IPMP group. The daemon:

- sends the packets to other hosts on the network for probe-based detection as long as a test IP address is assigned to the network interface
- checks the link status of the interfaces for link-based detection as long as the interface supports the test for detection

The mpathd daemon can perform both link- and probe-based detection when test IP addresses are assigned to NIC interfaces.

The MultiNICB agent logs errors when the daemon is not running, or if a configuration path error exits. The mpathd daemon logs link failures and IP address failovers in the system log.

## Configuring MultiNICB and IPMultiNICB agents on Solaris 11

On Solaris 11 you must configure IPMultiNICB and MultiNICB resources as follows:

1. Create an IPMP interface manually for the interfaces under MultiNICB control.  
For more information, refer to *Oracle Solaris Administration: Network interfaces and Network Virtualization Guide*.
2. Specify the IPMP interface name as the IPMPDevice attribute value of the MultiNICB resource.
3. Set the UseMpathd and ConfigCheck attribute values of the MultiNICB resource to 1 and 0 respectively.
4. Ensure that the IPMP interface and corresponding base interfaces are configured correctly and are up before enabling the MultiNICB resource.

## Trigger script for MultiNICB agent

MultiNICB monitor agent function calls a VCS trigger in case of an interface going up or down.

The agent passes the following arguments to the script:

- MultiNICB resource name
- The device whose status changed, for example:
  - qfe0
- The device's previous status (0 for down, 1 for up)
- The device's current status and monitor heartbeat

The agent also sends a notification (which may be received via SNMP or SMTP) to indicate that status of an interface changed. The notification is sent using "health of a cluster resource declined" and "health of a cluster resource improved" traps. These traps are mentioned in the *Veritas Cluster Server Administrator's Guide*. A sample `mnicb_postchange` trigger is provided with the agent. You can customize this sample script as needed or write one from scratch.

The sample script does the following:

- If interface changes status, it prints a message to the console, for example:

```
MultiNICB: Interface qfe0 came up
```

- The script saves last IP address-to-interface name association. If any of the IP addresses have been moved, added, or removed, it prints out a message to the console, for example:

```
MultiNICB: IP address 192.4.3.3 moved from interface  
qfe1:1 to interface qfe0:1
```

## Sample configurations for MultiNICB agent

### Interface configuration for MultiNICB agent on Solaris

Set the `EPROM` variable to assign unique MAC addresses to all ethernet interfaces on the host:

```
# eeprom local-mac-address?=true
```

Reboot the system after setting the `eprom` variable to complete the address setup. The base IP addresses must be configured on the interfaces before the MultiNICB agent controls the interfaces. You can configure these addresses at system start up using `/etc/hostname.XXX` initialization files. Refer to the following examples for more information.

### Setting up test IP addresses for Base Mode

These examples demonstrate setting up test IP addresses for your clustered systems. These IP addresses allow the agent determine if the NIC works. The agent determines that the NIC works if it receives responses for the ping packets that it sends to other nodes on the network. You do not need to perform the following steps for the floating IP addresses. The agent performs these steps.

In the file `/etc/hostname.qfe0`, add the following two lines:



```
north-qfe0 netmask + broadcast + deprecated -failover up \
    addif north netmask + broadcast + up
```

Where north-qfe0 is the test IP address that the agent uses to determine the state of the qfe0 network card.

In the file /etc/hostname.qfe4, add the following line:

```
north-qfe4 netmask + broadcast + deprecated -failover up
```

Where north-qfe4 is the test IP address that the agent uses to determine the state of the qfe4 network card.

In the example, north-qfe0 and north-qfe4 are the host names that correspond to test IP addresses. north is the host name that corresponds to the test IP address.

## IPMultiNICB and MultiNICB configuration for MultiNICB agent

The following is an example IPMultiNICB and MultiNICB configuration:

```
cluster clus_north (
  UserNames = { admin = "cDRpdxPmHpzS." }
  Administrators = { admin }
  CounterInterval = 5
)
system north (
)
system south (
)
group g11 (
  SystemList = { north = 0, south = 1 }
  AutoStartList = { north, south }
)
IPMultiNICB g11_i1 (
  BaseResName = gnic_n
  Address = "192.1.0.201"
  NetMask = "255.255.0.0"
  DeviceChoice = "1"
)
Proxy g11_p1 (
  TargetResName = gnic_n
)
g11_i1 requires g11_p1
// A parallel group for the MultiNICB resource
group gnic (
  SystemList = { north = 0, south = 1 }
```

```
AutoStartList = { north, south }
Parallel = 1
)
MultiNICB gnic_n (
Device @north = { qfe0 = 0, qfe4 = 1 }
Device @south = { qfe0 = 0, qfe4 = 1 }
NetworkHosts = { "192.1.0.1" }
)
Phantom gnic_p (
)
```

## IPv6 configuration for MultiNICB agent

The following is a basic configuration for IPv6 with IPMultiNICB and MultiNICB resources for Oracle Solaris 10.

```
group multinicb_grp (
    SystemList = { sysA = 0, sysB = 1 }
)

    IPMultiNICB ip_res (
        BaseResName = nic_res
        Address = "3ffe:21::90:1211:161"
        PrefixLen = 64
    )

    MultiNICB nic_res (
        Device = { e1000g1 = 0, e1000g3 = 1 }
        Failback = 1
        Protocol = IPV6
    )

    ip_res requires nic_res
```

The following is a basic configuration for IPv6 with IPMultiNICB and MultiNICB resources for Oracle Solaris 11.

```
group mnichb_grp (
    SystemList = { sysA = 0, sysB = 1 }
)

    IPMultiNICB ipmnichb (
        BaseResName = mnichb
```

```
Address = "192.168.1.10"  
NetMask = "255.255.0.0"  
)
```

```
MultiNICB mnicb (  
  UseMpathd = 1  
  ConfigCheck = 0  
  Device = { net1 = 0, net2 = 1 }  
  NetworkHosts = { "192.168.1.1" }  
  IPMPDevice = ipmp0  
)
```

ipmnicb requires mnicb

## Debug log levels for MultiNICB agent

The MultiNICB agent uses the following debug log levels:

DBG\_1, DBG\_2, DBG\_3, DBG\_4, DBG\_5

## DNS agent

The DNS agent updates and monitors the mapping for the following:

- The host name to IP address (A, AAAA, or PTR record)
- Alias to hostname or canonical name (CNAME)

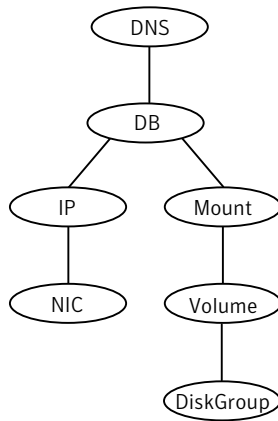
The agent performs these tasks for a DNS zone when failing over nodes across subnets (a wide-area failover). Resource records (RR) can include different types: A, AAAA, CNAME, and PTR records.

Use the DNS agent if the Resource Records need to be dynamically added and deleted from the DNS servers during failover. The agent updates the name server with the new resource record mappings while failing over and allows the clients to connect to the failed over instance of the application.

For important information about this agent, refer to [Agent notes for DNS agent](#)

## Dependencies for DNS agent

No dependencies exist for the DNS resource.

**Figure 3-7** Sample service group that includes a DNS resource

## Agent functions for DNS agent

Online	<p>Updates one or more name servers with the resource records.</p> <p>The agent updates the name servers defined in the StealthMasters attribute. If you have not configured this attribute then the agent obtains the name of the master server by sending an Start of Authority (SOA) query. This query retrieves the SOA record of the zone defined in the agent's Domain attribute. This SOA record contains the name of the master server.</p> <p>The agent creates PTR records for each RR of type A or AAAA if the value of the CreatePTR attribute is true. A prerequisite for this feature is that the same master or stealth server serves the forward (A or AAAA) and reverse zones.</p> <p>Finally the agent generates an Online lock file to indicate that the resource is online on the current system.</p> <p><b>Note:</b> The DNS agent does not send any update for a resource record if it is already present on the name server.</p>
Offline	<p>Removes the Online lock file.</p> <p>If attribute OffDelRR is true, offline removes all records that the ResRecord keys define.</p>

Monitor	<p>Returns the ONLINE state if at least one name server reports all mappings that ResRecord defines. The name servers are the master or StealthMaster servers and all the servers for which an NS record for the zone exists.</p> <p>The monitor entry point also sends periodic refresh requests to DNS server if the RefreshInterval attribute is set.</p>
Clean	<p>Removes the Online lock file, if it exists. If attribute OffDeIRR is true, clean removes all records that the ResRecord keys define.</p>
Open	<p>Removes the Online lock file if the resource is reported online on another node inside the cluster to prevent concurrency violation. If the lock file exists, at least one name server has to report all the records that the ResRecord attribute defines. If all the name servers fail to report all the records, the agent function removes the Online lock file.</p>
Action	<p>Different action agent functions follow:</p> <ul style="list-style-type: none"><li>■ keyfile.vfd This action entry point checks if the key file as specified in the TSIGKeyFile attribute exists either locally or on shared storage.</li><li>■ dig.vfd This action entry point checks if dig and nsupdate binaries exist and are executable.</li><li>■ master.vfd This action entry point checks if stealth masters are able to reply to SOA query for the configured domain.</li></ul>

## State definitions for DNS agent

The state definitions for this agent follow:

ONLINE	<p>Online lock file exists and at least one name server can return all configured resource records.</p>
OFFLINE	<p>At least one of the following is true:</p> <ul style="list-style-type: none"><li>■ The online lock does not exist.</li><li>■ None of the name servers can report all of the RRs' mappings.</li></ul>
UNKNOWN	<p>Indicates that the DNS resource is not configured correctly. Can indicate that the resource record list contains an invalid value as a part of the record key or a record value of the ResRecord attribute.</p>

## Attributes for DNS agent

**Table 3-15** Required attributes

Required attribute	Description
Domain	<p>A string representing the DNS zone that the agent administers.</p> <p>The domain name can only contain alphanumeric symbols and the dash.</p> <p>Type and dimension: string-scalar</p> <p>Examples:</p> <ul style="list-style-type: none"><li>■ Forward mapping: "demo.example.com"</li><li>■ IPv4 reverse mapping: "2.168.192.in-addr.arpa"</li></ul>

**Table 3-15** Required attributes (*continued*)

Required attribute	Description
ResRecord	

**Table 3-15** Required attributes (*continued*)

Required attribute	Description
	<p>ResRecord is an association of DNS resource record values. Each ResRecord attribute consists of two values: <i>DNS record key = DNS record data</i>. Note that the record key must be a unique value.</p> <p>If the resource record list contains any invalid value as a part of the record key or a record data of the ResRecord attribute, the resource reports an UNKNOWN state.</p> <p>Type and dimension: string-association</p> <p>Examples:</p> <ul style="list-style-type: none"> <li>■ For forward mapping, where the zone is demo.example.com: <ul style="list-style-type: none"> <li>- sol901 = "192.168.2.191"</li> <li>- ww2 = sol901</li> <li>- sol9ip6 = "2007::1:2:3:abc"</li> </ul> </li> <li>■ For a multi-home DNS record, typically for one host with two network interfaces and different addresses, but the same DNS name. The A type ResRecord configuration should be as follows: <ul style="list-style-type: none"> <li>sol902 = "192.168.2.102 10.87.13.22"</li> </ul> A multi-home AAAA DNS record can be configured as follows: <ul style="list-style-type: none"> <li>sol902 = "1234::5678 1234::AABB:CCDD"</li> </ul> </li> <li>■ For reverse IPv4 address mapping, where the zone is 2.168.192.in-addr.arpa: <ul style="list-style-type: none"> <li>191 = "sol901.demo.example.com"</li> </ul> </li> <li>■ For reverse IPv6 address mapping, where the zone is 3.0.0.0.2.0.0.0.1.0.0.0.0.0.0.0.0.0.0.0.0.0.0.0.0.7.0.0.2.ip6.arpa: <ul style="list-style-type: none"> <li>cba = "sol9ip6.demo.example.com"</li> </ul> </li> </ul> <p>Use only partial host names. If you use a fully qualified domain name, append a period "." at the end of the name.</p> <p>For CNAME records, use:</p> <ul style="list-style-type: none"> <li>■ ResRecord = { www = mydesktop }</li> <li>or</li> <li>■ ResRecord = { www = "mydesktop.marketing.example.com." }</li> </ul> <p>Where the Domain attribute is "marketing.example.com"</p> <p>The agent uses case-insensitive pattern matching—and a combination of the Domain and ResRecord attribute values—to determine the resource record type. The RR types are as</p>



**Table 3-15** Required attributes (*continued*)

Required attribute	Description
	<p>follows:</p> <ul style="list-style-type: none"> <li>■ PTR: if the Domain attribute ends with .arpa</li> <li>■ A: if the record data field is an IPv4 address (four sets of numbers, where a period separates each set. The following details the pattern it tries to match:  [1-223].[0-255].[0-255].[0-255] Hexadecimal is not supported.)</li> <li>■ AAAA: if the record data fields are in multiple sets of hexadecimal format, then this record is an IPv6 associated type AAAA record.</li> <li>■ CNAME: for any other valid record data.</li> </ul> <p><b>Note:</b> If a name in the ResRecord attribute does not comply with RFC 1035, then the agent logs a warning message to the engine log file. This ResRecord association is not used. As an exception to this, the DNS agent allows underscore character ("_") in hostnames. Make sure that the DNS server supports the underscore character before you configure any DNS resource records to have the underscore character in their hostnames.</p>

**Table 3-16** Optional attributes

Optional attribute	Description
TTL	<p>This attribute (a non-zero integer) represents the Time To Live (TTL) value, in seconds, for the DNS entries in the zone that you want to update.</p> <p>A lower value means more hits on your DNS server, while a higher value means more time for your clients to learn about changes.</p> <p>The TTL may take the value 0, which indicates never caching the record, to a maximum of 2,147,483,647, which is over 68 years! The current best practice recommendation (RFC 1912) proposes a value greater than one day, and on RRs that do not change often, consider multi-week values.</p> <p>Type and dimension: integer-scalar</p> <p>Default: 86400</p> <p>Example: 3600</p>

**Table 3-16** Optional attributes (*continued*)

Optional attribute	Description
StealthMasters	<p>The list of primary master name servers in the domain.</p> <p>This attribute is optional since the first name server is retrieved from the zone's SOA (Start of Authority) record.</p> <p>If the primary master name server is a stealth server, define this attribute. A stealth server is a name server that is authoritative for a zone, but does not appear in that zone's SOA record. It is hidden to prevent direct attacks from the Internet.</p> <p>Type and dimension: string-vector</p> <p>Example: { "10.190.112.23" }</p>
TSIGKeyFile	<p>Required when you configure DNS for secure updates. Specifies the absolute path to the file containing the private TSIG (Transaction Signature) key. This attribute should be configured only when the DNS server configured is a Unix based DNS server.</p> <p>Type and dimension: string-scalar</p> <p>Example:</p> <pre>/var/tsig/example.com.+157+00000.private</pre>
CreatePTR	<p>Use the CreatePTR attribute to direct the online agent functions to create PTR records for each RR of type A or AAAA. You must set the value of this attribute to true (1) to create the records. Before you can use this attribute, make sure that the same master or stealth servers serve the forward (A or AAAA) and reverse zones.</p> <p>Type and dimension: boolean-scalar</p> <p>Default: 0</p> <p>Example: 1</p>
OffDelRR	<p>Use the OffDelRR attribute to direct the offline and clean agent functions to remove all records that the ResRecord key defines. You must set the value of this attribute to 1 (true) to have the agent remove all the records.</p> <p>Type and dimension: boolean-scalar</p> <p>Default: 0</p> <p>Example: 1</p>

**Table 3-16** Optional attributes (*continued*)

Optional attribute	Description
UseGSSAPI	<p>Use the UseGSSAPI attribute if the DNS server that you have configured is a Windows DNS server and only if it accepts secure dynamic updates.</p> <p><b>Note:</b> Do not set this attribute if the Windows DNS server accepts non-secure updates.</p> <p>If this attribute is set to 1, the agent uses the -g option with the nsupdate command.</p> <p>See <a href="#">"Agent notes for DNS agent"</a> on page 140. for more information on requirements to use the DNS agent with the secure Windows DNS server.</p> <p>Type and dimension: boolean-scalar</p> <p>Default: 0</p> <p>Example: 1</p>
RefreshInterval	<p>This attribute represents the time interval in seconds after which the DNS agent attempts to refresh the resource records (RRs) on the DNS servers. The default value of zero indicates that the DNS agent does not attempt to refresh the records on the DNS servers. The DNS agent writes the warning message to the logs if it is not able to refresh the DNS records.</p> <p><b>Note:</b> The refresh request is sent in the next monitor cycle after the RefreshInterval period is reached.</p> <p>If the DNS agent is unable to refresh the DNS records, and the records are removed as a result of a scavenging operation or by the DNS administrator, the DNS resource will fault.</p> <p>Type and dimension: integer-scalar</p> <p>Default: 0</p> <p>Example: 3600</p>

**Table 3-16** Optional attributes (*continued*)

Optional attribute	Description
CleanRRKeys	<p>Use this attribute to direct the online agent function to clean up all the existing DNS records for the configured keys before adding new records. The default value (0) disables this behavior.</p> <p><b>Note:</b> If multiple DNS resources are configured with the same key value in their ResRecord attribute, then do not set this attribute value to 1.</p> <p>Type and dimension: boolean-scalar</p> <p>Default: 0</p> <p>Example: 1</p>

## Resource type definition for DNS agent

The resource definition for this agent on Solaris follows:

```

type DNS (
    static keylist SupportedActions = { "dig.vfd",
    "master.vfd", "keyfile.vfd" }
    static str ArgList[] = { Domain, TTL, TSIGKeyFile,
    StealthMasters, ResRecord, CreatePTR, OffDelRR,
    UseGSSAPI, RefreshInterval, CleanRRKeys }
    str Domain
    int TTL = 86400
    str TSIGKeyFile
    str StealthMasters[]
    str ResRecord{}
    boolean CreatePTR = 0
    boolean OffDelRR = 0
    boolean UseGSSAPI = 0
    int RefreshInterval = 0
    boolean CleanRRKeys = 0
)

```

## Agent notes for DNS agent

The DNS agent has the following notes:

- [About using the VCS DNS agent on UNIX with a secure Windows DNS server](#)
- [High availability fire drill for DNS agent](#)

- [Monitor scenarios for DNS agent](#)
- [Sample Web server configuration for DNS agent](#)
- [Secure DNS update for BIND 9 for DNS agent](#)
- [Setting up secure updates using TSIG keys for BIND 9 for DNS agent](#)

## About using the VCS DNS agent on UNIX with a secure Windows DNS server

This section describes the requirements for using the DNS agent with a secure Windows DNS server. Note that there are no special requirements for sending non-secure updates to a Windows DNS server.

### Software requirement for DNS agent

For the secure updates on Windows DNS server to work, the VCS DNS agent on UNIX requires BIND version 9.7.2-P3 or later installed on all cluster nodes.

### Configuration requirement for DNS agent

The VCS DNS agent on UNIX requires setting up Kerberos authentication with the Windows DNS server and configuring the domain and DNS server information in `/etc/resolv.conf` at the client node.

To set up the Kerberos authentication from the UNIX host to the Windows DNS server, configure the Kerberos configuration file (`/etc/krb5.conf` or `/etc/krb/krb5.conf`) to use the Windows DNS server as Key Distribution Centre (KDC).

A sample Kerberos configuration file with domain `privdns.sym` and DNS server `master.privdns.sym` is as follows:

```
[libdefaults]
default_realm = PRIVDNS.SYM
dns_lookup_realm = true
dns_lookup_kdc = true
default_tkt_enctypes = des-cbc-md5
default_tgs_enctypes = des-cbc-md5
ticket_lifetime = 24h
renew_lifetime = 7d
forwardable = true
allow_weak_crypto = true
[realms]
PRIVDNS.SYM = {
kdc = master.privdns.sym:88
kpasswd_server = master.privdns.sym:464
admin_server = master.privdns.sym
```

```
}  
[domain_realm]  
.privdns.sym = PRIVDNS.SYM  
privdns.sym = PRIVDNS.SYM
```

---

**Note:** Symantec does not support KDC and Domain Controller/DNS located on different servers.

---

Authenticate all the nodes on the cluster (on which the DNS agent is configured to run) with the Active directory. Use kinit on your user account and use klist to verify that you have a ticket to the configured realm principal. Refer to the man page of kinit for more information on obtaining Kerberos ticket granting tickets from KDC.

---

**Note:** The DNS agent requires a node to be authenticated with Kerberos all the time. Renew the obtained tickets periodically if your authentication method requires you to do so.

---

A sample run of kinit and klist for the above configuration with user vcsdns will look as follows:

```
# kinit vcsdns  
Password for vcsdns@PRIVDNS.SYM:  
# klist  
Ticket cache: FILE:/tmp/krb5cc_0  
Default principal: vcsdns@PRIVDNS.SYM  
Valid starting Expires Service principal  
12/14/09 16:17:37 12/15/09 02:19:09 krbtgt/PRIVDNS.SYM@PRIVDNS.SYM  
renew until 12/21/09 16:17:37
```

If the environment variable KRB5CCNAME is set to some non-default location (default is /tmp), then VCS will not inherit it by default and will look for the Kerberos tickets in default location /tmp.

To resolve this issue, un-set the environment variable KRB5CCNAME and run the kinit command again. This will update the Kerberos tickets in default location (/tmp). Else, for a customized location (for example, /cache/krb\_ticket) for Kerberos tickets, add an entry in opt/VRTSvcs/bin/vcsenv file on each cluster node before VCS starts:

```
KRB5CCNAME="FILE:/cache/krb_ticket"  
export KRB5CCNAME
```

Update `/etc/resolv.conf` on your client node to add information for the Windows DNS server and the configured domain.

## High availability fire drill for DNS agent

The high availability fire drill detects discrepancies between the VCS configuration and the underlying infrastructure on a node; discrepancies that might prevent a service group from going online on a specific node.

For DNS resources, the high availability drill tests the following conditions:

- Checks if the key file as specified by the `TSIGKeyFile` attribute is available either locally or on shared storage.
- Checks if the `dig` and `nsupdate` binaries are available on the cluster node and are executable on that node.
- Checks if the stealth masters can respond to the SOA query made from the cluster node so as to ensure that there is no network issue that would prohibit the DNS update and query requests from reaching the stealth master server.

For more information about using the high availability fire drill see the *Veritas Cluster Server Administrator's Guide*.

## Monitor scenarios for DNS agent

Depending on the existence of the Online lock file and the defined Resource Records (RR), you get different status messages from the Monitor function.

[Table 3-17](#) summarizes the monitor scenarios for the Online lock files.

**Table 3-17** Monitor scenarios for the Online lock file

Online lock file exists	Expected RR mapping	Monitor returns
NO	N/A	OFFLINE
YES	NO	OFFLINE
YES	YES	ONLINE

## Sample Web server configuration for DNS agent

Take the example of a Web server. A browser requests the URL `http://www.example.com` that maps to the canonical name `server1.example.com`. The browser retrieves the IP address for the web server by querying a domain name server. If the web server fails over from server one to server two (`server2.example.com`), the domain name servers need a new canonical name

mapping for `www.example.com`. After the failover, the DNS resource updates this mapping of `www.example.com` to point to canonical name `server2.example.com`

---

**Note:** In this configuration, the Domain attribute should be configured with value `"example.com"`

---

## Secure DNS update for BIND 9 for DNS agent

The DNS agent expects that the zone's `allow-update` field contains the IP address for the hosts that can dynamically update the DNS records. This functionality is default for the DNS agent. Since a competent black hat can, however, spoof IP addresses, consider TSIG as an alternative.

TSIG (Transaction Signature) as specified in RFC 2845 is a shared key message authentication mechanism that is available in BIND DNS. A TSIG key provides the means to authenticate and verify the validity of exchanged DNS data. It uses a shared secret key between a resolver and either one or two servers to provide security.

## Setting up secure updates using TSIG keys for BIND 9 for DNS agent

In the following example, the domain is `example.com`.

To use secure updates using TSIG keys, perform the following steps at the DNS server:

- 1 Run the `dnssec-keygen` command with the HMAC-MD5 option to generate a pair of files that contain the TSIG key:

```
# dnssec-keygen -a HMAC-MD5 -b 128 -n HOST example.com.
```

- 2 Open the `example.com.+157+00000.key` file. After you run the `cat` command, the contents of the file resembles:

```
# cat example.com.+157+00000.key
example.com. IN KEY 512 3 157 +Cdjlkef9ZTSeixERZ433Q==
```

- 3 Copy the shared secret (the TSIG key), which looks like:

```
+Cdjlkef9ZTSeixERZ433Q==
```



- 4 Configure the DNS server to only allow TSIG updates using the generated key. Open the `named.conf` file and add these lines.

```
key example.com. {  
    algorithm hmac-md5;  
    secret "+Cdjlkef9ZTSeixERZ433Q==";  
};
```

Where `+Cdjlkef9ZTSeixERZ433Q==` is the key.

- 5 In the `named.conf` file, edit the appropriate zone section and add the `allow-update` sub-statement to reference the key:

```
allow-update { key example.com. ; } ;
```

- 6 Save and restart the `named` process.
- 7 Place the files containing the keys on each of the nodes that are listed in your group's `SystemList`. The DNS agent uses this key to update the name server. Copy both the private and public key files on to the node. A good location is in the `/var/tsig/` directory.
- 8 Set the `TSIGKeyFile` attribute for the DNS resource to specify the file containing the private key.

```
DNS www (  
    Domain = "example.com"  
    ResRecord = {www = north}  
    TSIGKeyFile = "/var/tsig/example.com.+157+00000.private"  
)
```

## Sample configurations for DNS agent

This section contains sample configurations for this agent.

### Basic IPv6 configuration for DNS agent

This sample configuration provides basic configuration for IPv6 support. In the following configuration, `nic_value` represents the base NIC value for the platform

For example: `e1000g0`

```
group ipv6_group_dns (  
    SystemList = { sysA = 0, sysB = 1 }  
)
```

```
DNS ipv6group_dns_res (
    Critical = 0
    Domain = "example.com"
    TSIGKeyFile = "/var/tsig/Kipv6.vcsd.net.+157+18435.private"
    StealthMasters = { "2001:db8:c18:2:69c4:3251:bac1:6cbe" }
    ResRecord = {
        vcssystemCv6 = "2001:db8:c18:2:214:4fff:fe96:8833",
        sysC = vcssystemCv6 }
    )

IP ipv6group_ip_res (
    Device @sysA = nic_value
    Device @sysB = nic_value
    Address = "2001:db8:c18:2:214:4fff:fe96:8833"
    PrefixLen = 64
    )

NIC ipv6group_nic_res (
    Device @sysA = nic_value
    Device @sysB = nic_value
    NetworkHosts = { "2001:db8:c18:2:214:4fff:fea2:fd50" }

Protocol = IPv6

)

ipv6group_dns_res requires ipv6group_ip_res
ipv6group_ip_res requires ipv6group_nic_res
```

## IPv6 CNAME sample configuration for DNS agent

The following sample configuration uses CNAME values.

```
group cname_group (
    SystemList = { sysA = 0, sysB = 1 }
    )

DNS cname_group_dns_res (
    Domain = "example.com"
    StealthMasters = { "3ffe:556::1000:5761" }
    ResRecord @sysA = { www = server1 }
    ResRecord @sysB = { www = server2 }
```

```
        OffDelRR = 1
    )
```

## IPv4 A sample configuration for DNS agent

The following sample configuration uses A values.

```
group forwardv4_group (
    SystemList = { sysA = 0, sysB = 1 }
)

DNS forward_group_v4_resource (
    Domain = "example.com"
    StealthMasters = { "3ffe:556::1000:5761" }
    ResRecord @sysA = { www = "10.200.56.240" }
    ResRecord @sysB = { www = "10.200.56.244" }
    OffDelRR = 1
)
```

## Debug log levels for DNS agent

The DNS agent uses the following debug log levels:

DBG\_1, DBG\_2, DBG\_3, DBG\_4, DBG\_5

# File share agents

This chapter includes the following topics:

- [About the file service agents](#)
- [NFS agent](#)
- [NFSRestart agent](#)
- [Share agent](#)
- [About the Samba agents](#)
- [SambaServer agent](#)
- [SambaShare agent](#)
- [NetBios agent](#)

## About the file service agents

Use the file service agents to provide high availability for file share resources.

## NFS agent

Starts and monitors the `nfsd` and `mountd` daemons required by all exported NFS file systems.

You should configure only a single NFS resource in a service group on a node. If you have more than one service group that uses the NFS resource, the other service groups must use a Proxy resource. The Proxy resource can point to the NFS resource in the first group. Duplicate NFS resources will cause a problem when the NFS resources are brought online concurrently—only the NFS resource started

first will be successfully brought online, while the rest of the NFS resources may report online failure.

---

**Note:** VCS supports a maximum of one service group with NFS shares when the UseSMF attribute's value is 1.

---

**Note:** (Solaris 10, Solaris 11) VCS does not support the resource to use SMF if you set the UseSMF attribute to 0.

---

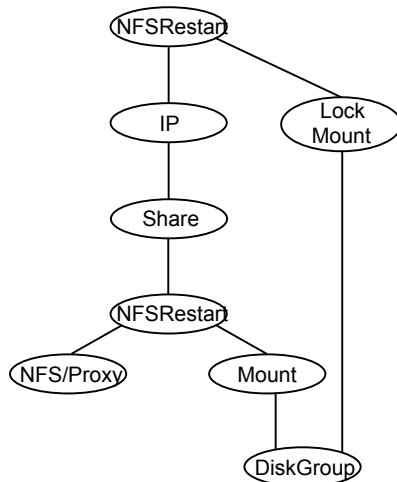
For important information about this agent,

See [“Notes for NFS agent”](#) on page 152.

## Dependencies for NFS agent

For more information regarding NFS resource dependencies, refer to the *Veritas Cluster Server Administrator's Guide*.

**Figure 4-1** Sample service group that includes an NFS resource



## Agent functions for NFS agent

Online	Checks if nfsd, mountd, and nfsmapid (nfsmapid is for Solaris 10) daemons are running. If they are not running, the agent starts the daemons.
--------	---

Monitor	Monitors versions 2, 3, and 4 of the nfsd daemons, and versions 1, 2, and 3 of the mountd daemons. Monitors TCP and UDP versions of the daemons by sending RPC (Remote Procedure Call) calls <code>clnt_create</code> and <code>clnt_call</code> to the RPC server. If the calls succeed, the resource is reported ONLINE.
Clean	Terminates and restarts the nfsd, mountd, and nfsmapid daemons.

## State definitions for NFS agent

ONLINE	Indicates that the NFS daemons are running in accordance with the supported protocols and versions.
OFFLINE	Indicates that the NFS daemons are not running in accordance with the supported protocols and versions.
FAULTED	Indicates that the NFS daemons are not running in accordance with the supported protocols and versions.
UNKNOWN	Unable to determine the status of the NFS daemons.

## Attributes for NFS agent

**Table 4-1** Optional attributes for Solaris

Optional attributes	Description
CleanRmtab	To clear the <code>/etc/rmtab</code> file before starting the mount daemon, set the value of CleanRmtab to 1.  Type and dimension: boolean-scalar  Default: 0
LockFileTimeout	Specifies the time period in seconds after which the agent deletes the lock files. The agent maintains the files internally to synchronize the starting and stopping of NFS daemons between multiple service groups.  Set this value to the total time needed for a service group to go offline or come online on a node. In situations where you have multiple service groups, set this value for the service group that takes the longest time.  Type and dimension: integer-scalar  Default: 180  Example: 240

**Table 4-1** Optional attributes for Solaris (*continued*)

Optional attributes	Description
Nservers	<p>Specifies the number of concurrent NFS requests the server can handle.</p> <p>Type and dimension: integer-scalar</p> <p>Default: 16</p> <p>Example: 24</p>
UseSMF	<p>For Solaris 10, the value of this attribute determines whether you want to enable the resource to use Service Management Facility (SMF) for NFS daemons.</p> <p>Set the value of the UseSMF attribute to 1, to enable the resource to use SMF.</p> <p>Accept the default value of 0 if you do not want to enable the resource to use SMF. You must keep the NFS daemons under VCS control however.</p> <p>On Solaris 11, UseSMF must be set to 1.</p> <p><b>Note:</b> On Solaris 10, when you use a SMF service to enable the NFS server, a service issue requires that at least one entry is present in <code>/etc/dfs/dfstab</code>.</p> <p><b>Note:</b> On Solaris 11, when you use a SMF service to enable the NFS server, ensure that there is at least one shared directory present on each node to configure the agent. Use the following command to share a directory across reboots:</p> <pre>#share /xyz</pre> <p>See <a href="#">“Using Service Management Facility (SMF) to control NFS daemons for Solaris 10”</a> on page 152.</p> <p>Type and dimension: boolean-scalar</p> <p>Default: 0</p>

## Resource type definition for NFS agent

```
type NFS (
  static int RestartLimit = 1
  static str ArgList[] = { UseSMF, Nservers, LockFileTimeout,
    CleanRmtab }
  static str Operations = OnOnly
  int Nservers = 16
```

```
int LockFileTimeout = 180
boolean UseSMF = 0
boolean CleanRmtab = 0
)
```

## Notes for NFS agent

The NFS agent has the following notes:

- [Using Service Management Facility \(SMF\) to control NFS daemons for Solaris 10](#)

### Using Service Management Facility (SMF) to control NFS daemons for Solaris 10

On Solaris 10, if you do not want to use SMF for NFS daemon control, disable SMF for these daemons.

SMF use for NFS resources is disabled by default. If you plan to use it for NFS resources, you must set the value of the UseSMF attribute to a value of 1. If you set the value of the UseSMF attribute to 1, you do not have to perform the following instructions. If you keep the default value of 0 for the UseSMF attribute, you must perform the following instructions. UNIX start-up scripts and configuration files previously performed these functions. SMF maintains the Service Configuration Repository to store persistent configuration information as well as runtime data for all the services. All NFS daemons (nfsd, mountd, etc.) are now controlled by SMF. To keep these daemons under VCS control, modify the configuration repository to disable the SMF framework for NFS daemons. You must invoke the following command before bringing the NFS agent online or the agents returns an UNKNOWN state.

#### To keep nfsd and mountd daemons under VCS control

- 1 Set the auto\_enable property to false.

```
# svccfg -s nfs/server setprop "application/auto_enable = false"
```

- 2 Refresh the SMF configuration repository.

```
# svcadm refresh nfs/server
```



### 3 Disable SMF.

```
# svcadm disable svc:/network/nfs/server:default
```

### 4 Run `svcs -a | grep -i nfs` command and review its output to make sure that SMF for `nfsd` and `mountd` is disabled.

```
# svcs -a | grep -i nfs
disabled May_29 svc:/network/nfs/server:default
```

## To keep `nfsmapid` daemon under VCS control

### 1 Set the `auto_enable` property to false.

```
# svccfg -s nfs/mapid setprop "application/auto_enable = false"
```

### 2 Refresh the SMF configuration repository.

```
# svcadm refresh nfs/mapid
```

### 3 Disable SMF.

```
# svcadm disable svc:/network/nfs/mapid:default
```

### 4 Run `svcs -a | grep -i mapid` command and review its output to make sure that SMF for `nfsmapid` is disabled.

```
# svcs -a | grep -i mapid
disabled May_29 svc:/network/nfs/mapid:default
```

## Sample configurations for NFS agent

On each node in your cluster, you can find sample NFS, NFSRestart, and Share configurations in `/etc/VRTSvcs/conf/sample_nfs/`.

For more information regarding agent configuration, refer to the *Veritas Cluster Server Administrator's Guide*.

## Debug log levels for NFS agent

The NFS agent uses the following debug log levels:

DBG\_1, DBG\_3, DBG\_4, DBG\_5

# NFSRestart agent

The NFSRestart agent provides the following functionalities:

Manages essential NFS locking services, network status manager, and lock manager.

Manages NFS lock recovery service by recovering the NFS record locks after sudden server crash.

Prevents potential NFS ACK storms by terminating NFS server services before offline of NFS VIP to close all TCP connections with the NFS client.

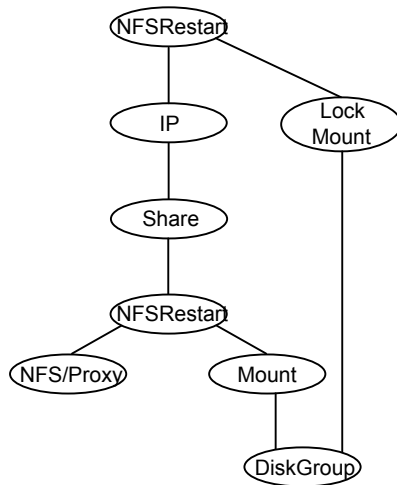
If you have configured the NFSRestart agent for lock recovery, the NFSRestart agent starts the smsyncd daemon. The daemon copies the NFS locks from the local directory `/var/statmon/sm` to shared storage. The agent's online function copies the locks from shared storage to local directory `/var/statmon/sm`.

For important information about this agent, refer to [Notes for NFSRestart agent](#)

## Dependencies for NFSRestart agent

For more information regarding NFSRestart resource dependencies, refer to the *Veritas Cluster Server Administrator's Guide*.

You must use two NFSRestart resources in a service group. Both the NFSRestart resources provide combined protection from potential corruption of NFS locks and potential NFS ACK storms. The lower NFSRestart resource must have its Lower attribute set to 1. The upper NFSRestart resource should be at the top of the resource dependency tree and the lower NFSRestart resource should be below the Share resource in the resource dependency tree. The NFSRestart resources and the Share resources must be inside the same service group.

**Figure 4-2** Sample service group that includes an NFSRestart resource

## Agent functions for NFSRestart agent

The agent functions for this agent follow:

### Online

For the lower NFSRestart resource:

- If the value of the NFSLockFailover attribute is 1, the agent terminates statd and lockd.

For the upper NFSRestart resource:

- If the value of the NFSLockFailover attribute is 1, the agent copies the NFS record locks from shared storage to /var/statmon/sm directory.
- Starts the statd and lockd daemons.
- Starts the smsyncd daemon to copy the contents of /var/statmon/sm directory to the shared storage (LocksPathName) at regular two second intervals.

### Monitor

For the lower NFSRestart resource:

- The monitor agent function does nothing.

For the upper NFSRestart resource:

- If the value of the NFSLockFailover attribute is 1, the agent monitors smsyncd daemon. It restarts the smsyncd daemon if it is not running.
- Monitors the statd and lockd daemons.

Offline	<p>For the lower NFSRestart resource:</p> <ul style="list-style-type: none"><li>■ Restarts all the NFS daemons that the upper NFSRestart resource stopped previously.</li></ul> <p>For the upper NFSRestart resource:</p> <ul style="list-style-type: none"><li>■ Terminates the statd and lockd daemons to clear the lock state.</li><li>■ Terminates the nfsd and mountd daemons to close the TCP/IP connections.</li><li>■ Terminates the smsyncd daemon if the daemon is running.</li></ul>
Clean	<p>For the lower NFSRestart resource:</p> <ul style="list-style-type: none"><li>■ Restarts all the NFS daemons that the upper NFSRestart resource stopped previously.</li></ul> <p>For the upper NFSRestart resource:</p> <ul style="list-style-type: none"><li>■ Terminates the statd and lockd daemons to clear the lock state.</li><li>■ Terminates the nfsd and mountd daemons to close the TCP/IP connections.</li><li>■ Terminates the smsyncd daemon if the daemon is running.</li></ul>
Action	<ul style="list-style-type: none"><li>■ nfsconf.vfd Checks the runlevel information of the system service nfslock to confirm that the lock daemons do not come online automatically after reboot.</li><li>■ lockdir.vfd Verifies that the NFS lock directory (which is specified by the LocksPathName attribute of NFSRestart) is on shared storage.</li></ul>

## State definitions

ONLINE	Indicates that the daemons are running properly.
OFFLINE	Indicates that one or more daemons are not running.
UNKNOWN	Indicates the inability to determine the agent's status.

## Attributes for NFSRestart agent

**Table 4-2** Required attributes

Required attribute	Description
NFSRes	Name of the NFS resource. Do not set this to the name of the Proxy resource that points to the NFS resource.  Type and dimension: string-scalar Example: "nfsres1"

**Table 4-3** Optional attributes

Required attribute	Description
LocksPathName	The path name of the directory to store the NFS locks for all the shared file systems. You can use the pathname of one of the shared file systems for this value.  Type and dimension: string-scalar Example: "/share1x"
NFSLockFailover	A flag that specifies whether the user wants NFS locks to be recovered after a failover  Type and dimension: boolean-scalar Default: 0
LockServers	The maximum number of concurrent lockd threads for execution on a server.  Type and dimension: integer-scalar Default: "20" Example: "25"
Lower	Defines the position of NFSRestart resource in the service group. The NFSRestart resource below the Share resource needs a value of 1.  The NFSRestart resource on the top of the resource dependency tree has a Lower attribute value of 0.  Type and dimension: integer-scalar Default: 0

## Resource type definition for NFSRestart agent

```
type NFSRestart (
  static str ArgList[] = { LocksPathName, NFSLockFailover,
  LockServers, NFSRes, "NFSRes:Nservers",
  "NFSRes:LockFileTimeout", "NFSRes:UseSMF", Lower, State }
  static keylist SupportedActions = { "lockdir.vfd", "nfsconf.vfd"
  }
  str NFSRes
  str LocksPathName
  boolean NFSLockFailover = 0
  int LockServers = 20
  int Lower = 0
)
```

## Notes for NFSRestart agent

The NFSRestart agent has the following notes:

- [About high availability fire drill](#)
- [Mounting NFS export with the -vers options can cause lock failure](#)
- [Providing a fully qualified host name](#)
- [Service Management Facility—Solaris 10](#)

### About high availability fire drill

The high availability fire drill detects discrepancies between the VCS configuration and the underlying infrastructure on a node; discrepancies that might prevent a service group from going online on a specific node.

For NFSRestart resources, the high availability drill performs the following, it:

- Checks the NFS configuration file to confirm that the NFS server does not come online automatically after reboot.
- Verifies that the NFS lock directory (which is specified by the LocksPathName attribute of NFSRestart) is on shared storage.

For more information about using the high availability fire drill see the *Veritas Cluster Server Administrator's Guide*.

## Mounting NFS export with the -vers options can cause lock failure

For Solaris clients, the NFS lock recovery may fail to work if the NFS export is mounted with the "-vers=3" option.

## Providing a fully qualified host name

You must provide a fully qualified host name, for example, `nfserver.example.edu`, for the NFS server while mounting the file system on the NFS client. If you do not use a fully qualified host name, or if you use a virtual IP address (10.122.12.25) or partial host name (`nfserver`), NFS lock recovery may fail.

If you want to use the virtual IP address or a partial host name, make the following changes to the service database (`hosts`) and the `nsswitch.conf` files:

```
/etc/hosts
```

To use the virtual IP address and partial host name for the NFS server, you need to add an entry to the `/etc/hosts` file. The virtual IP address and the partial host name should resolve to the fully qualified host name.

```
/etc/nsswitch.conf
```

You should also modify the `hosts` entry in this file so that upon resolving a name locally, the host does not first contact NIS/DNS, but instead immediately returns a successful status. Changing the `nsswitch.conf` file might affect other services running on the system.

For example:

```
hosts: files [SUCCESS=return] dns nis
```

You have to make sure that the NFS client stores the same information for the NFS server as the client uses while mounting the file system. For example, if the NFS client mounts the file system using fully qualified domain names for the NFS server, then the `/var/statmon/sm` directory on the NFS client should also contain a fully qualified domain name of the NFS server after the acquisition of locks. Otherwise you need to stop and start the status daemon and lock daemon to clear the lock cache of the NFS client.

A time period exists where the virtual IP address is online but locking services are not registered on the server. Any NFS client trying to acquire a lock in this interval would fail and get ENOLCK error.

Every two seconds, the `smSyncd` daemon copies the list of clients that hold the locks on the shared filesystem in the service group. If the service group fails before

smsyncd has a chance to copy the client list, the clients may not get a notification once the service group is brought up. This causes NFS lock recovery failure.

## Service Management Facility—Solaris 10

You need to enable the NFS attribute UseSMF to enable monitoring of NFS and Lock daemons through Service Management Facility in Solaris.

If the UseSMF NFS attribute is not enabled, then you must disable the Service Management Facility (SMF) for NFS daemons for the NFSRestart agent to work on Solaris 10. SMF is the service framework for Solaris 10 starting from build 64. SMF provides an infrastructure to automatically start and restart services. Previously, UNIX start-up scripts and configuration files performed these functions.

SMF maintains the Service Configuration Repository, which stores persistent configuration information and runtime data for all the services. Thus, SMF now controls all NFS locking daemons (lockd, statd, etc.) To keep these daemons under VCS control, you need to modify the configuration repository to disable the SMF framework for NFS daemons.

You must invoke the following command before bringing the NFSRestart agent online or the agents returns an UNKNOWN state.

### To keep the statd daemon under VCS control

- 1 Set the auto\_enable property to false.

```
# svccfg -s nfs/status setprop "application/auto_enable = false"
```

- 2 Refresh the SMF configuration repository.

```
# svcadm refresh nfs/status
```

- 3 Disable SMF.

```
# svcadm disable svc:/network/nfs/status:default
```

- 4 Run `svcs -a | grep -i nfs` command and review its output to make sure that SMF for statd is disabled.

```
# svcs -a | grep -i nfs
disabled      May_29      svc:/network/nfs/status:default
```



### To keep lockd daemon under VCS control

- 1 Set the `auto_enable` property to false.

```
# svccfg -s nfs/nlockmgr setprop "application/auto_enable =  
false"
```

- 2 Refresh the SMF configuration repository.

```
# svcadm refresh nfs/nlockmgr
```

- 3 Disable SMF.

```
# svcadm disable svc:/network/nfs/nlockmgr:default
```

- 4 Run `svcs -a | grep -i nfs` command and review its output to make sure that SMF for `nlockmgr` is disabled.

```
# svcs -a | grep -i nlockmgr  
disabled      May_29   svc:/network/nfs/nlockmgr:default
```

### To manually restart lockd, statd, and automountd

- For lockd:

```
# /usr/lib/nfs/lockd
```

- For statd:

```
# /usr/lib/nfs/statd
```

- For automountd:

```
# /usr/lib/fs/autofs/automount
```

```
# /usr/lib/autofs/automountd
```

## Sample configurations for NFSRestart agent

On each node in your cluster, you can find sample NFS, NFSRestart, and Share configurations in `/etc/VRTSvcs/conf/sample_nfs/`.

For more information regarding agent configuration, refer to the *Veritas Cluster Server Administrator's Guide*.

## Basic agent configurations

For NFS lock recovery:

```
NFSRestart nfsrestart (
NFSRes = nfsres
LocksPathName="/shared_mnt/lockinfo"
NFSLockFailover = 1
Lower = 0
)
NFSRestart nfsrestart_L (
NFSRes = nfsres
LocksPathName="/shared_mnt/lockinfo"
NFSLockFailover = 1
Lower = 1
)
```

For no NFS lock recovery:

```
NFSRestart nfsrestart (
NFSRes = nfsres
)
NFSRestart nfsrestart_L (
NFSRes = nfsres
Lower = 1
)
```

## Debug log levels for NFSRestart agent

The NFSRestart agent uses the following debug log levels:

DBG\_1, DBG\_3, DBG\_4, DBG\_5

## Share agent

Shares, unshares, and monitors a single local resource for exporting an NFS file system to be mounted by remote systems.

Before you use this agent, verify that the files and directories to be exported are on shared disks.

For important information on this agent, refer to:

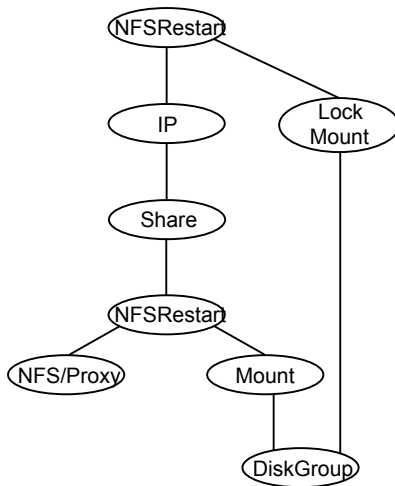
[Notes for Share agent](#)

## Dependencies for Share agent

For more information regarding Share resource dependencies, refer to the *Veritas Cluster Server Administrator's Guide*.

Share resources depend on NFS. In an NFS service group, the IP family of resources depends on Share resources.

**Figure 4-3** Sample service group that include a Share resource



## Agent functions for Share agent

Online	Shares an NFS file system.
Offline	Unshares an NFS file system.
Monitor	Reads /etc/dfs/sharetab file and looks for an entry for the file system specified by PathName. If the entry exists, monitor returns ONLINE. If you specify the share options, the agent verifies whether the directory is shared with the specified options or not. If the directory is not shared with the specified options, a warning is displayed.
Clean	Terminates all ongoing resource actions and takes the resource offline, forcibly when necessary.

Action	<p>direxists.vfd</p> <p>Checks if the path specified by the PathName attribute exists on the cluster node. If the path name is not specified, it checks if a corresponding mount point is available to ensure that the path is on shared storage.</p>
--------	---

## State definitions for Share agent

ONLINE	Indicates that specified directory is exported to the client.
OFFLINE	Indicates that the specified directory is not exported to the client.
UNKNOWN	Indicates that the agent could not determine the state of the resource or that the resource attributes are invalid.
FAULTED	Indicates that specified directory is unshared outside the control of VCS.

## Attributes for Share agent

**Table 4-4** Required attributes

Required attribute	Description
PathName	<p>Pathname of the file system to be shared.</p> <p>Type and dimension: string-scalar</p> <p>Example: "/share1x"</p>
NFSRes	This attribute has been deprecated.

**Table 4-5** Optional attributes

Optional attribute	Description
Options	<p>Options for the <code>share</code> command.</p> <p>Type and dimension: string-scalar</p> <p>Example: "-o rw"</p>

## Resource type definition for Share agent

```
type Share (  
  static keylist SupportedActions = { "direxists.vfd" }  
  static str ArgList[] = { PathName, Options, "NFSRes:State" }  
  str PathName  
  str Options  
  str NFSRes  
)
```

## Notes for Share agent

The following section contains notes on the Share agent.

- [High availability fire drill](#)

### High availability fire drill

The high availability fire drill detects discrepancies between the VCS configuration and the underlying infrastructure on a node. These discrepancies might prevent a service group from going online on a specific node. For Share resources, the high availability fire drill checks if the path exists.

For more information about using the high availability fire drill see the *Veritas Cluster Server Administrator's Guide*.

On Solaris 11, the share options in the `/etc/sharetab` file may not match with the options provided in the share command, so a warning message is displayed in the agent log. To avoid this, it is recommended to use the share options in the `/etc/sharetab` file with Options attribute for the resource.

## Sample configurations for Share agent

On each node in your cluster, you can find sample NFS, NFSRestart, and Share configurations in `/etc/VRTSvcs/conf/sample_nfs/`.

For more information regarding agent configuration, refer to the *Veritas Cluster Server Administrator's Guide*.

## Debug log levels for Share agent

The Share agent uses the following debug log levels:

DBG\_1, DBG\_3, DBG\_5

## About the Samba agents

Samba is a suite of programs that allows a system running a UNIX or UNIX-like operating system to provide services using the Microsoft network protocol. Samba supports the following services:

- Filespace
- Printer
- WINS
- Domain Master

Configure these services in the Samba configuration file (`smb.conf`). Samba uses two processes: `smbd` and `nmbd` to provide these services.

VCS provides Samba failover using three agents: `SambaServer`, `NetBios`, and `SambaShare`.

## The Samba agents

- The `NetBios` agent
- The `SambaServer` agent
- The `SambaShare` agent

## Before using the Samba agents

- Verify that `smbd` and `nmbd` always run as daemons. Verify that they cannot be started using the meta-daemon `inetd`.
- Verify that Samba is configured properly and that the Samba configuration file is identical on all cluster systems. The user can replicate the file or store it on a shared disk accessible from all cluster systems.
- If configuring Samba as a WINS server or Domain Master, verify that the Samba lock directory is on the shared disk. This ensures that the WINS server database and Domain Master are created on the shared disk.
- On Solaris 10, before configuring Samba under VCS, disable the Samba service in the SMF configuration.
  - To disable the Samba service in SMF:

```
# svcadm disable network/samba
```

---

**Note:** This change is persistent across reboot.

---

- To check the status of the Samba service at any instance of time:

```
# svcs network/samba
```

STATE	STIME	FMRI
disabled	16:11:53	svc:/network/samba:default

## Supported versions for Samba agents

VCS Samba suite of agents support Samba version 3.0 and above. Please check your samba version using the following command:

```
# smb -V
```

## Notes for configuring the Samba agents

The following notes describe configuration considerations for the Samba agents.

### Configuring multiple SambaServer resources

For configuring multiple SambaServer resources, configure the SocketAddress attribute with the unique value of the address where the respective samba daemon listens for connections. Configure the SambaServer resource as a parent resource of the IP resource. Configure this IP resource with the SocketAddress attribute value.

### Configuring Samba for non-standard configuration files or non-standard lock directories

Configure the PidFile attribute if you use a non-standard configuration file for Samba or if the lock directory (the directory where Samba pid file resides) for Samba is different than the default location. Use the following command to check the standard locations for the Samba configuration file and the lock directory:

#### To check for the default value of the Samba configuration file

- ◆ Enter the following command:

```
# smb -b | grep CONFIGFILE
```

#### To check for the default location of the Samba pidfile

- ◆ Enter the following command:

```
# smb -b | grep PIDDIR
```

## SambaServer agent

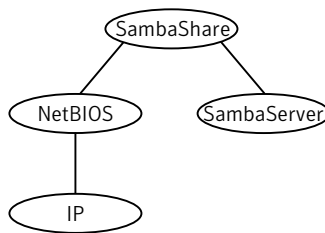
The SambaServer agent starts, stops, and monitors the `smbd` process as a daemon. Only one resource of this type is permitted. You can use the agent to make a `smbd` daemon highly available.

The `smbd` daemon provides Samba share services. The agent verifies that Samba is running by reading the `pid` of `smbd` daemon. The agent can perform in-depth monitoring by establishing a socket connection to Samba at ports where the daemon is listening and sending it a NetBIOS session request.

## Dependencies for SambaServer agent

No dependencies exist for the SambaServer resource.

**Figure 4-4** Sample service group that includes a SambaServer resource



## Agent functions for SambaServer agent

Online	Starts the <code>smbd</code> daemon at specified or default ports.
Offline	Stops the <code>smbd</code> daemon.
Monitor	Verifies that the <code>smbd</code> daemon is running by reading its <code>pid</code> file. Does in-depth monitoring periodically, if configured, by establishing a socket connection to Samba and sending it a NetBIOS session request.
Clean	Stops the <code>smbd</code> daemon forcefully if required.

## State definitions for SambaServer agent

ONLINE	Indicates that the <code>smbd</code> daemon is running. If in-depth monitoring is configured, it indicates that a positive session response packet was received through a socket connection to the Samba server.
--------	--



OFFLINE	Indicates that smbd is not running. If in-depth monitoring is enabled, it indicates that the agent could not establish a socket connection with the server, or that it received an incorrect response packet header, or the session response packet connection timed out.
UNKNOWN	Indicates that the agent could not determine the state of the resource.
FAULTED	Indicates that the smbd daemon has stopped unexpectedly or is not responding (if in-depth monitoring is enabled) outside of VCS control.

## Attributes for SambaServer agent

**Table 4-6** Required attributes

Required attribute	Description
ConfFile	Complete path of the configuration file that Samba uses. Type and dimension: string-scalar Example: "/etc/sfw/smb.conf"
LockDir	Lock directory of Samba. Samba stores the files smbd.pid, nmbd.pid, wins.dat (WINS database), and browse.dat (master browser database) in this directory. Type and dimension: string-scalar Example: "/var/samba/locks"
SambaTopDir	Parent path of Samba daemon and binaries. SambaServer agent uses SambaTopDir attribute value in an open entry point to determine the complete path of samba executables. If this attribute is configured after the resource is enabled, please disable and enable the resource again to bring this into effect as follows: <pre># hares -modify &lt;res&gt; Enabled 0 # hares -modify &lt;res&gt; Enabled 1</pre> Example: "/usr/sfw"

Table 4-7 Optional attributes

Optional attribute	Description
IndepthMonitorCyclePeriod	<p>Number of monitor cycles after which the in-depth monitoring is performed. For example, the value 5 indicates that the agent monitors the resource in-depth every five monitor cycles. The value 0 indicates that the agent will not perform in-depth monitoring for the resource.</p> <p>Type and dimension: integer-scalar</p> <p>Default: 5</p>
Ports	<p>Ports where Samba accepts connections.</p> <p>To run Samba over NBT (NetBios over TCP/IP), set this attribute to 139. To run Samba directly over TCP/IP, set this attribute to 445.</p> <p>Type and dimension: integer-vector</p> <p>Default: 139, 445</p>
ResponseTimeout	<p>Number of seconds the agent waits to receive the session response packet after sending the session request packet. For example, the value 5 indicates that the agent waits for five seconds before receiving the session response packet. Configure this attribute if in-depth monitoring is enabled.</p> <p>Type and dimension: integer-scalar</p> <p>Default: 10</p>
PidFile	<p>The absolute path to the Samba daemon pid file. This file contains the process ID of the monitored smbd process.</p> <p>Configure this attribute if you are using a non-standard configuration file name or path. If this attribute is not configured for non-standard configuration file names, the agent checks the <code>smbd-ConfFile.pid</code> file for monitoring the resource.</p> <p>Type and dimension: string-scalar</p> <p>Example: <code>"/var/samba/locks/smbd.pid"</code></p>
SocketAddress	<p>The IP address where the Samba daemon (smbd) listens for connections. Configure the SocketAddress attribute if you are configuring multiple SambaServer resources on a node.</p> <p><b>Note:</b> Only IPv4 addresses are supported.</p> <p>Type and Dimension: string-scalar</p> <p>Example: <code>"10.128.10.14"</code></p>

## Resource type definitions for SambaServer agent

```
type SambaServer (  
  static str ArgList[] = { ConfFile, SambaTopDir, LockDir, Ports,  
    IndepthMonitorCyclePeriod, ResponseTimeout, PidFile,  
    SocketAddress }  
  str ConfFile  
  str LockDir  
  int Ports[] = { 139, 445 }  
  int IndepthMonitorCyclePeriod = 5  
  int ResponseTimeout = 10  
  str SambaTopDir  
  str PidFile  
  str SocketAddress  
)
```

## Sample configurations for SambaServer agent

The sample configurations for this agent follow:

```
SambaServer samba_server (  
  ConfFile = "/etc/sfw/smb.conf"  
  LockDir = "/var/samba/locks"  
  SambaTopDir = "/usr/sfw"  
  IndepthMonitorCyclePeriod = 3  
  ResponseTimeout = 15  
)
```

## Debug log levels for SambaServer agent

The SambaServer agent uses the following debug log levels:

DBG\_1, DBG\_2, DBG\_3, DBG\_4, DBG\_5

## SambaShare agent

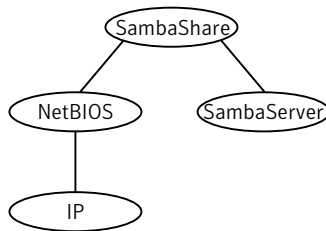
The SambaShare agent adds, removes, and monitors a share by modifying the specified Samba configuration file. You can use the agent to make a Samba Share highly available.

Each filespace service provided by Samba is a shared resource and is defined as a section in the Samba configuration file. The section name is the name of the shared resource and the section parameters define the share attributes.

## Dependencies for SambaShare agent

SambaShare resources depend on the SambaServer, NetBios and Mount resources.

**Figure 4-5** Sample service group for a SambaShare resource



## Agent functions for SambaShare agent

Online	Edits the samba configuration file and adds the shares.
Offline	Removes the shares from the configuration file.
Monitor	Issues the command <code>smbclient</code> to check if the specified shares exist.
Clean	Terminates all ongoing connections with the particular samba share, removes its entry from the samba configuration file and reloads the configuration.

## State definitions for SambaShare agent

ONLINE	Indicates that the share is available.
OFFLINE	Indicates that the share is not available.
FAULTED	Indicates that the share has become unavailable outside of VCS control.
UNKNOWN	Indicates that the agent could not determine the state of the resource.

## Attributes for SambaShare agent

**Table 4-8** Required attributes

Required attribute	Description
SambaServerRes	Name of the SambaServer resource. Type and dimension: string-scalar Example: "smb_res1"
ShareName	Name of the share resource as exported by samba. <b>Note:</b> This name can be different from the SambaShare resource name. Type and dimension: string-scalar Example: "share1"
ShareOptions	List of parameters for the share attributes. These parameters are specified as name=value pairs, with each pair separated by a semicolon (;). Type and dimension: string-scalar Example: "path=/shared; public=yes; writable=yes"

## Resource type definition for SambaShare agent

```

type SambaShare (
  static str ArgList[] = { "SambaServerRes:ConfFile",
    "SambaServerRes:SambaTopDir", "SambaServerRes:LockDir",
    ShareName, ShareOptions, "SambaServerRes:Ports",
    SambaServerRes, "SambaServerRes:PidFile",
    "SambaServerRes:SocketAddress" }
  str SambaServerRes
  str ShareName
  str ShareOptions
)

```

## Sample configuration for SambaShare agent

```

SambaShare Samba_SambaShare3 (
  SambaServerRes = Samba_SambaServer
  ShareName = smbshare3
)

```

```
ShareOptions = "path=/smbshare3; public=yes; writable=yes"  
)
```

## Debug log levels for SambaShare agent

The SambaShare agent uses the following debug log levels:

DBG\_1, DBG\_3, DBG\_5

## NetBios agent

The NetBios agent starts, stops, and monitors the nmbd daemon. Only one resource of this type is permitted. You can use the agent to make the nmbd daemon highly available.

The agent sets, monitors, and resets the names and network interfaces by which the Samba server is known. The agent also sets, monitors and resets Samba to act as a WINS server or domain master or both.

---

**Note:** The nmbd broadcasts the NetBIOS name, or the name by which the Samba server is known in the network.

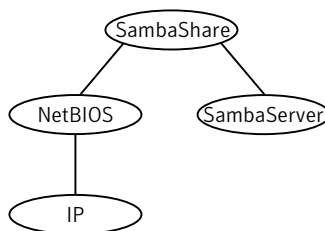
---

## Dependencies for NetBios agent

The NetBios resource depends on the IP, IPMultiNIC, or IPMultiNICB resource if the virtual IP address configured in the IP/IPMultiNIC resource is being used in the Interfaces attribute of the NetBios resource.

The NetBios resource depends on the IP, IPMultiNIC, or IPMultiNICB resource if the virtual IP address configured in the IP/IPMultiNIC or IPMultiNICB resource is being used in the Interfaces attribute of the NetBios resource.

**Figure 4-6** Sample service group that includes a NetBIOS resource



## Agent functions for NetBios agent

Online	Updates the Samba configuration with the NetBIOS name, all NetBIOS aliases and network interfaces, WINS support, and domain master options specified in the NetBIOS resource. Starts the nmbd daemon.
Offline	Removes the NetBIOS name, all NetBIOS aliases and network interfaces, WINS support, and domain master options specified in the NetBIOS resource from the Samba configuration file. Stops the nmbd daemon.
Monitor	Verifies that the Samba configuration contains the NetBIOS name, all NetBIOS aliases and network interfaces, WINS support, and domain master options specified in the NetBIOS resource. Also verifies that the nmbd daemon is running by reading its pid file.
Clean	Removes the NetBIOS name, all NetBIOS aliases and network interfaces, WINS support, and domain master options specified in the NetBIOS resource from the Samba configuration file. Stops the nmbd daemon, forcibly when necessary.

## State definitions for NetBios agent

ONLINE	Indicates that the specified NetBIOS name and aliases are advertised and that Samba is handling requests for all specified network interfaces. Indicates that WINS and Domain support services are running, if configured.
OFFLINE	Indicates one or more of the following: <ul style="list-style-type: none"><li>■ NetBIOS name is not advertised.</li><li>■ A NetBIOS alias is not advertised.</li><li>■ Samba is not handling requests on any of the specified interfaces.</li><li>■ If WINS support is configured, Samba is not providing WINS service.</li><li>■ If domain support is set, Samba is not providing Domain Master service.</li></ul>
UNKNOWN	Indicates that the agent could not determine the state of the resource.
FAULTED	Indicates that the resource has become offline unexpectedly outside of VCS control.

## Attributes for NetBios agent

**Table 4-9** Required attributes

Required attribute	Description
NetBiosName	Name by which the Samba server is known in the network. Type and dimension: string-scalar Example: "samba_demon" <b>Note:</b> Samba has a limitation of 15 characters for NetBios names and aliases.
SambaServerRes	Name of the SambaServer resource. Type and dimension: string-scalar Example: "smb_res1"

**Table 4-10** Optional attributes

Optional attribute	Description
Interfaces	List of network interfaces on which Samba handles browsing. Type and dimension: string-vector Example: "172.29.9.24/16" <b>Note:</b> If you have configured the SocketAddress attribute value for the corresponding SambaServer resource, then you must also configure the same value paired with the appropriate netmask in the list of interfaces.
NetBiosAliases	List of additional names by which the Samba server is known in the network. Type and dimension: string-vector Example: { host1_samba, myname } <b>Note:</b> Samba has a limitation of 15 characters for NetBios names and aliases.
WinsSupport	If set to 1, this flag causes the agent to configure Samba as a WINS server. Type and dimension: integer-scalar Default: 0



**Table 4-10** Optional attributes (*continued*)

Optional attribute	Description
DomainMaster	<p>If set to 1, the agent sets Samba as Domain Master. Note that there can be only one domain master in a domain.</p> <p>Type and dimension: integer-scalar</p> <p>Default: 0</p>
PidFile	<p>The absolute path to the NetBIOS daemon pid file. This file contains the process ID of the monitored nmbd process.</p> <p>Configure this attribute if you are using a nonstandard configuration file name or path. If this attribute is not configured for non-standard configuration file names, the agent checks for the nmbd-<i>ConfFile</i>.pid file for resource monitoring.</p> <p>Type and dimension: string-scalar</p> <p>Example: "/var/samba/locks/nmbd.pid"</p>

## Resource type definition for NetBios agent

```

type NetBios (
  static str ArgList[] = { "SambaServerRes:ConfFile",
    "SambaServerRes:SambaTopDir", "SambaServerRes:LockDir",
    NetBiosName, NetBiosAliases, Interfaces, WinsSupport,
    DomainMaster, "SambaServerRes:PidFile", SambaServerRes,
    PidFile }
  str SambaServerRes
  str NetBiosName
  str NetBiosAliases[]
  str Interfaces[]
  int WinsSupport
  int DomainMaster
  str PidFile
)

```

## Sample configuration for NetBios agent

```

NetBios Samba_NetBios (
  SambaServerRes = Samba_SambaServer
  NetBiosName = samba_demon
  NetBiosAliases = { asamba_demon, samba127 }
)

```

```
WinsSupport = 1  
DomainMaster = 1  
)
```

## Debug log levels for NetBios agent

The NetBios agent uses the following debug log levels:

DBG\_1, DBG\_5

# Service and application agents

This chapter includes the following topics:

- [About the services and applications agents](#)
- [Apache HTTP server agent](#)
- [Application agent](#)
- [CoordPoint agent](#)
- [Process agent](#)
- [ProcessOnOnly agent](#)
- [Zone agent](#)
- [LDom agent](#)
- [Project agent](#)
- [AlternatelO agent](#)

## About the services and applications agents

Use service and application agents to provide high availability for application and process-related resources.

## Apache HTTP server agent

The Apache HTTP server agent brings an Apache Server online, takes it offline, and monitors its processes. The Apache HTTP server agent consists of resource

type declarations and agent scripts. You use the Apache HTTP server agent, in conjunction with other agents, to make an Apache HTTP server highly available.

This agent supports the Apache HTTP server 2.0 and 2.2. It also supports the IBM HTTP Server 1.3, 2.0 and 7.0.0.0.

This agent can detect when an Apache HTTP server is brought down gracefully by an administrator. When Apache is brought down gracefully, the agent does not trigger a resource fault even though Apache is down.

---

**Note:** The Apache agent requires an IP resource for operation.

---

On Solaris 11, the Apache HTTP server agent requires the `pkg:/compatibility/ucb` package to be available on the system.

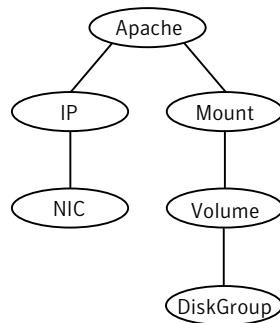
For more information regarding this agent:

See [“Apache HTTP server notes”](#) on page 187.

## Dependencies

This type of resource depends on IP and Mount resources.

**Figure 5-1** Sample service group for the Apache HTTP server agent



## Agent functions

Online	<p>To start the Apache HTTP server, the agent:</p> <ul style="list-style-type: none"><li>■ Executes the httpdDir/httpd program with the appropriate arguments if the httpdDir program specifies the full path of the directory in which the httpd binary file is located.</li><li>■ Alternatively, if the httpdDir attribute specifies the full path of the Apache HTTP server binary file, the binary file is executed with appropriate arguments.</li></ul> <p>When you specify a file with the EnvFile attribute, the file is sourced before the agent executes the Apache HTTP server commands.</p>
Offline	<p>To stop the Apache HTTP server, the agent:</p> <ul style="list-style-type: none"><li>■ Executes the httpdDir/httpd program with the appropriate arguments, if httpdDir specifies the full path of the directory in which the httpd binary file is located.</li><li>■ Alternatively, if the httpdDir attribute is used to specify the full path of the Apache HTTP server binary, the binary file is executed with appropriate arguments.</li><li>■ Sends a TERM signal to the HTTP Server parent process (Apache).</li></ul> <p>When you specify a file with the EnvFile attribute, the file is sourced before the agent executes the Apache HTTP server commands.</p>
Monitor	<p>Monitors the state of the Apache server. First it checks for the processes, next it can perform an optional state check.</p>
Clean	<p>Removes the Apache HTTP server system resources that might remain after a server fault or after an unsuccessful attempt to online or offline. These resources include the parent httpd daemon and its child daemons.</p>
Action	<p>checkconffile.vfd</p> <p>Checks for the existence of the Apache configuration file and the existence of the directory that contains the httpd binary that is used during start up.</p> <p>For a local installation, if the config file or HttpdDir is not found, make sure that it exists on the failover node.</p>

## State definitions

ONLINE	Indicates that the Apache server is running.
--------	--

OFFLINE	Indicates that the Apache server is not running.  Can also indicate that the administrator has stopped the HTTP server gracefully. Note that the agent uses the PidFile attribute for intentional offline detection.
UNKNOWN	Indicates that a problem exists with the configuration.

## Attributes

**Table 5-1** Required attributes

Required attribute	Description
ConfigFile	Full path and file name of the main configuration file for the Apache server.  Type and dimension: string-scalar Example: "/apache/server1/conf/httpd.conf"
httpdDir	Full path of the Apache HTTP server binary file or full path of the directory in which the httpd binary file is located.  Type and dimension: string-scalar Example: "/apache/server1/bin"
PidFile	This attribute is required when you want to enable the detection of a graceful shutdown outside of VCS control.  See <a href="#">Table 5-2</a> on page 182.
EnvFile	This attribute may be required when you use IBM HTTP Server.  See <a href="#">Table 5-2</a> on page 182.

**Table 5-2** Optional attributes

Optional attribute	Description
DirectiveAfter	A list of directives that httpd processes after reading the configuration file.  Type and dimension: string-association Example: DirectiveAfter{} = { KeepAlive=On }

**Table 5-2** Optional attributes (*continued*)

Optional attribute	Description
DirectiveBefore	<p>A list of directives that httpd processes before it reads the configuration file.</p> <p>Type and dimension: string-association</p> <p>Example: DirectiveBefore{} = { User=nobody, Group=nobody }</p>
User	<p>Account name the agent uses to execute the httpd program. If you do not specify this value, the agent executes httpd as the root user.</p> <p>Type and dimension: string-scalar</p> <p>Example: "apache1"</p>
EnableSSL	<p>If this attribute is set to 1 (true) the online agent function will add support for SSL, by including the option <code>-DSSL</code> in the start command.</p> <p>For example: <code>/usr/sbin/httpd -f path_to_httpd.conf -k start -DSSL</code></p> <p>Where <code>path_to_httpd.conf</code> file is the path to the <code>httpd.conf</code> file.</p> <p>If this attribute is set to 0 (false) the agent excludes the SSL support.</p> <p>Type and dimension: boolean-scalar</p> <p>Default: 0</p> <p>Example: "1"</p>
HostName	<p>The virtual host name that is assigned to the Apache server instance. The host name is used in second-level monitoring for benchmarking the Apache HTTP server.</p> <p>You can use IPv4 or IPv6 addresses for the HostName attribute.</p> <p><b>Note:</b> The HostName attribute is only required when the value of <code>SecondLevelMonitor</code> is 1 (true).</p> <p>Type and dimension: string-scalar</p> <p>Example: "web1.example.com"</p>

**Table 5-2** Optional attributes (*continued*)

Optional attribute	Description
Port	<p>Port number where the Apache HTTP server instance listens. The port number is used in second-level monitoring for benchmarking the Apache HTTP server. Specify this attribute only if SecondLevelMonitor is set to 1 (true).</p> <p>Type and dimension: integer-scalar</p> <p>Default: 80</p> <p>Example: "80"</p>
EnvFile	<p>Full path and file name of the file that is sourced before executing Apache HTTP server commands. With Apache 2.0, the file <i>ServerRoot/bin/envvars</i>, which is supplied in most Apache 2.0 distributions, is commonly used to set the environment before executing httpd. Specifying this attribute is optional. If EnvFile is specified, the shell for user must be Bourne, Korn, or C shell.</p> <p>This attribute may be required when you use the IBM HTTP Server if the online action fails. For example: set the EnvFile to <i>/usr/IBM/HTTPServer/bin/envvars</i>.</p> <p>Type and dimension: string-scalar</p> <p>Example: "/apache/server1/bin/envvars"</p>
PidFile	<p>The PidFile attribute sets the file to which the server records the process ID of the daemon. The value of PidFile attribute must be the absolute path where the Apache instance records the pid.</p> <p>This attribute is required when you want the agent to detect the graceful shutdown of the Apache HTTP server. For the agent to detect the graceful shutdown of the Apache HTTP server, the value of the IntentionalOffline resource type attribute must be 1 (true).</p> <p>Type and dimension: string-scalar</p> <p>Example: <i>/var/run/httpd.pid</i></p>



**Table 5-2** Optional attributes (*continued*)

Optional attribute	Description
SharedObjDir	<p>Full path of the directory in which the Apache HTTP shared object files are located. Specifying this attribute is optional. It is used when the HTTP Server is compiled using the SHARED_CORE rule. If you specify this attribute, the directory is passed to the <code>-R</code> option when executing the <code>httpd</code> program. Refer to the <code>httpd</code> man pages for more information about the <code>-R</code> option.</p> <p>Type and dimension: boolean-scalar</p> <p>Example: <code>"/apache/server1/libexec"</code></p>
SecondLevelMonitor	<p>Enables second-level monitoring for the resource. Second-level monitoring is a deeper, more thorough state check of the Apache HTTP server. Valid attribute values are 1 (true) and 0 (false).</p> <p>Type and dimension: boolean-scalar</p> <p>Default: 0</p> <p>Example: <code>"1"</code></p>
SecondLevelTimeout	<p>The number of seconds that the monitor agent function waits on the execution of second-level monitor. If the second-level monitor program does not return to calling the monitor agent function before the <code>SecondLevelTimeout</code> window expires, the monitor agent function no longer blocks on the program sub-process. It does, however, report that the resource is offline. The value should be high enough to allow the second level monitor enough time to complete. The value should be less than the value of the agent's <code>MonitorTimeout</code>.</p> <p>Type and dimension: integer-scalar</p> <p>Default: 30 Table</p>

**Table 5-2** Optional attributes (*continued*)

Optional attribute	Description
ResLogLevel	<p>Controls the agent's logging detail for a specific instance of a resource. Values are</p> <ul style="list-style-type: none"> <li>■ ERROR: Logs error messages.</li> <li>■ WARN: Logs error and warning messages</li> <li>■ INFO: Logs error, warning, and informational messages.</li> <li>■ TRACE: Logs error, warning, informational, and trace messages. Trace logging is verbose. Use for initial configuration or troubleshooting.</li> </ul> <p>Type and dimension: string-scalar</p> <p>Default: INFO</p> <p>Example: "TRACE"</p>

**Table 5-3** Resource type attribute

Optional attribute	Description
IntentionalOffline	For information on how to use the IntentionalOffline resource type attribute, refer to the <i>Veritas Cluster Server Administrator's Guide</i> .

## Resource type definition

```

type Apache (
    static keylist SupportedActions = { "checkconf.vfd" }
    static str ArgList[] = { ResLogLevel, State, IState, httpdDir,
        SharedObjDir, EnvFile, PidFile, HostName, Port, User,
        SecondLevelMonitor, SecondLevelTimeout, ConfigFile, EnableSSL,
        DirectiveAfter, DirectiveBefore }
    str ResLogLevel = INFO
    str httpdDir
    str SharedObjDir
    str EnvFile
    str PidFile
    str HostName
    int Port = 80
    str User
    int SecondLevelTimeout = 30
    str ConfigFile = 0

```

```
    str DirectiveAfter{}
    str DirectiveBefore{}
    boolean EnableSSL

    static int ContainerOpts{} = { RunInContainer=1, PassCInfo=0 }

    static boolean IntentionalOffline = 0
)

```

## Apache HTTP server notes

The Apache Apache HTTP server has the following notes:

- See [“Tasks to perform before you use the Apache HTTP server agent”](#) on page 187.
- See [“About detecting application failure”](#) on page 188.
- See [“About bringing an Apache HTTP server online outside of VCS control”](#) on page 188.
- See [“About high Availability fire drill”](#) on page 189.

## Tasks to perform before you use the Apache HTTP server agent

Before you use this agent, perform the following tasks:

- Install the Apache server on shared or local disks.
- Ensure that you are able to start the Apache HTTP server outside of VCS control, with the specified parameters in the Apache configuration file (for example: `/etc/apache/httpd.conf`). For more information on how to start the server: See [“About bringing an Apache HTTP server online outside of VCS control”](#) on page 188.
- Specify the location of the error log file in the Apache configuration file for your convenience (for example: `ErrorLog /var/apache/logs/error_log`).
- Verify that the floating IP has the same subnet as the cluster systems.
- If you use a port other than the default 80, assign an exclusive port for the Apache server.
- Verify that the Apache server configuration files are identical on all cluster systems.
- Verify that the Apache server does not autostart on system startup.
- Verify that `inetd` does not invoke the Apache server.

- The service group has disk and network resources to support the Apache server resource.
- Assign virtual host name and port to Apache Server.

## About detecting application failure

The agent provides two methods to evaluate the state of an Apache HTTP server instance. The first state check is mandatory and the second is optional.

The first check determines the state of the Apache HTTP server. The check determines the state by searching for the existence of the parent httpd daemon. It also searches for at least one child httpd daemon. If the parent process and at least one child do not exist, VCS reports the resource as offline. If they do exist, and if the agent attribute `SecondLevelMonitor` is set to true, then the Apache agent uses the Apache Benchmarking utility "ab" to perform detail monitoring. If the exit code of the "ab" utility is 0 and if the command output contains "Benchmarking HostName", the agent considers the server online, else the agent considers the server offline.

If the binary file `ab` is not found, Apache agent uses the `ab2` binary file for detail monitoring.

## About bringing an Apache HTTP server online outside of VCS control

When you bring an Apache HTTP server online outside of VCS control, first source its environment file. Start the server with the `-f` option so the server knows which instance to start. You can then specify additional options (such as `EnableSSL` or `SharedObjDir`) that you want the server to use at start.

### To start an Apache HTTP server outside of VCS control

- 1 Source the environment file if required.
- 2 Start the Apache HTTP server. You must use the `-f` option so that the agent can distinguish different instances of the server.

```
httpdDir/httpd -f ConfigFile -k start
```

Where `httpdDir` is `/apache/v2.2/bin` `ConfigFile` is `/apache/v2.2/conf/httpd.conf`.  
When fully formed, the start example looks like:

```
/apache/v2.2/bin/httpd -f /apache/v2.2/conf/httpd.conf -k start
```

- 3 Specify additional options such as `EnableSSL` or `SharedObjDir` that you want to use when you start server. When you add `EnableSSL` to the command, it resembles:

```
httpdDir/httpd -f ConfigFile -k start -DSSL
```

---

**Note:** You can specify the full path of a binary file without having `httpd` as part of `httpdDir` attribute.

For example:

---

```
/usr/sbin/apache2 -f /etc/httpd/conf/httpd.conf -k start
```

## About high Availability fire drill

The high availability fire drill detects discrepancies between the VCS configuration and the underlying infrastructure on a node. These discrepancies might prevent a service group from going online on a specific node.

For Apache resources, when the Apache HTTP server is installed locally, the high availability fire drill checks for the validity of these attributes:

- `ConfigFile`
- `httpdDir`

For more information about using the high availability fire drill see the *Veritas Cluster Server Administrator's Guide*.

## Sample configurations

### Basic configuration for Solaris

The following is a basic configuration for the resource.

```
group ApacheG1 (
  SystemList = { host1 = 0, host2 = 1 }
)
Apache httpd_server (
  httpdDir = "/apache/bin"
  HostName = vcssl1
  Port = 8888
  User = root
  SecondLevelMonitor = 1
  ConfigFile = "/apache/conf/httpd.conf"
)
DiskGroup Apache_dg (
  DiskGroup = apc1
)
IP Apache_ip (
  Device = bge0
  Address = "11.123.99.168"
  NetMask = "255.255.254.0"
)
Mount Apache_mnt (
  MountPoint = "/apache"
  BlockDevice = "/dev/vx/dsk/apc1/apcvoll"
  FSType = vxfs
  FsckOpt = "-y"
)
Apache_mnt requires Apache_dg
httpd_server requires Apache_mnt
httpd_server requires Apache_ip
```

### Basic IPv6 configuration

The following is a basic IPv6 configuration for the resource.

```
group ipv6group (
  SystemList = { sysA = 0, sysB = 1 }
)

Apache ipv6group_apache_res (
```

```
    HostName = "fd4b:454e:205a:110:211:25ff:fe7e:118"
    PidFile = "/myapache/apache/logs/httpd.pid"
    httpdDir = "/myapache/apache/bin"
    ConfigFile = "/myapache/apache/conf/httpd.conf"
    ResLogLevel = TRACE
    SecondLevelTimeout = 20
    IntentionalOffline = 1
)

DiskGroup ipv6group_dg_res (
    DiskGroup = dg01
)

IP ipv6group_ip_res (

    Device = bge0

    Address = "fd4b:454e:205a:110:211:25ff:fe7e:118"
    PrefixLen = 64
)

Mount ipv6group_mnt_res (
    MountOpt = rw
    FsckOpt = "-n"
    BlockDevice = "/dev/vx/dsk/dg01/vol01"
    MountPoint = "/myapache/apache"
    FSType = vxfs
)

NIC ipv6group_nic_res (

Device = bge0

)

Volume ipv6group_vol_res (
    Volume = vol01
    DiskGroup = dg01
)

ipv6group_apache_res requires ipv6group_mnt_res
ipv6group_apache_res requires ipv6group_ip_res
ipv6group_mnt_res requires ipv6group_vol_res
```

```
ipv6group_vol_res requires ipv6group_dg_res  
ipv6group_ip_res requires ipv6group_nic_res
```

## Application agent

The Application agent brings applications online, takes them offline, and monitors their status. Use it to specify different executables for the online, offline, and monitor routines for different programs. The executables can be on local storage or shared storage. You can use this agent to provide high availability for applications that do not have bundled, enterprise, or custom agents.

An application runs in the default context of root. Specify the user name to run an application in a user context.

You can monitor the application in the following ways:

- Use the monitor program
- Specify a list of processes
- Specify a list of process ID files
- Any combination of the above

This agent is zone-aware. The ContainerOpts resource type attribute for this type has a default value of 1 for RunInContainer and a default value of 0 for PassCInfo. Symantec recommends that you do not change these values.

Refer to the *Storage Foundation High Availability Virtualization Guide* for more information.

This agent is IMF-aware and uses asynchronous monitoring framework (AMF) kernel driver for IMF notification. For more information about the Intelligent Monitoring Framework (IMF) and intelligent resource monitoring, refer to the *Veritas Cluster Server Administrator's Guide*.

Prevention Of Concurrency Violation (ProPCV) can be enabled to prevent an online resource on a node from coming online on another node, outside of VCS control, in the same cluster. In that, ProPCV prevents the execution of StartProgram and processes that are configured in MonitorProcesses on the offline node. This action prevents data corruption of resources and detects concurrency violation at an early stage. The attribute can only be set for a local failover type group. To enable this feature you need to set the ProPCV attribute value to 1. For more information about ProPCV, refer to the *Veritas Cluster Server Administrator's Guide*.



## High availability fire drill for Application agent

The high availability fire drill detects discrepancies between the VCS configuration and the underlying infrastructure on a node. These discrepancies might prevent a service group from going online on a specific node. For Application resources, the high availability fire drill checks for:

- The availability of the specified program and execution permissions for the specified program (program.vfd)
- The existence of the specified user on the host (user.vfd)
- The existence of the same binary on all nodes (cksum.vfd)

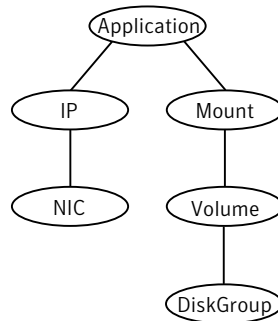
For more information, refer to the *Veritas Cluster Server Administrator's Guide*.

## Dependencies for Application agent

No fixed dependency exists for Application agent.

Depending on how you plan to use it, an Application type of resource can depend on IP and Mount resources. Alternatively, instead of the IP resource you can also use the IPMultiNIC or IPMultiNICB resource.

**Figure 5-2** Sample service group that includes an Application resource



## Agent functions for Application agent

Online

Runs the command or script that you specify in the value of the StartProgram attribute. Runs the command with the specified parameters in the context of the specified user.

To bring the resource online, the agent function performs the command:

```
su [-] user -c command_to_online_resource
```

Offline	<p>Runs the command or script that you specify in the value of the StopProgram attribute. Runs the command with the specified parameters in the context of the specified user.</p> <p>To take the resource offline, the agent function performs the command:</p> <pre>su [-] user -c <i>command_to_offline_resource</i></pre>
Monitor	<p>If you specify the MonitorProgram attribute, the agent executes the user defined MonitorProgram in the user-specified context. If you specify the PidFiles attribute, the routine verifies that the process ID that is found in each listed file is running. If you specify the MonitorProcesses attribute, the routine verifies that each listed process is running in the context of the user you specify.</p> <p>Use any combination among these attributes (MonitorProgram, PidFiles, or MonitorProcesses) to monitor the application.</p> <p>If any of the processes that are specified in either PidFiles or MonitorProcesses is determined not to be running, the monitor returns OFFLINE. If the process terminates ungracefully, the monitor returns OFFLINE and failover occurs.</p> <p>To monitor the resource, the agent function performs the command:</p> <pre>su [-] user -c <i>command_to_monitor_resource</i></pre>
imf_init	<p>Initializes the agent to interface with the asynchronous monitoring framework (AMF) kernel driver. This function runs when the agent starts up.</p>
imf_getnotification	<p>Gets notification about resource state changes. This function runs after the agent initializes with the AMF kernel driver. The agent continuously waits for notification and takes action on the resource upon notification.</p>
imf_register	<p>Registers the resource entities, which the agent must monitor, with the AMF kernel driver. For example, the function registers the PID for online monitoring of a process. This function runs for each resource after the resource goes into steady state (online or offline). The Application agent uses IMF for the processes configured with PidFiles and the MonitorProcesses attribute.</p>

Clean	<p>Terminates processes specified in PidFiles or MonitorProcesses. Ensures that only those processes (that are specified in the MonitorProcesses attribute) running with the user ID specified in the User attribute are killed. If the CleanProgram is defined, the agent executes the CleanProgram.</p> <p>To forcefully stop the resource, the agent function performs the command:</p> <pre>su [-] user -c <i>command_to_clean_resource</i></pre> <p>Note that the agent uses the <code>su -</code> option only when the attribute UseSUDash is enabled (1). The UseSUDash attribute is disabled (0) by default.</p>
Action	<p>The various functions of the action entry point are as follows:</p> <ul style="list-style-type: none"><li>■ <code>program.vfd</code> Checks the availability of the specified program and the execution permissions for the specified program.</li><li>■ <code>user.vfd</code> Checks the existence of the specified user on the host.</li><li>■ <code>cksum.vfd</code> Checks the existence of the same binary on all nodes.</li><li>■ <code>propcv</code> [For internal use only] Invokes the AMF call with arguments to decide whether to allow or prevent processes from starting for an application resource, outside the VCS control, in the cluster. The StartProgram and the processes configured under MonitorProcesses, registered with AMF for offline monitoring, are prevented from starting on the offline node. This helps prevent concurrency violation at an early stage.</li><li>■ <code>getcksum</code> Returns the checksum of the specified program</li></ul>

## State definitions for Application agent

ONLINE	Indicates that all processes that are specified in the PidFiles and the MonitorProcesses attribute are running and that the MonitorProgram returns ONLINE.
OFFLINE	Indicates that at least one process that is specified in the PidFiles attribute or MonitorProcesses is not running, or that the MonitorProgram returns OFFLINE.

UNKNOWN	Indicates an indeterminable application state or invalid configuration or that the required attributes have not been configured.
FAULTED	Indicates that the process has terminated unexpectedly or MonitorProgram returns "offline" unexpectedly.

## Attributes for Application agent

**Table 5-4** Required attributes for Solaris

Required attribute	Description
StartProgram	<p>The executable, which starts the application. Specify the complete path of the executable. Applicable command line arguments follow the name of the executable and have spaces separating them. This executable can be on local storage or shared storage.</p> <p>For example, if the attribute for StartProgram is</p> <pre>/usr/sbin/vxnotify -g dg00 -m &gt;&gt; /var/log/vxnotify.log</pre> <p>(and vxnotify is blocking command) set it like:</p> <pre>/usr/sbin/vxnotify -g dg00 -m &gt;&gt; /var/log/vxnotify.log &amp;</pre> <p>For applications running in Solaris zones, use the path as seen from the non-global zone.</p> <p><b>Note:</b> Do not use the opening and closing ({} ) brace symbols in this string.</p> <p>Type and dimension: string-scalar</p> <p>Example: "/usr/sbin/sample_app start"</p>
StopProgram	<p>The executable, which stops the application. Specify the complete path of the executable. Applicable command line arguments follow the name of the executable and have spaces separating them. This executable can be on local storage or shared storage.</p> <p>For applications running in Solaris zones, use the path as seen from the non-global zone.</p> <p><b>Note:</b> Do not use the opening and closing ({} ) brace symbols in this string.</p> <p>Type and dimension: string-scalar</p> <p>Example: "/usr/sbin/sample_app stop"</p>

**Table 5-4** Required attributes for Solaris (*continued*)

Required attribute	Description
At least one of the following attributes: <ul style="list-style-type: none"> <li>■ MonitorProcesses</li> <li>■ MonitorProgram</li> <li>■ PidFiles</li> </ul>	See <a href="#">Table 5-5</a> on page 197.

**Table 5-5** Optional attributes for Solaris

Optional attribute	Description
CleanProgram	<p>The executable, which forcibly stops the application. Specify the complete path of the executable. Applicable command line arguments follow the name of the executable and have spaces separating them. This executable can be on local storage or shared storage.</p> <p><b>Note:</b> Symantec recommends to have the CleanProgram on the local storage so that in case of loss of storage connectivity VCS can take appropriate action to stop the application.</p> <p>For applications running in Solaris zones, use the path as seen from the non-global zone.</p> <p>Type and dimension: string-scalar</p> <p>Example: "/usr/sbin/sample_app force stop"</p>
MonitorProcesses	<p>A list of processes that you want to be monitored and cleaned. Each process name is the name of an executable.</p> <p>Provide the full path name of the executable if the agent uses that path to start the executable.</p> <p>The process name must be the full command line argument that the <code>/usr/ucb/ps -ww &lt;pid&gt;</code> command displays for the process.</p> <p>Type and dimension: string-vector</p> <p>Example: "/app/sample_bin" or "/usr/bin/bash /app/sample_process.sh"</p>

**Table 5-5** Optional attributes for Solaris (*continued*)

Optional attribute	Description
MonitorProgram	<p>The executable, which monitors the application. Specify the complete path of the executable. Applicable command line arguments follow the name of the executable and have spaces separating them. This executable can be on local storage or shared storage.</p> <p>For applications running in Solaris zones, use the path as seen from the non-global zone.</p> <p>MonitorProgram can return the following VCSAgResState values: OFFLINE value is 100 or 1; ONLINE values range from 101 to 110 or 0 (depending on the confidence level); 110 equals confidence level of 100%. Any other value = UNKNOWN.</p> <p><b>Note:</b> Do not use the opening and closing ({} ) brace symbols in this string.</p> <p>If MonitorProgram is configured and not available, then resource state will be:</p> <ul style="list-style-type: none"> <li>■ OFFLINE if the resource was in OFFLINE state and not waiting for any action</li> <li>■ UNKNOWN if the resource was in any other state or waiting for some action.</li> </ul> <p>Type and dimension: string-scalar</p> <p>Example: "/usr/sbin/sample_app_monitor all"</p>
PidFiles	<p>A list of PID (process ID) files that contain the PID of the processes that you want monitored and cleaned. These are application generated files. Each PID file contains one monitored PID. Specify the complete path of each PID file in the list.</p> <p>For applications running in Solaris zones, use the path as seen from the non-global zone.</p> <p>The process ID can change when the process restarts. If the application takes time to update the PID file, the agent's monitor function may return an incorrect result. If incorrect results occur, increase the ToleranceLimit in the resource definition.</p> <p>Type and dimension: string-vector</p> <p>Example:</p> <p>"/var/lock/samba/smbd.pid"</p>

**Table 5-5** Optional attributes for Solaris (*continued*)

Optional attribute	Description
User	<p>The user name for running StartProgram, StopProgram, MonitorProgram, and CleanProgram. The processes that are specified in the MonitorProcesses list must run in the context of the specified user. Monitor checks the processes to make sure they run in this context.</p> <p><b>Note:</b> If configured user does not exist then the resource state will be UNKNOWN.</p> <p>Type and dimension: string-scalar</p> <p>Default: root</p> <p>Example: user1</p>
EnvFile	<p>The environment file that should get sourced before running any of the StartProgram, StopProgram, MonitorProgram or CleanProgram.</p> <p><b>Note:</b> Please make sure that the EnvFile adheres the default shell syntax of the configured use.</p> <p>Type and dimension: string-scalar</p> <p>Default: ""</p> <p>Example: /home/username/envfile</p>
UseSUDash	<p>When the value of this attribute is 0, the agent performs an <code>su user</code> command before it executes the StartProgram, the StopProgram, the MonitorProgram, or the CleanProgram agent functions. When the value of this attribute is 1, the agent performs an <code>su - user</code> command before it executes the StartProgram, the StopProgram, the MonitorProgram or the CleanProgram agent functions.</p> <p>Type and dimension: boolean-scalar</p> <p>Default: 0</p> <p>Example: 1</p>

## Resource type definition for Application agent

```

type Application (
    static keylist SupportedActions = { "program.vfd",
        "user.vfd", "cksum.vfd", getcksum, propcv }
    static keylist RegList = { MonitorProcesses, User }

```

```

static int IMF{} = { Mode = 3, MonitorFreq = 1,
    RegisterRetryLimit = 3 }
static str IMFRegList[] = { MonitorProcesses, User,
    PidFiles, MonitorProgram }
static str ArgList[] = { State, IState, User, StartProgram,
    StopProgram, CleanProgram, MonitorProgram, PidFiles,
    MonitorProcesses, EnvFile, UseSUDash }
static int ContainerOpts{} = { RunInContainer=1, PassCInfo=0 }
str User = root
str StartProgram
str StopProgram
str CleanProgram
str MonitorProgram
str PidFiles[]
str MonitorProcesses[]
str EnvFile
boolean UseSUDash = 0
)

```

## Notes for Application agent

### Using Application agent with IMF

Intelligent monitoring is supported for the Application agent only under specific configurations. The complete list of such configurations is provided in the following table:

**Table 5-6**

MonitorProgram	MonitorProcesses	PidFiles	IMF Monitoring Mode
Not Configured	Not Configured	Not Configured	Not Applicable
Not Configured	Not Configured	Configured	Online, Offline
Not Configured	Configured	Not Configured	Online, Offline
Not Configured	Configured	Configured	Online, Offline
Configured	Not Configured	Not Configured	Offline Only
Configured	Not Configured	Configured	Offline Only



Table 5-6 (continued)

MonitorProgram	MonitorProcesses	PidFiles	IMF Monitoring Mode
Configured	Configured	Not Configured	Offline Only
Configured	Configured	Configured	Offline Only

---

**Note:** When you do not configure MonitorProcesses, IMF monitors only the StartProgram on the offline node. Hence, the MonitorFreq of IMF attribute must be set to 1 so that IMF monitors the resource on the offline node every monitor cycle.

---

**Note:** For a resource, if a PID file configured in the PidFiles attribute and a process configured in the MonitorProcesses attribute have the same process ID (PID), then the resource fails to register to IMF.

---

When multiple processes are configured under the MonitorProcesses attribute and only some of them are running, offline registration with IMF fails repeatedly until RegisterRetryLimit is reached. In such a scenario, IMF cannot determine when the resource goes ONLINE and the agent monitors the resource in the traditional way.

## Using Application agent with ProPCV

ProPCV functionality prevents the StartProgram and binary-based processes that are configured under MonitorProcesses from executing on the offline node. This action detects concurrency violation at an early stage in the cycle. However, ProPCV does not prevent script-based processes that are configured under MonitorProcesses from executing on the offline node. Considerations for ProPCV to function:

- You must run the StartProgram with the same order of arguments as configured in the StartProgram attribute. If you change the order of arguments, ProPCV does not prevent the execution of StartProgram. This causes delay in detecting concurrency violation.

For example, a single command can be run in multiple ways:

```
/usr/bin/tar -c -f a.tar
```

```
/usr/bin/tar -f a.tar -c
```

So, ProPCV does not function if you run the command in a way that is not configured in the StartProgram attribute.

- You must start the StartProgram by using the commands or the way specified in StartProgram attribute. But if you use another way or command to start the

program that is not specified in the attribute, ProPCV does not prevent the startup of the program. This causes delay in detecting concurrency violation.

- If StartProgram is a script, the script must have the interpreter path as the first line and start with #!.  
For example, a shell script should start with "#!/usr/bin/sh".
- If the StartProgram is a script, do not change the interpreter path in the script file after the StartProgram is registered for offline monitoring. Else, ProPCV may not function for the StartProgram.
- You must not append the StartProgram attribute with the special character &. For example, '/app/start.sh &'.

## Requirement for programs

The programs specified in StartProgram, StopProgram, MonitorProgram, CleanProgram should not continuously write to STDOUT or STDERR. If required, please redirect STDOUT and STDERR to some file.

## Requirement for default profile

The default profile of configured user should not have any blocking command such as `bash` or any other command such as `exec` that changes the behavior of the shell. This may lead to unexpected behavior.

## Sample configurations for Application agent

The sample configurations for this agent follow:

### Configuration 1 for Application agent

In this example, you configure the executable `sample_app` as StartProgram and StopProgram, with start and stop specified as command line arguments respectively. Configure the agent to monitor two processes: a process that the `app.pid` specifies and the process `sample_app`.

```
Application samba_app (  
  User = "root"  
  StartProgram = "/usr/sbin/sample_app start"  
  StopProgram = "/usr/sbin/sample_app stop"  
  PidFiles = { "/var/lock/sample_app/app.pid" }  
  MonitorProcesses = { "sample_app" }  
)
```

## Configuration 2 for Application agent

In this example, since no user is specified, it uses the root user. The executable `sample_app` starts and stops the application using `start` and `stop` as the command line arguments. The executable `sample_app_monitor` monitors the application and uses `all` as its command line argument. The agent also monitors the `sample_app1` and `sample_app2` processes.

```
Application samba_app2 (  
  StartProgram = "/usr/sbin/sample_app start"  
  StopProgram = "/usr/sbin/sample_app stop"  
  CleanProgram = "/usr/sbin/sample_app force stop"  
  MonitorProgram = "/usr/local/bin/sample_app_monitor all"  
  MonitorProcesses = { "sample_app1", "sample_app2" }  
)
```

## Configuration 3 for Application agent

In this example, configure a resource in a non-global zone: `zone1`. The `ZonePath` of `zone1` is `/zone1/root`. Configure the executable `samba` as `StartProgram` and `StopProgram`, with `start` and `stop` specified as command line arguments respectively. Configure the agent to monitor two processes: a process that the `smbd.pid` specifies and the process `nmbd`.

```
Application samba_app (  
  StartProgram = "/usr/sbin/samba start"  
  StopProgram = "/usr/sbin/samba stop"  
  PidFiles = { "/var/lock/samba/smbd.pid" }  
  MonitorProcesses = { "nmbd" }  
)
```

## Debug log levels for Application agent

The Application agent uses the following debug log levels:

DBG\_1, DBG\_2, DBG\_3, DBG\_4, DBG\_5

## CoordPoint agent

Use the Coordination Point (CoordPoint) agent to monitor the registrations on the different coordination points on each node.

In addition, the CoordPoint agent monitors changes to the Coordinator Disk Group constitution, such as when a disk is accidentally deleted from the Coordinator Disk Group or if the VxVM private region of a disk is corrupted.

The agent performs detailed monitoring on the CoordPoint resource. You can tune the frequency of the detailed monitoring with the `LevelTwoMonitorFreq` attribute. For example, if you set this attribute to 5, the agent monitors the Coordinator Disk Group constitution in every fifth monitor cycle.

The CoordPoint agent is a monitor-only agent that runs on each node within the client cluster. It can monitor Coordination Point (CP) servers and SCSI-3 disks.

## Coordination Point server as a coordination point

When you have configured a CP server as a coordination point, the CoordPoint agent performs the following tasks:

- Confirms that the CP server coordination point can communicate with the client cluster.
- Validates the node registrations in the CP server database using the `cpsadm` command.

## SCSI-3 based disk as a coordination point

In case the coordination point is a SCSI-3 based disk, the CoordPoint agent uses the `vxfsenadm` command to confirm that the registered keys on the disk are intact. The Monitor agent function contains the monitoring functionality for SCSI-3 disks and CP servers.

If the agent detects an anomaly, the agent reports it to you so you can repair the coordination point. You may have to perform an online coordinator point replacement procedure if the problem is isolated to the keys registered.

---

**Note:** The CoordPoint agent that runs on a given client cluster node monitors the keys for coordination points visible to that node alone.

---

For important information about this agent, refer to:

See [“Notes for the CoordPoint agent”](#) on page 206.

## Dependencies

No dependencies exist for the CoordPoint resource.

## Agent functions

Monitor	<p>Enables the CoordPoint agent to validate the node registrations in the coordination points and confirms that the coordination points are accessible. In addition, enables the agent to monitor disks in the Coordinator Disk Group. Specifically, if a disk is deleted from the disk group or the VxVM private region of a disk is corrupted.</p> <p>CoordPoint resources are persistent, which means that they cannot be brought online or taken offline. They can only monitor the coordination point registrations. For this reason, the service group that contains the CoordPoint resource appears to be offline after a command such as <code>hastatus -sum</code>.</p> <p>The CoordPoint agent also performs I/O fencing reporting activities. See <a href="#">“CoordPoint agent I/O fencing reporting activities”</a> on page 207.</p>
---------	---

## State definitions

ONLINE	Indicates that the CoordPoint resource is working.
UNKNOWN	Indicates the agent cannot determine the coordination points resource's state. This state may be due to an incorrect configuration.
FAULTED	<p>Indicates that CoordPoint resource is reported for one or more of the following conditions:</p> <ul style="list-style-type: none"><li>■ The number of coordination points with missing keys (or registrations) has exceeded the value of the FaultTolerance attribute.</li><li>■ The number of unreachable coordination points.</li><li>■ Coordinator disks are deleted from the Coordinator Disk Group.</li><li>■ Public character path of a disk and the device path that corresponds to the device number of that disk in the kernel driver do not match.</li></ul>

## Attributes

**Table 5-7** Required attributes

Required attribute	Description
FaultTolerance	<p>The FaultTolerance attribute determines when the CoordPoint agent declares that the registrations on the coordination points are missing or connectivity between the nodes and the coordination points is lost.</p> <p>If the number of coordination points with missing keys (or registrations) and or the number of unreachable coordination points exceeds the value of the FaultTolerance attribute, then the agent reports FAULTED.</p> <p>Set the value of this attribute depending on your own configuration requirements. For example, if the FaultTolerance value is set to 1, then the CoordPoint agent reports FAULTED if it sees 2 or more number of coordinator points with missing keys (or registrations) and or the number of unreachable coordination points.</p> <p>Change the value of the FaultTolerance attribute either before the CoordPoint agent starts to monitor or while the CoordPoint agent is monitoring. If the attribute is set while the CoordPoint agent is monitoring, then the CoordPoint agent reads the new value in the next monitor cycle.</p> <p>To view the current FaultTolerance value, enter the following command:</p> <pre># hares -display coordpoint -attribute FaultTolerance</pre> <p>Type and dimension: integer-scalar</p> <p>Default: "0"</p>

## Resource type definition

```
type CoordPoint (
    static str ArgList[] = { FaultTolerance }
    static int InfoInterval = 300
    static int OfflineMonitorInterval = 60
    static str Operations = None
    int FaultTolerance
)
```

## Notes for the CoordPoint agent

The notes are as follows:

## CoordPoint agent I/O fencing reporting activities

The CoordPoint agent also performs the following I/O fencing reporting activities:

- Checks to determine if I/O fencing is running.  
If I/O fencing is not running, then the CoordPoint agent reports failure.
- Checks the mode of fencing operation. I/O fencing can operate in one of the following three modes:
  - SCSI-3 mode: If I/O fencing runs in SCSI-3 mode, then the CoordPoint agent continues to monitor.
  - Customized mode: If I/O fencing runs in Customized Fencing mode, then the CoordPoint agent continues to monitor.
  - Disabled mode: If I/O fencing runs in disabled mode, no action is required. The CoordPoint agent returns success.

## AutoStartList attribute

AutoStartList is a service group attribute that needs to be populated with a system list. The VCS engine brings up the specified service group on the nodes in the list.

AutoStartList is not a required attribute for the service group that contains the CoordPoint resource. The CoordPoint resource is a persistent resource and when a service group is configured with this type of resource, it cannot be brought online.

Specifying the AutoStartList with a system list does not change the behavior of the service group. The service group will be reflected in OFFLINE status itself, irrespective of the AutoStartList attribute.

## Detailed monitoring for the Coordpoint resource

The agent fetches disk names and unique identifiers from the kernel driver for I/O fencing. It runs a series of commands on the disks for information such as disk access name. It checks for disks that are no longer part of the Coordinator Disk Group. It also compares the public character path of the disks with the device path stored in the kernel driver. The agent faults the resource when any of the checks fail.

## Sample configuration

In this example, the coordination point agent type resource is configured with the value of the FaultTolerance attribute set to 0. At this value setting, the CoordPoint agent reports FAULTED, when the agent determines that at least one coordination point has keys (or registrations) missing and or one coordination point is not reachable.

The following is an example service group (vxfen) extracted from a main.cf file:

```
group vxfen (
  SystemList = { sysA = 0, sysB = 1 }
  AutoFailOver = 0
  Parallel = 1
  AutoStartList = { sysA, sysB }
)
  CoordPoint coordpoint (
    FaultTolerance=0
    LevelTwoMonitorFreq = 5
  )
  // resource dependency tree
  //
  //   group vxfen
  //   {
  //   CoordPoint coordpoint
  //   }
```

## Debug log levels

The CoordPoint agent uses the following debug log levels:

DBG\_10

## Process agent

The Process agent starts, stops, and monitors a process that you specify. You can use the agent to make a process highly available.

This agent is Intelligent Monitoring Framework (IMF)-aware and uses asynchronous monitoring framework (AMF) kernel driver for IMF notification. For more information about IMF and intelligent resource monitoring, refer to the *Veritas Cluster Server Administrator's Guide*.

This agent is zone-aware. The ContainerOpts resource type attribute for this type has a default value of 1 for RunInContainer and a default value of 0 for PassCInfo. Symantec recommends that you do not change these values.

For more information on ContainerOpts attribute refer to the *Storage Foundation High Availability Virtualization Guide*.



## High availability fire drill for Process agent

The high availability fire drill detects discrepancies between the VCS configuration and the underlying infrastructure on a node; discrepancies that might prevent a service group from going online on a specific node.

For Process resources, the high availability fire drill checks for:

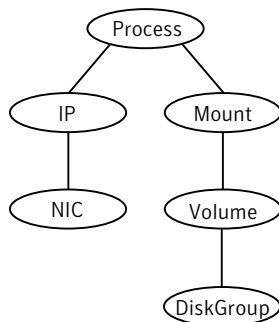
- The existence of a binary executable for the specified process (program.vfd)
- The existence of the same binary on all nodes (program.vfd)

For more information refer to the *Veritas Cluster Server Administrator's Guide*.

## Dependencies for Process agent

Depending on the context, this type of resource can depend on IP, IPMultiNIC, IPMultiNICB, Zone, and Mount resources.

**Figure 5-3** Sample service group for a Process resource



## Agent functions for Process agent

Online	Starts the process with optional arguments.
Offline	Terminates the process with a <code>SIGTERM</code> . If the process does not terminate, a <code>SIGKILL</code> is sent.
Monitor	Checks to see if the process is running by scanning the process table for the name of the executable pathname and argument list.
Clean	Terminates all ongoing resource actions and takes the resource offline, forcibly when necessary.

imf_init	Initializes the agent to interface with the asynchronous monitoring framework (AMF) kernel driver. This function runs when the agent starts up.
imf_getnotification	Gets notification about resource state changes. This function runs after the agent initializes with the AMF kernel driver. The agent continuously waits for notification and takes action on the resource upon notification.
imf_register	Registers the resource entities, which the agent must monitor, with the AMF kernel driver. For example, the function registers the PID for online monitoring of a process. This function runs for each resource after the resource goes into steady state (online or offline).

## State definitions for Process agent

ONLINE	Indicates that the specified process is running.  The agent only reports the process as online if the value configured for PathName attribute exactly matches the process listing from the ps output along with the arguments.
OFFLINE	Indicates that the specified process is not running.
FAULTED	Indicates that the process has terminated unexpectedly.
UNKNOWN	Indicates that the agent can not determine the state of the process.

## Attributes for Process agent

**Table 5-8** Required attribute

Required attribute	Description
PathName	<p>Absolute path to access an executable program. This path includes the program name. If a script controls the process, the PathName defines the complete path to the shell.</p> <p>This attribute must not exceed 80 characters.</p> <p>Type and dimension: string-scalar</p> <p>Example: "/usr/lib/sendmail"</p>

**Table 5-9** Optional attributes

Optional attribute	Description
Arguments	<p>Passes arguments to the process. If a script controls the process, the script is passed as an argument. Separate multiple arguments with a single space. A string cannot accommodate more than one space between arguments, nor allow for leading or trailing whitespace characters.</p> <p>This attribute must not exceed 80 characters.</p> <p>Type and dimension: string-scalar</p> <p>Example: "-bd -q15m"</p>

## Resource type definition for Process agent

```

type Process (
  static keylist SupportedActions = { "program.vfd", getcksum }
  static str ArgList[] = { PathName, Arguments }
  static int ContainerOpts{} = { RunInContainer=1, PassCInfo=0 }
  str PathName
  str Arguments
)

```

## Usage notes for Process agent

The Process agent has the following notes:

- [Requirement for programs](#)

### Requirement for programs

The programs specified in PathName should not continuously write to STDOUT or STDERR. If required, please redirect STDOUT and STDERR to some file.

## Sample configurations for Process agent

### Configuration 1 for Process agent

Configuration 1 for Solaris follows:

```

Process usr_lib_sendmail (
  PathName = "/usr/lib/sendmail"
)

```

```
Arguments = "-bd -q15m"
)
```

## Configuration 2 for Process agent

Configuration 2 follows:

```
include "types.cf"
cluster ProcessCluster (
.
.
.
group ProcessGroup (
SystemList = { sysa = 0, sysb = 1 }
AutoStartList = { sysa }
)
Process Process1 (
PathName = "/usr/local/bin/myprog"
Arguments = "arg1 arg2"
)
Process Process2 (
PathName = "/bin/csh"
Arguments = "/tmp/funscript/myscript"
)
// resource dependency tree
//
// group ProcessGroup
// {
// Process Process1
// Process Process2
// }
```

## Debug log levels for Process agent

The Process agent uses the following debug log levels:

```
DBG_1, DBG_4, DBG_5
```

## ProcessOnOnly agent

The ProcessOnOnly agent starts and monitors a process that you specify. You can use the agent to make a process highly available or to monitor it. This resource's Operation value is OnOnly.

This agent is zone-aware. The ContainerOpts resource type attribute for this type has a default value of 1 for RunInContainer and a default value of 0 for PassCInfo. Symantec recommends that you do not change these values.

Refer to the *Storage Foundation High Availability Virtualization Guide*.

VCS uses this agent internally to monitor security processes in a secure cluster.

## Dependencies

No child dependencies exist for this resource.

## Agent functions

Online	Starts the process with optional arguments.
Monitor	Checks to see if the process is alive by scanning the process table for the name of the executable pathname and argument list.
Clean	Terminates all ongoing resource actions and takes the resource offline, forcibly when necessary.

## State definitions

ONLINE	Indicates that the specified process is running.  The agent only reports the process as ONLINE if the value configured for PathName attribute exactly matches the process listing from the ps output along with the arguments.
FAULTED	Indicates that the process has unexpectedly terminated.
UNKNOWN	Indicates that the agent can not determine the state of the process.

## Attributes

**Table 5-10** Required attributes

Required attribute	Description
PathName	<p>Defines complete pathname to access an executable program. This path includes the program name. If a process is controlled by a script, the PathName defines the complete path to the shell. Pathname must not exceed 80 characters.</p> <p>The value configured for this attribute needs to match the process listing from the ps output for the agent to display as ONLINE.</p> <p>Type and dimension: string-scalar</p> <p>Example:</p> <p>"/usr/lib/nfs/nfsd"</p>

**Table 5-11** Optional attributes

Optional attribute	Description
Arguments	<p>Passes arguments to the process. If a process is controlled by a script, the script is passed as an argument. Multiple arguments must be separated by a single space. A string cannot accommodate more than one space between arguments, nor allow for leading or trailing whitespace characters. Arguments must not exceed 80 characters (total).</p> <p>Type and dimension: string-scalar</p> <p>Example: "- a 8"</p>
IgnoreArgs	<p>A flag that indicates whether monitor ignores the argument list.</p> <ul style="list-style-type: none"> <li>■ If the value is 0, it checks the process pathname and argument list.</li> <li>■ If the value is 1, it only checks for the executable pathname and ignores the rest of the argument list.</li> </ul> <p>Type and dimension: boolean-scalar</p> <p>Default: 0</p>

## Resource type definition

```
type ProcessOnOnly (
    static str ArgList[] = { IgnoreArgs, PathName, Arguments }
```

```
static int ContainerOpts{} = { RunInContainer=1, PassCInfo=0 }
static str Operations = OnOnly
boolean IgnoreArgs = 0
str PathName
str Arguments
)
```

## ProcessOnOnly agent usage notes

The ProcessOnOnly agent has the following notes:

- [Requirement for programs](#)

### Requirement for programs

The programs specified in PathName should not continuously write to STDOUT or STDERR. If required, please redirect STDOUT and STDERR to some other file.

## Sample configurations

```
group VxSS (
SystemList = { north = 0, south = 1 }
Parallel = 1
AutoStartList = { north, south }
OnlineRetryLimit = 3
OnlineRetryInterval = 120
)
Phantom phantom_vxss (
)
ProcessOnOnly vxatd (
IgnoreArgs = 1
PathName = "/opt/VRTSat/bin/vxatd"
)
```

## Debug log levels

The ProcessOnOnly agent uses the following debug log levels:

DBG\_1

## Zone agent

The Zone agent brings online, takes offline, monitors, and cleans Solaris zones. You can use the agent to make zones highly available and to monitor them.

The ContainerOpts resource type attribute for this type has a default value of 0 for RunInContainer and a default value of 1 for PassCInfo. Symantec recommends that you do not change the values for these keys.

On Oracle Solaris 10, Solaris 10 native zones are supported.

On Oracle Solaris 11, solaris11 and solaris10 brand zones are supported.

This agent is IMF-aware and uses asynchronous monitoring framework (AMF) kernel driver for IMF notification. For more information about the Intelligent Monitoring Framework (IMF) and intelligent resource monitoring, refer to the *Veritas Cluster Server Administrator's Guide*.

---

**Note:** When zone goes into maintenance state, AMF does not detect the state. The change in state is detected by Zone monitor in the next cycle.

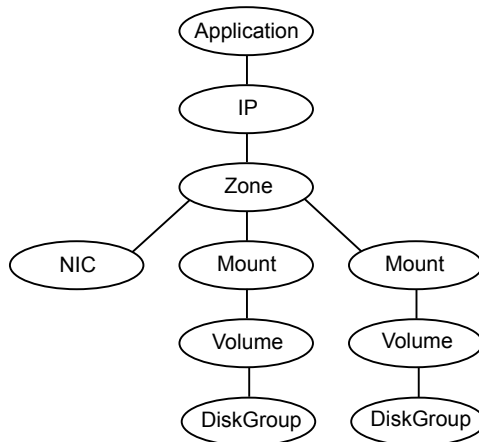
---

Refer to the *Storage Foundation High Availability Virtualization Guide* for more information.

## Dependencies

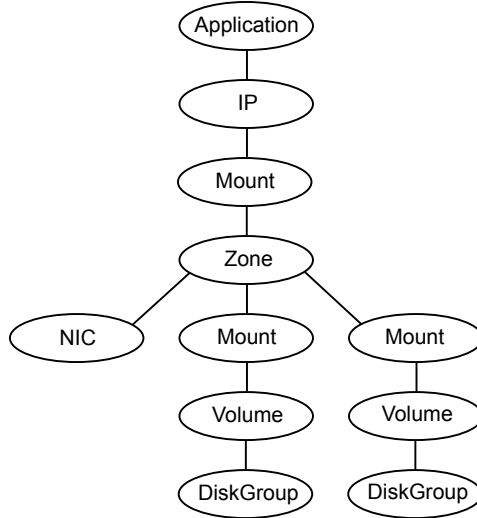
Typically no dependencies are required for the Zone resource, however if the zone root is on shared storage the resource may require the Mount and DiskGroup resources.

**Figure 5-4** Sample service group that includes a Zone resource when the zone root is on shared storage with a loopback file system. The loopback file system is mounted inside the zone using the zonecfg command

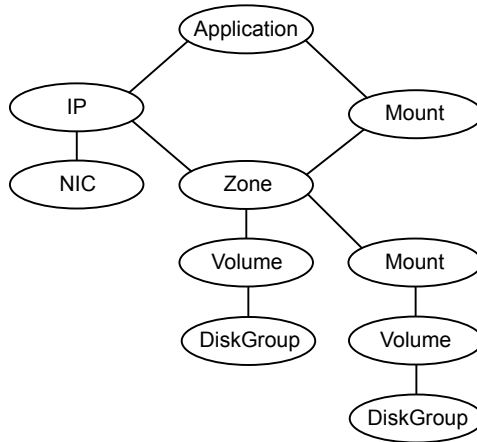




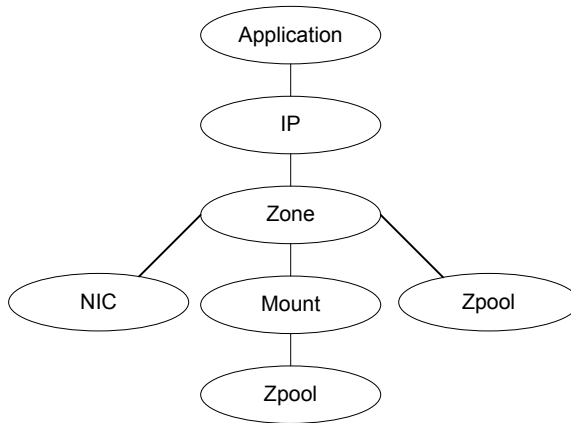
**Figure 5-5** Sample service group that includes a Zone resource for the zone root on shared storage with a loopback file system when VCS manages the loopback file system as a Mount resource



**Figure 5-6** Sample service group that includes a Zone resource with the zone root on shared storage a direct mounted file system



**Figure 5-7** Sample service group that includes a Zone resource with the zone root on ZFS shared storage monitored by Zpool resource



## Agent functions

Online	Brings a non-global zone up and running.
Offline	Takes a non-global zone down.
Monitor	Checks if the specified non-global zone is up and running.  If IMF is enabled for the Zone agent, the resource is monitored asynchronously and any change in the resource state is immediately sent to VCS for appropriate action.
imf_init	Initializes the agent to interface with the asynchronous monitoring framework (AMF) kernel driver. This function runs when the agent starts up.
imf_getnotification	Waits for notification about resource state changes. This function runs after the agent initializes with the AMF kernel driver. The agent continuously waits for notification and takes action on the resource upon notification.
imf_register	Registers the resource entities, which the agent must monitor, with the AMF kernel driver. This function runs for each resource after the resource goes into steady state (online or offline)
Clean	A more forceful method for halting a non-global zone.

## Attributes

**Table 5-12** Optional attributes for Solaris

Optional attribute	Description
Pool	This is the resource pool name that is associated with the zone. Type and dimension: string-scalar
BootState	The value for the milestone service. Acceptable values follow: <ul style="list-style-type: none"><li>■ single-user</li><li>■ multi-user</li><li>■ multi-user-server</li></ul> <b>Note:</b> Symantec recommends that you use the multi-user-server value for the BootState attribute. Type and dimension: string-scalar Default: multi-user
ShutdownGracePeriod	Specifies the interval in seconds from the Offline action to the execution of the shutdown within the zone. Type and dimension: integer-scalar Default: 0 Example: "10"
RunFsck	If the value of this attribute is 1, the Zone agent checks file system consistency for vxfs file systems. It uses the fsck -y command on all vxfs file systems that are defined in the zone's xml file. This file is located in /etc/zones. Adjust the Zone agent default OnlineTimeout value so that zone agent has sufficient time to run the fsck command before it brings the zone online. Type and dimension: boolean-scalar Default: 0 Example: 1
DetachZonePath	If disabled, the Zone agent skips detaching the Zone root during zone resource offline and clean. DetachZonePath is enabled (1) by default. Type and dimension: boolean-scalar Default: 1 Example: 0

**Table 5-12** Optional attributes for Solaris (*continued*)

Optional attribute	Description
ForceAttach	<p>If disabled, the Zone agent attaches the ZonePath without the -F option during zone resource online. ForceAttach is enabled (1) by default.</p> <p>Type and dimension: boolean-scalar</p> <p>Default: 1</p> <p>Example: 0</p>
DeleteVCSZoneUser	<p>If enabled on a non-secure cluster Zone agent deletes the VCS Zone user created for password-less communication between local-zone and global zone, during offline and clean entry points. DeleteVCSZoneUser is disabled by default.</p> <p>Type and dimension: boolean-scalar</p> <p>Default: 0</p>

**Table 5-12** Optional attributes for Solaris (*continued*)

Optional attribute	Description
DROpts	

Table 5-12 Optional attributes for Solaris (*continued*)

Optional attribute	Description
	<p>The value of this attribute consists of the following keys that define the disaster recovery (DR) options for the Zone.</p> <ul style="list-style-type: none"> <li>■ <b>DNSDomain</b> The domain name to use within the Zone at this site.</li> <li>■ <b>DNSSearchPath</b> The domain search path used by this Zone at this site. The value of this key must contain a list of DNS domain names that are used for the DNS lookup of a hostname in case the domain name of the hostname is not specified. Use spaces to separate the domain names.</li> <li>■ <b>DNSServers</b> The list of DNS servers used by this Zone at this site. The value of this key must contain a list of IP addresses of DNS servers that are used for the DNS lookup of a hostname. Use spaces to separate the IP addresses.</li> <li>■ <b>Gateway</b> The default gateway used by this Zone at this site.</li> </ul> <p>The following additional keys can be set for the exclusive IP zones:</p> <ul style="list-style-type: none"> <li>■ <b>Device</b> The Network Interface Card (NIC) that is dedicated to the exclusive IP zone in this site. If this key not specified, the agent automatically selects the first dedicated NIC for the assignment of IP address, if specified</li> <li>■ <b>IPAddress</b> The IP address to be assigned to an exclusive IP zone at this site after a cross-site failover. The agent writes the IP address inside the Zone Root in the file <code>/etc/hostname.Device</code> where Device is the value of Device key.</li> <li>■ <b>Netmask</b> The netmask to be used in an exclusive IP zone at this site after a cross-site failover. The agent writes the netmask inside the Zone Root in the file <code>/etc/netmasks.</code></li> <li>■ <b>Hostname</b> The hostname to be used for an exclusive IP zone in this site. If specified, the agent writes the IPAddress in the file <code>/etc/hosts</code> and then writes the hostname in the file <code>/etc/hostname.Device.</code> where Device is the value of Device</li> </ul>

**Table 5-12** Optional attributes for Solaris (*continued*)

Optional attribute	Description
	<p>key</p> <p>In a DR configuration, if one or more of these keys are set, the resource is considered to be DR-enabled. If all the keys stay at their default value (""), then the resource is not DR-enabled even if it is in a disaster recovery configuration.</p> <p>Type and dimension: string-association</p>

## Configuring the Zone agent for DR in a Global Cluster environment

For information about configuring the Zone agent for DR in a Global Cluster environment, refer to the *Veritas Storage Foundation and High Availability Solutions Virtualization Guide*.

## Resource type definition

```

type Zone (
  static str ArgList[] = { Pool, BootState,
  ShutdownGracePeriod, RunFsck, DetachZonePath, ForceAttach,
  DeleteVCSZoneUser, DROpts }
  static boolean AEPTIMEOUT = 1
  static str IMFRegList[] = { BootState }
  static str IMF{} = { Mode = 3, MonitorFreq = 5,
  RegisterRetryLimit = 3 }
  static int ContainerOpts{} = { RunInContainer=0, PassCInfo=1 }
  str Pool
  str BootState = multi-user
  int ShutdownGracePeriod
  boolean RunFsck = 0
  boolean DetachZonePath = 1
  boolean ForceAttach = 1
  boolean DeleteVCSZoneUser = 0
  str DROpts{}
)

```

## Zone agent notes

The Zone agent has the following notes:

- See [“Using the Zone agent with IMF”](#) on page 224.

## Using the Zone agent with IMF

If you use IMF for intelligent resource monitoring, review the following recommendations.

- Set the value of the MonitorFreq key to a high value to ensure that the agent does not run the traditional monitor function frequently.
- Monitor the health of the storage, on which the zone root is created, using one of the storage agents such as Mount, Zpool, or Volume. The Zone agent should have a dependency on the storage agent as depicted in [Dependencies](#).
- The Zpool agent is not IMF aware. Hence, if the Zpool agent is used to monitor the zone root mount point, then no instantaneous notification will be received in case the zone root mount point is un-mounted externally. Still, traditional monitoring of Zpool will detect failure of the mount point.
- When you run the `svcadm` command to update the state of a service, outside of VCS control, IMF notifies the Zone agent. If IMF falsely notifies about an update to the state of the service group, the state of the resource does not change. Thereafter, the Zone agent reregisters events with IMF.

---

**Note:** With the zone agent registered to IMF for Online or Offline monitoring, if the IMF notification to the Zone agent is false, agent framework schedules the zone monitor. Zone monitor verifies and confirms that there is no change in the state of the resource. Thereafter, Zone agent reregisters the events with IMF.

---

- Zone agent registered to IMF for Directory Online event  
The Directory Online event monitors the Zone root directory. If the parent directory of the Zone root directory is deleted or moved to another location, IMF does not provide notification to the Zone agent. In the next cycle of the zone monitor, it detects the change and reports the state of the resource as offline.

## Sample configurations

The sample configuration for the Zone agent follows:

### Application resource in a non-global zone for Solaris 10

In this example, configure a resource in a non-global zone: localzone1. The ZonePath of localzone1 is /zone1/root. The ContainerInfo attribute for this service group is set to ContainerInfo = { Name = "localzone1", Type = "Zone", Enabled = 1}. Configure the executable samba as StartProgram and StopProgram, with start and stop specified as command line arguments respectively. Configure the agent



to monitor two processes: a process specified by the pid `smbd.pid`, and the process `nmbd`.

```
include "types.cf"
cluster vcszones_clus (
UserNames = { admin = eHIaHChEIdIIgQIcHF,
z_zone_res_sys1 = dKLeIOjQJjJTjSKsHK }
Administrators = { admin }
)
system sys1 (
)
system sys2 (
)
group zoneapp_grp (
SystemList = { sys1 = 0, sys2 = 1 }
ContainerInfo = { Name = localzone1, Type = Zone, Enabled =1 }
AutoStartList = { sys1 }
Administrators = { z_zone_res_sys1 }
)
Application samba_app (
StartProgram = "/usr/sbin/samba start"
StopProgram = "/usr/sbin/samba stop"
PidFiles = { "/localzone1/root/var/lock/samba/smbd.pid" }
MonitorProcesses = { "nmbd" }
)
Zone zone_res (
)
samba_app requires zone_res
// resource dependency tree
//
// group grp_sol10zone
// {
// Application samba_app
// {
// Zone zone_res
// }
// }
```

## Debug log levels

The Zone agent uses the following debug log levels:

DBG\_1, DBG\_2, DBG\_3, DBG\_4, DBG\_5

## LDom agent

The LDom agent brings Logical domain (LDom) online, takes them offline, and monitors them in Oracle VM server for SPARC environment. You can use this agent to monitor LDomS and to make them highly available.

For detailed information about support for logical domains, refer to the *Storage Foundation High Availability Virtualization Guide*.

## Configuring primary and guest domain dependencies and failure policy

For all the guest domains that are configured in the cluster, the agent performs the following commands to set:

- The dependency between the primary and guest domains.  

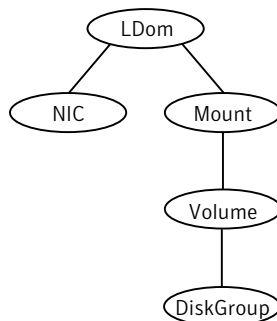
```
# ldm set-domain master=primary guestldom
```
- The failure-policy of the primary domain to stop.  

```
# ldm set-domain failure-policy=stop primary
```

## Dependencies

The LDom resource depends on the NIC resource. It also depends on a storage resource, such as Mount, Volume, DiskGroup, Zpool, or Disk.

**Figure 5-8** Sample service group for an LDom resource that monitors an image file



### Network resources

Use the NIC agent to monitor the network adapter for the LDom, whether it is virtual or physical.

## Storage resources

- Veritas Volume Manager (VxVM) exposed volumes  
Use the Volume and DiskGroup agents to monitor a VxVM volume.
- ZFS volumes  
Use the Zpool agent to monitor a ZFS volume.
- Disk or LUN  
Use Disk agent to monitor Disk or LUN
- Image file
  - Image file in a volume that is managed by Veritas Volume Manager (VxVM)  
Use the Mount, Volume, and DiskGroup agents to monitor the image file.
  - Image file in an NFS share  
Use the Mount agent to monitor the image file.
  - Image file in a ZFS volume  
Use the Mount and Zpool agents to monitor the image file.
  - Image file in a partition of a physical disk  
Use the Mount and Disk agents to monitor the image file.

## Agent functions

Online	Starts the LDom.
Offline	Stops the LDom.
Monitor	Monitors the status of the LDom.
Clean	Stops the LDom forcefully.

## State definitions

ONLINE	Indicates that the LDom is up and running.
OFFLINE	Indicates that the LDom is down.
FAULTED	Indicates that the LDom is down when the VCS engine expects it to be up and running.  If the MonitorCPU attribute is set to true (1), CPU usage of either 0% or 100% is interpreted as a fault.
UNKNOWN	Indicates the agent cannot determine the LDom's state. A configuration problem likely exists in the resource or the LDom.

## Attributes

[Table 5-13](#) summarizes the required attributes for the LDom agent.

**Table 5-13** Required attributes for Solaris

Required attribute	Description
LDomName	The name of the LDom that the user wants to monitor. Type-dimension: string-scalar Default: n/a Example: "ldom1"

[Table 5-14](#) summarizes the optional attributes for the LDom agent.

**Table 5-14** Optional attributes for Solaris

Optional attribute	Description
CfgFile	<p>The absolute path of the XML file that contains the LDom configuration. To create the configuration file for an LDom, run the following command:</p> <pre>\$ ldm list-constraints -x ldom_name &gt; ldom_name.xml</pre> <p>If this attribute is configured, LDom agent uses this file to create LDom when LDom configuration is not found on a node. Make sure that default services like virtual disk server(vds), virtual switch service(vsw), virtual console concentrator service(vcc) are already created on all the nodes to use the xml file.</p> <p>If domain migration is planned for the LDom, then this attribute must be configured.</p> <p>Refer to the <i>ldm(1M) man page</i> for information on this file.</p> <p>The configuration file must be present locally on all of the systems or on a shared disk where it is accessible by all of the systems.</p> <p>Type-dimension: string-scalar Default: n/a Example: "/root/ldom-cfg/ldom1.xml"</p>

**Table 5-14** Optional attributes for Solaris (*continued*)

Optional attribute	Description
MonitorCPU	<p>Specifies whether the LDom agent monitors the CPU usage of the LDom.</p> <p>If the CPU usage of all of the VCPUs attached to the LDom is equal to either 0% or 100%, then the resource is declared FAULTED.</p> <p>For an LDom with one VCPU, set this attribute to 0. This setting is to work around an LDom limitation where an LDom with one VCPU always reports CPU usage of 100%.</p> <p>Type-dimension: boolean-scalar</p> <p>Default: 1</p>
NumCPU	<p>The number of virtual CPUs that you want to attach to the LDom when it is online. If you set this attribute to a positive value, the agent detaches all of the virtual CPUs when the service group goes offline. Do not reset this value to 0 after setting it to 1.</p> <p>If the agent's monitor entry point finds that the CPUs available to the LDom is less than the value of the NumCPU attribute, it logs a warning about the mismatch. It also sets ConfidenceMsg and ConfidenceLevel accordingly.</p> <p>This attribute can be modified while LDom is online to dynamically reconfigure virtual CPUs assigned to the LDom.</p> <p>Type-dimension: integer-scalar</p> <p>Default: 0</p>

**Table 5-14** Optional attributes for Solaris (*continued*)

Optional attribute	Description
Memory	<p>The amount of memory to be assigned to an LDom.</p> <p><b>Note:</b> The attribute will work for Oracle VM Server for SPARC version 2.0 or later only and for domains that support dynamic reconfiguration of memory.</p> <p>The expected value of this attribute is a positive integer followed by the unit G, M, or K, where G stands for gigabytes, M stands for megabytes, and K stands for kilobytes. The memory specified here will be governed by the --auto-adj option of the ldm set-memory command which enforces it to 256 Mbyte alignment.</p> <p>The success of the ldm set-memory command depends on the availability of the memory pool that is free.</p> <p>If the agent's monitor entry point finds that memory available to the LDom is less than the value of the Memory attribute, it logs a warning about the mismatch. It also sets ConfidenceMsg and ConfidenceLevel accordingly.</p> <p>This attribute can be modified while LDom is online to dynamically reconfigure memory assigned to the LDom.</p> <p>Type-dimension: string-scalar</p> <p>Default: Null Example: 4G</p> <p>Example: 2048M</p>
ConfigureNetwork	<p>Specifies if the LDom agent configures the network-bootarguments PROM variable of the guest domain. If the value of the attribute is set to 1, then the LDom agent updates the networkboot-arguments PROM variable using the following attributes: IPAddress, Netmask, Gateway, and DNS.</p> <p>Type and dimension: string-scalar</p> <p>Default: ""</p>
IPAddress	<p>During the online operation, the agent sets the value of this attribute to the host-ip key of the network-boot-arguments PROM variable of the LDom.</p> <p>Type and dimension: string-scalar</p> <p>Default: ""</p>

**Table 5-14** Optional attributes for Solaris (*continued*)

Optional attribute	Description
Netmask	During the online operation, the agent sets the value of this attribute to the subnet-mask key of the network-bootarguments PROM variable of the LDom.  Type and dimension: string-scalar  Default: ""
Gateway	During the online operation, the agent sets the value of this attribute to the router-ip key of the network-bootarguments PROM variable of the LDom.  Type and dimension: string-scalar  Default: ""
DNS	During the online operation, the agent sets the value of this attribute to the name-servers key of the network-bootarguments PROM variable of the LDom.  Type and dimension: string-scalar  Default: ""
RemoveLDomConfigForMigration	If enabled, agent removes the ldom configuration from the system during offline and clean operations provided CfgFile attribute is configured. User need to enable this attribute if domain migration is planned for the logical domain. This is because, domain migration can not be performed if logical domain configuration is present on target node for migration.  Type and dimension: boolean-scalar  Default:0  Example: 1

**Table 5-15** Resource type attribute

Optional attribute	Description
IntentionalOffline	<p>This attribute is required for performing domain migration.</p> <p>The value of this attribute must be set to 1 when performing domain migration.</p> <p>For information on how to use the IntentionalOffline resource type attribute, refer to the <i>Veritas Cluster Server Administrator's Guide</i>.</p> <p>Default: 1</p>
ResyncVMCfg	<p>The ResyncVMCfg attribute is set by the havmconfigsnc utility. If this attribute is set, the agent redefines the virtual machine configuration if it already exists using the CFgFile attribute.</p> <p><b>Note:</b> You must not set the ResyncVMCfg attribute manually.</p>

## Configuring the LDom agent for DR in a Global Cluster environment

For information about configuring the LDom agent for DR in a Global Cluster environment, refer to the *Veritas Storage Foundation and High Availability Solutions Virtualization Guide*.

## Resource type definition

```

type LDom (
    static keylist RegList = { NumCPU, Memory }
    static boolean IntentionalOffline = 1
    static keylist SupportedActions = { "vmconfigsnc" }
    static str AgentFile = "bin/Script51Agent"
    static str ArgList[] = { State, IState, LDomName,
        CfgFile, MonitorCPU, NumCPU, ConfigureNetwork, IPAddress,
        Netmask, Gateway, DNS ,Memory, CEInfo,
        RemoveLDomConfigForMigration, ResyncVMCfg }
    str CEInfo{} = { Enabled=0, CESystem=NONE, FaultOnHBLoss=1 }
    str LDomName
    int ConfigureNetwork
    str IPAddress
    str Netmask
    str Gateway

```



```
str DNS
str CfgFile
boolean MonitorCPU = 1
int NumCPU
str Memory
static boolean AEPTIMEOUT = 1
boolean RemoveLDomConfigForMigration = 0
boolean ResyncVMCfg = 0
)
```

## LDom agent notes

The LDom agent has the following notes:

- See [“About the auto-boot? variable”](#) on page 233.

## About the auto-boot? variable

Caution: Do not change the value of the auto-boot? variable to true.

Symantec recommends that you do not change the value of the auto-boot? variable to true. Changing the value to true can lead to data corruption in a scenario where the guest domain shares a disk in a cluster and the domain starts on more than one node.

## Sample configurations

Minimal LDom configuration

```
LDom ldom1 (
    LDomName = "ldom1"
)
```

## Sample configuration 2

```
group ldom_sg (
    SystemList = { sys1 = 0, sys2 = 1 }
)

LDom ldmres (
    LDomName = ldg1
)

DiskGroup dgres (
```

```
        DiskGroup = dg1
    )

    Volume volres (
        Volume = vol1
        DiskGroup = dg1
    )

    NIC nicres (
        Device = nxge3
    )

    ldmres requires volres
    ldmres requires nicres
    volres requires dgres
```

## Configuration (future LDom migration)

```
LDom ldom1 (
    LDomName = guest
    CfgFile = "/guest.xml"
    RemoveLDomConfigForMigration=1
)
```

## Debug log levels

The LDom agent uses the following debug log levels:

DBG\_1, DBG\_2, DBG\_3, DBG\_4, DBG\_5

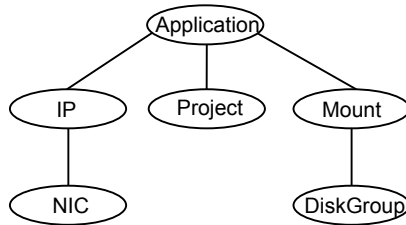
## Project agent

The Project agent adds, deletes, and monitors Solaris 10 projects. You can use the agent to make projects highly available or to monitor them.

## Dependencies

[Figure 5-9](#) shows a sample service group that includes a Project resource.

**Figure 5-9** Sample service group that includes a Project resource



## Agent functions

Online	Creates a Solaris project, if one is not present. Modifies a Solaris project, if one present.
Offline	Deletes a Solaris project if the value of the OfflineDelProject attribute is 1. If the value of the OfflineDelProject attribute is 0, then the Solaris project is not deleted from the /etc/project file.
Monitor	Checks if the specified project exists in /etc/project file.
Clean	Deletes a Solaris project if the value of the OfflineDelProject attribute is 1. If the value of the OfflineDelProject attribute is 0, then the Solaris project is not deleted from the /etc/project file.

## Attributes

**Table 5-16** Required attributes

Required attribute	Description
OfflineDelProject	<p>Use the OfflineDelProject attribute to tell the Project agent to remove a project entry from the /etc/project file when the agent invokes the offline or clean agent functions.</p> <p>The OfflineDelProject's default value is 1, which instructs the Project agent to remove the project's entry from the /etc/project file.</p> <p>Set the value of the OfflineDelProject's attribute to 0, if you do not want the project to be deleted from the /etc/project file.</p> <p>Default: 1</p>

**Table 5-17** Optional attributes

Optional attribute	Description
User	Comma separated list of existing users that are part of the project. Type and dimension: string-scalar

## Resource type definition

```

type Project (
  static str ArgList[] = { User, OfflineDelProject }
  static int ContainerOpts() = { RunInContainer=0, PassCInfo=1 }
  static int FaultPropagation = 0
  str User
  boolean OfflineDelProject = 1
)

```

## Sample configuration

```

include "types.cf"
include "OracleTypes.cf"
cluster vcs (
)
group grp_xrm (
  SystemList = { sysa = 0 }
  ContainerInfo @sysa = { Name = ora_project, Type = XRM,
  Enabled = 1 }
)
Oracle ora_res (
  Sid = oradb
  Owner = oracle
  Home = "/oraHome/app"
)
Project proj_res (
  User = oracle
  OfflineDelProject = 0
)
ora_res requires proj_res
// resource dependency tree
//
// group grp_xrm
// {

```

```
// Oracle ora_res  
// {  
// Project proj_res  
// }  
// }
```

## Debug log levels

The Project agent uses the following debug log levels:

DBG\_1

## AlternatelIO agent

The AlternatelIO agent monitors VCS storage and network service groups that in turn monitor redundant I/O services exported from the control domain and alternate I/O domain to a guest logical domain.

The AlternatelIO agent functions when:

- Logical domain is managed by in Oracle VM Server for SPARC environment.
- Alternate I/O domains are configured to provide redundant storage and network services to the guest Logical Domain

The AlternatelIO agent provides consolidated status of storage and network connectivity to a guest logical domain from multiple I/O domains.

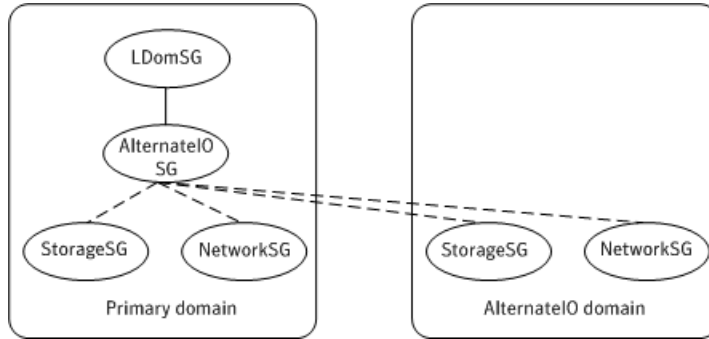
For detailed information on support for logical domains with alternate I/O domains, refer to the *Storage Foundation High Availability Virtualization Guide*.

## Dependencies for AlternatelIO agent

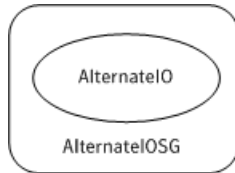
AlternatelIO resource does not directly depend on any other VCS resources.

However, the state of AlternatelIO resource depends upon the state of storage or network resources that are part of the service groups monitored by the AlternatelIO resource.

**Figure 5-10** shows a sample service group configuration with an AlternatelIO service group



**Figure 5-11** shows an AlternatelIO service group



## Agent functions for AlternatelIO agent

Online	Brings the storage and network service groups online if value in the key-value pair is set to 1.
Offline	Takes the storage and network service groups offline if value in the key-value pair is set to 1.
Monitor	Monitors the state of storage and network service groups. The resource shows online if all the storage and network service groups are online atleast on one of the domains - primary domain or alternate I/O domain.  The resource shows offline even if one of the storage or network service group is offline on the primary domain and the alternate I/O domain.
Clean	No function performed.

## State definitions for AlternatelIO agent

ONLINE	Reports an ONLINE state when all the storage service groups and network service groups are online atleast on one of the domains - on either the primary or alternate I/O domain.
--------	--

OFFLINE	Reports an OFFLINE state even if one of the storage service group or network service group is offline on the primary domain and the alternate I/O domain.
UNKNOWN	<p>Reports an UNKNOWN state for the service groups given in StorageSG and NetworkSG attributes in the following conditions:</p> <ul style="list-style-type: none"> <li>■ No service group is defined</li> <li>■ No service group has the SystemList attribute defined</li> <li>■ A service group is frozen temporarily or persistently</li> </ul>

## Attributes for AlternatelIO agent

**Table 5-18** Required Attributes

Required Attributes	Description
StorageSG	<p>A key-value pair with service groups that cater to the storage requirements of the guest domain managed by VCS as keys and option to online and offline these service groups as values. Set the value to 1 to online the service groups during online operation and offline the service group during offline operation.</p> <p>If the service group contains resources like zpool that need to be onlined during online operation of AlternatelIO resource, and offlined during online operation of AlternatelIO resource set the value to 1. If the service group contains resources like disks or CVM shared disk group that need not be to be onlined during online operation of AlternatelIO resource or offlined during online operation of AlternatelIO resource, set the value to 0.</p> <p>Type and dimension: string-vector</p> <p>Default: n/a</p> <p>Example: StorageSG = { sg_storage_ldom1 = 1 }</p>
NetworkSG	<p>A key-value pair with service groups that cater to the network requirements of the guest domain managed by VCS as keys and option to online or offline these service groups as values. Set the value to 1 to online the service groups during online operation and offline the service group during offline operation.</p> <p>In general, for service group containing resources to monitor network resources set value to zero.</p> <p>Type and dimension: string-vector</p> <p>Default: n/a</p> <p>Example: NetworkSG = { sg_network_ldom1 = 0 }</p>

## Resource type definition for AlternatelIO agent

```
type AlternateIO (
    static str AgentFile = "bin/Script51Agent"
    static str ArgList[] = { StorageSG, NetworkSG }
    str StorageSG{}
    str NetworkSG{}
)
```

## Sample configurations for AlternatelIO agent

A main.cf example that shows the AlternatelIO agent configuration.

```
include "types.cf"
cluster aioclus (
    UserNames = { admin = xxxxxxxxxxxx }
    Administrators = { admin }
    HacliUserLevel = COMMANDROOT
)
system primary1 (
)
system alternatel (
)
system primary2 (
)
system alternate2 (
)
group aiosg (
    SystemList = { primary1 = 0, primary2 = 1 }
    Parallel = 1
)
AlternateIO aiores1 (
    StorageSG @primary1 = { primary1-strsg = 0 }
    StorageSG @primary2 = { primary2-strsg = 0 }
    NetworkSG @primary1 = { primary1-nwsg = 0 }
    NetworkSG @primary2 = { primary2-nwsg = 0 }
)

// resource dependency tree
//
// group aiosg
```



```
// {  
// AlternateIO aiores1  
// }  
  
group ldmsg (  
  SystemList = { primary1 = 0, primary2 = 1 }  
)  
  
LDom ldmres (  
  LDomName = ldg1  
)  
  
requires group aiosg online local hard  
// resource dependency tree  
//  
// group ldmsg  
// {  
// LDom ldmres  
// }  
  
group primary1-nwsg (  
  SystemList = { primary1 = 0, alternatel = 1 }  
  Parallel = 1  
  AutoStartList = { primary1, alternatel }  
)  
NIC nicres (  
  Device @primary1 = nxge3  
  Device @alternatel = nxge1  
)  
Phantom ph1 (  
)  
// resource dependency tree  
//  
// group primary1-nwsg  
// {  
// Phantom ph1  
//   {  
//     NIC nicres  
//   }  
// }  
// }
```

```
group primary1-strsg (
  SystemList = { primary1 = 0, alternatel = 1 }
  Parallel = 1
  AutoStartList = { primary1, alternatel }
)
Disk disk1 (
  Partition @primary1 = "/dev/rdisk/c3t50060E8000C46C50d2s2"
  Partition @alternatel = "/dev/rdisk/c1t50060E8000C46C50d2s2"
)

Phantom ph2 (
)
// resource dependency tree
//
// group primary1-strsg
// {
//   Phantom ph2
//     {
//       Disk disk1
//     }
// }
group primary2-nwsg (
  SystemList = { primary2 = 0, alternate2 = 1 }
  Parallel = 1
  AutoStartList = { primary2, alternate2 }
)
NIC nicres1 (
  Device @primary2 = nxge3
  Device @alternate2 = nxge1
)
Phantom ph3 (
)
// resource dependency tree
//
// group primary2-nwsg
// {
//   Phantom ph3
//     {
//       NIC nicres1
//     }
// }
group primary2-strsg (
  SystemList = { primary2 = 0, alternate2 = 1 }
```

```
Parallel = 1
AutoStartList = { primary2, alternate2 }
)
Disk disk2 (
Partition @primary2 = "/dev/rdisk/c3t50060E8000C46C50d2s2"
  Partition @alternate2 = "/dev/rdisk/c1t50060E8000C46C50d2s2"
)
Phantom ph4 (
)
// resource dependency tree
//
// group primary2-strsg
// {
//   Phantom ph4
//     {
//       Disk disk2
//     }
// }
```

## Debug log levels for AlternatelIO agent

The AlternatelIO agent uses following debug log levels: `DBG_1`, and `DBG_3`

# Infrastructure and support agents

This chapter includes the following topics:

- [About the infrastructure and support agents](#)
- [NotifierMngr agent](#)
- [Proxy agent](#)
- [Phantom agent](#)
- [RemoteGroup agent](#)

## About the infrastructure and support agents

Use the infrastructure and support agents to monitor Veritas components and VCS objects.

## NotifierMngr agent

Starts, stops, and monitors a notifier process, making it highly available. The notifier process manages the reception of messages from VCS and the delivery of those messages to SNMP consoles and SMTP servers.

Refer to the *Admin Guide* for a description of types of events that generate notification. See the `notifier(1)` manual page to configure notification from the command line.

You cannot dynamically change the attributes of the NotifierMngr agent using the `hares -modify` command. Changes made using this command are only effective after restarting the notifier.

## Dependency

The NotifierMngr resource can depend on the NIC resource.

## Agent functions

Online	Starts the notifier process with its required arguments.
Offline	VCS sends a <code>SIGABORT</code> . If the process does not exit within one second, VCS sends a <code>SIGKILL</code> .
Monitor	Monitors the notifier process.
Clean	Sends <code>SIGKILL</code> .

## State definitions

ONLINE	Indicates that the Notifier process is running.
OFFLINE	Indicates that the Notifier process is not running.
UNKNOWN	Indicates that the user did not specify the required attribute for the resource.

## Attributes

**Table 6-1** Required attributes for Solaris

Required attribute	Description
SnmpConsoles	<p>Specifies the machine names of the SNMP managers and the severity level of the messages to be delivered. The severity levels of messages are Information, Warning, Error, and SevereError. Specifying a given severity level for messages generates delivery of all messages of equal or higher severity.</p> <p><b>Note:</b> SnmpConsoles is a required attribute if SntpServer is not specified; otherwise, SnmpConsoles is an optional attribute. Specify both SnmpConsoles and SntpServer if desired.</p> <p>Type and dimension: string-association</p> <p>Example:</p> <p>"172.29.10.89" = Error, "172.29.10.56" = Information</p>

**Table 6-1** Required attributes for Solaris (*continued*)

Required attribute	Description
SmtServer	<p>Specifies the machine name of the SMTP server.</p> <p><b>Note:</b> SmtServer is a required attribute if SnmpConsoles is not specified; otherwise, SmtServer is an optional attribute. You can specify both SmtServer and SnmpConsoles if desired.</p> <p>Type and dimension: string-scalar                      Example: "smtp.example.com"</p>

**Table 6-2** Optional attributes for Solaris

Optional attribute	Description
EngineListeningPort	<p>Change this attribute if the VCS engine is listening on a port other than its default port.</p> <p>Type and dimension: integer-scalar                      Default: 14141</p>
MessagesQueue	<p>Size of the VCS engine's message queue. Minimum value is 30.</p> <p>Type and dimension: integer-scalar                      Default: 30</p>
NotifierListeningPort	<p>Any valid, unused TCP/IP port number.</p> <p>Type and dimension: integer-scalar                      Default: 14144</p>
NotifierSourceIP	<p>If this attribute is populated, all the notifications sent from the notifier (SMTP and SNMP) will be sent from the interface having this IP address.</p> <p><b>Note:</b> Make sure that the SourceIP given in this attribute is present in the /etc/hosts file or is DNS-resolvable.</p> <p>Type and dimension: string-scalar                      Example: "10.209.77.111"</p>

**Table 6-2** Optional attributes for Solaris (*continued*)

Optional attribute	Description
SmtplibFromPath	<p>Set to a valid email address, if you want the notifier to use a custom email address in the FROM: field.</p> <p>Type and dimension: string-scalar</p> <p>Example: "usera@example.com"</p>
SmtplibRecipients	<p>Specifies the email address where SMTP sends information and the severity level of the messages. The severity levels of messages are Information, Warning, Error, and SevereError. Specifying a given severity level for messages indicates that all messages of equal or higher severity are received.</p> <p><b>Note:</b> SmtplibRecipients is a required attribute if you specify SmtplibServer.</p> <p>Type and dimension: string-association</p> <p>Example:</p> <pre>"james@example.com" = SevereError, "admin@example.com" = Warning</pre>
SmtplibReturnPath	<p>Set to a valid email address, if you want the notifier to use a custom email address in the Return-Path: &lt;&gt; field.</p> <p>If the mail server specified in SmtplibServer does not support SMTP VRFY command, then you need to set the SmtplibVrfyOff to 1 in order for the SmtplibReturnPath value to take effect.</p> <p>Type and dimension: string-scalar</p> <p>Example: "usera@example.com"</p>
SmtplibServerTimeout	<p>This attribute represents the time in seconds notifier waits for a response from the mail server for the SMTP commands it has sent to the mail server. This value can be increased if you notice that the mail server is taking a longer duration to reply back to the SMTP commands sent by notifier.</p> <p>Type and dimension: integer-scalar</p> <p>Default: 10</p>

**Table 6-2** Optional attributes for Solaris (*continued*)

Optional attribute	Description
SmtServerVrfyOff	Set this value to 1 if your mail server does not support SMTP VRFY command. If you set this value to 1, the notifier does not send a SMTP VRFY request to the mail server specified in SmtServer attribute while sending emails.  Type and dimension: boolean-scalar Default: 0
SnmpCommunity	Specifies the community ID for the SNMP manager.  Type and dimension: string-scalar Default: public
SnmpdTrapPort	Port on the SNMP console machine where SNMP traps are sent.  If you specify more than one SNMP console, all consoles use this value.  Type and dimension: integer-scalar Default: 162

## Resource type definition

```

type NotifierMngr (
  static int RestartLimit = 3
  static str ArgList[] = { EngineListeningPort, MessagesQueue,
  NotifierListeningPort, NotifierSourceIP, SnmpdTrapPort,
  SnmpCommunity, SnmpConsoles, SmtServer, SmtServerVrfyOff,
  SmtServerTimeout, SmtReturnPath, SmtFromPath,
  SmtRecipients }
  int EngineListeningPort = 14141
  int MessagesQueue = 30
  int NotifierListeningPort = 14144
  str NotifierSourceIP
  int SnmpdTrapPort = 162
  str SnmpCommunity = public
  str SnmpConsoles{}
  str SmtServer
  boolean SmtServerVrfyOff = 0
  int SmtServerTimeout = 10
  str SmtReturnPath
  str SmtFromPath

```



```
str Smtprcipients{  
}
```

## Sample configuration

In the following configuration, the NotifierMngr agent is configured to run with two resource groups: NicGrp and Grp1. NicGrp contains the NIC resource and a Phantom resource that enables VCS to determine the online and offline status of the group. See the Phantom agent for more information on verifying the status of groups that only contain OnOnly or Persistent resources such as the NIC resource. You must enable NicGrp to run as a parallel group on both systems.

Grp1 contains the NotifierMngr resource (ntfr) and a Proxy resource (nicproxy), configured for the NIC resource in the first group.

In this example, NotifierMngr has a dependency on the Proxy resource.

---

**Note:** Only one instance of the notifier process can run in a cluster. The process cannot run in a parallel group.

---

The NotifierMngr resource sets up notification for all events to the SNMP console `smpserv`. In this example, only messages of SevereError level are sent to the SMTP server (`smtp.example.com`), and the recipient (`vcsadmin@example.com`).

## Configuration

```
system north  
system south  
group NicGrp (  
  SystemList = { north = 0, south = 1 }  
  AutoStartList = { north }  
  Parallel = 1  
)  
Phantom my_phantom (  
)  
NIC NicGrp_e1000g0 (  
  Enabled = 1  
  Device = e1000g0  
  NetworkType = ether  
)  
group Grp1 (  
  SystemList = { north = 0, south = 1 }  
  AutoStartList = { north }
```

```
)  
Proxy nicproxy(  
  TargetResName = "NicGrp_en0"  
)  
NotifierMngr ntfr (  
  SnmpConsoles = { snmpserv = Information }  
  SntpServer = "smtp.example.com"  
  SntpRecipients = { "vcsadmin@example.com" = SevereError }  
)  
ntfr requires nicproxy  
// resource dependency tree  
//  
// group Grp1  
// {  
//   NotifierMngr ntfr  
//   {  
//     Proxy nicproxy  
//   }  
// }
```

## Debug log levels

The NotifierMngr agent uses the following debug log levels:

DBG\_1, DBG\_2, DBG\_3, DBG\_5

## Proxy agent

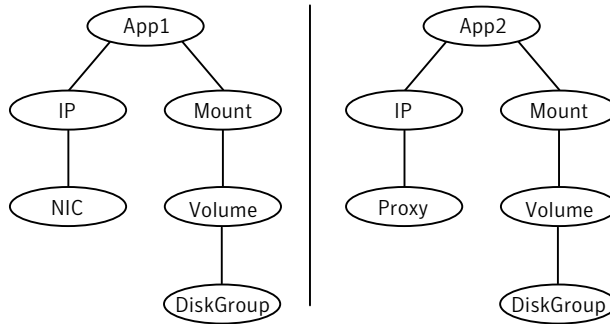
The Proxy agent mirrors the state of another resource on a local or remote system. It provides a means to specify and modify one resource and have its state reflected by its proxies. You can use the agent when you need to replicate the status of a resource.

A Proxy resource can only point to None or OnOnly type of resources, and can reside either in a failover or a parallel group. A target resource and its proxy cannot be in the same group.

## Dependencies

No dependencies exist for the Proxy resource.

**Figure 6-1** Sample service group that includes a Proxy resource



## Agent functions

Monitor                      Determines status based on the target resource status.

## Attributes

**Table 6-3** Required attribute

Required attribute	Description
TargetResName	Name of the target resource that the Proxy resource mirrors. The target resource must be in a different resource group than the Proxy resource. Type and dimension: string-scalar Example: "nic1"

**Table 6-4** Optional attribute

Optional attribute	Description
TargetSysName	Mirrors the status of the TargetResName attribute on systems that the TargetSysName variable specifies. If this attribute is not specified, the Proxy resource assumes the system is local. Type and dimension: string-scalar Example: "sysa"

## Resource type definition

```
type Proxy (  
    static str ArgList[] = { TargetResName, TargetSysName,  
        "TargetResName:Probed", "TargetResName:State" }  
    static int OfflineMonitorInterval = 60  
    static str Operations = None  
    str TargetResName  
    str TargetSysName  
)
```

## Sample configurations

### Configuration 1

```
Proxy proxy1 (  
    TargetResName = "nic1"  
)
```

### Configuration 2

The proxy resource mirrors the state of the resource nic2 on sysa.

```
Proxy proxy1(  
    TargetResName = "nic2"  
    TargetSysName = "sysa"  
)
```

### Configuration 3

The proxy resource mirrors the state of the resource mnic on the local system; the target resource is in grp1 and the proxy in grp2. A target resource and its proxy cannot be in the same group.

```
group grp1 (  
    SystemList = { sysa = 0, sysb = 1 }  
    AutoStartList = { sysa }  
)  
MultiNICA mnic (  
    Device@sysa = { le0 = "166.98.16.103", qfe3 = "166.98.16.103"  
    }  
    Device@sysb = { le0 = "166.98.16.104", qfe3 = "166.98.16.104"  
    }  
)
```

```
NetMask = "255.255.255.0"
ArpDelay = 5
Options = "failover"
)
IPMultiNIC ip1 (
Address = "166.98.16.78"
NetMask = "255.255.255.0"
MultiNICResName = mnic
Options = "failover"
)
ip1 requires mnic
group grp2 (
SystemList = { sysa = 0, sysb = 1 }
AutoStartList = { sysa }
)
IPMultiNIC ip2 (
Address = "166.98.16.79"
NetMask = "255.255.255.0"
MultiNICResName = mnic
Options = "mtu 1500"
)
Proxy proxy (
TargetResName = mnic
)
ip2 requires proxy
```

## Debug log levels

The Proxy agent uses the following debug log levels:

DBG\_1, DBG\_2

## Phantom agent

The agent enables VCS to determine the status of parallel service groups that do not include OnOff resources, which are resources that VCS can start and stop. Without the "dummy" resource provided by this agent, VCS cannot assess the status of groups that only contain None (Persistent) and OnOnly resources because the state of these resources is not considered in the process of determining whether a group is online. Refer to the *VCS Administrator's Guide* for information on categories of service groups and resources.

Do not use the Phantom resource in failover service groups.

Also, the Phantom resource should not be used in service groups that don't contain any resources.

---

**Note:** Do not attempt manual online or offline operations on the Phantom resource at the resource level. Do not use `hares` commands on the Phantom resource at the resource level. Unpredictable behavior results when you try a manual online or offline procedure or an `hares` command on a Phantom resource. You can perform commands on the service group that contains the Phantom resource.

---

## Dependencies

No dependencies exist for the Phantom resource.

**Figure 6-2** Sample service group that includes a Phantom resource



## Agent functions

Monitor	Determines status based on the status of the service group.
---------	---

## Resource type definition

```
type Phantom (
)
```

## Sample configurations

### Configuration 1

```
Phantom boo (
)
```

### Configuration 2

The following example shows a complete `main.cf`, in which the `FileNone` resource and the `Phantom` resource are in the same group.

```
include "types.cf"
cluster PhantomCluster
system sysa (
```

```
)
system sysb (
)
group phantomgroup (
SystemList = { sysa = 0, sysb = 1 }
AutoStartList = { sysa }
Parallel = 1
)
FileNone my_file_none (
PathName = "/tmp/file_none"
)
Phantom my_phantom (
)
// resource dependency tree
//
// group maingroup
// {
// Phantom my_Phantom
// FileNone my_file_none
// }
```

## RemoteGroup agent

The RemoteGroup agent establishes dependencies between applications that are configured on different VCS clusters. For example, you configure an Apache resource in a local cluster, and a MySQL resource in a remote cluster. In this example, the Apache resource depends on the MySQL resource. You can use the RemoteGroup agent to establish this dependency between these two resources.

With the RemoteGroup agent, you can monitor or manage a service group that exists in a remote cluster.

Some points about configuring the RemoteGroup resource follow:

- For each remote service group that you want to monitor or manage, you must configure a corresponding RemoteGroup resource in the local cluster.
- Multiple RemoteGroup resources in a local cluster can manage corresponding multiple remote service groups in different remote clusters.
- You can include the RemoteGroup resource in any kind of resource or service group dependency tree.
- A combination of the state of the local service group and the state of the remote service group determines the state of the RemoteGroup resource.

Symantec supports the RemoteGroup agent when:

- When it points to a global group  
The RemoteGroup agent must then map the state of the global group in the local cluster.
- When it is configured inside a local parallel service group  
The RemoteGroup resources on all cluster nodes monitor the same remote service group unless its attributes are localized.
- When it is configured inside a local failover service group

For more information on the functionality of this agent refer to the *Veritas Cluster Server Administrator's Guide*.

## Dependency

As a best practice, establish a RemoteGroup resource dependency on a NIC resource. Symantec recommends that the RemoteGroup resource not be by itself in a service group.

## Agent functions

Online	Brings the remote service group online. For more information: See <a href="#">Table 6-5</a> on page 257.
Offline	Takes the remote service group offline. For more information: See <a href="#">Table 6-5</a> on page 257.
Monitor	Monitors the state of the remote service group.  The true state of the remote service group is monitored only on the online node in the local cluster. For more information: See <a href="#">Table 6-5</a> on page 257.
Clean	If the RemoteGroup resource faults, the Clean function takes the remote service group offline. For more information: See <a href="#">Table 6-5</a> on page 257.

## State definitions

ONLINE	Indicates that the remote service group is in an ONLINE state.  If the ReturnIntOffline attribute is not set to RemotePartial, then the remote service group is either in an ONLINE or PARTIAL state.
--------	---



OFFLINE	<p>Indicates that the remote service group is in an OFFLINE or FAULTED state. The true state of the remote service group is monitored only on the online node in the local cluster.</p> <p>The RemoteGroup resource returns intentional offline if the attribute ReturnIntOffline is set to an appropriate value.</p>
FAULTED	<p>Indicates that the RemoteGroup resource has unexpectedly gone offline.</p>
UNKNOWN	<p>Indicates that a problem exists either with the configuration or the ability of the RemoteGroup resource to determine the state of the remote service group.</p>

## Attributes

**Table 6-5** Required attributes

Required attribute	Description
IpAddress	<p>The IP address or DNS name of a node in the remote cluster. The IP address can be either physical or virtual.</p> <p>When configuring a virtual IP address of a remote cluster, do not configure the IP resource as a part of the remote service group.</p> <p>Type and dimension: string-scalar</p> <p>Examples: "www.example.com" or "11.183.12.214"</p>
Port	<p>This is a required attribute when the remote cluster listens on a port other than the default value of 14141.</p> <p>See <a href="#">Table 6-6</a> on page 260.</p>
GroupName	<p>The name of the service group on the remote cluster that you want the RemoteGroup agent to monitor or manage.</p> <p>Type and dimension: string-scalar</p> <p>Example: "DBGrp"</p>

**Table 6-5** Required attributes (*continued*)

Required attribute	Description
VCSSysName	<p>You must set this attribute to either the VCS system name or the ANY value.</p> <ul style="list-style-type: none"> <li>■ ANY The RemoteGroup resource goes online if the remote service group is online on any node in the remote cluster.</li> <li>■ <i>VCSSysName</i> Use the name of a VCS system in a remote cluster where you want the remote service group to be online when the RemoteGroup resource goes online. Use this to establish a one-to-one mapping between the nodes of the local and remote clusters.</li> </ul> <p>Type and dimension: string-scalar            Example: "vcssys1" or "ANY"</p>
ControlMode	<p>Select only one of these values to determine the mode of operation of the RemoteGroup resource: MonitorOnly, OnlineOnly, or OnOff.</p> <ul style="list-style-type: none"> <li>■ OnOff The RemoteGroup resource brings the remote service group online or takes it offline. When you set the VCSSysName attribute to ANY, the SysList attribute of the remote service group determines the node where the remote service group onlines.</li> <li>■ MonitorOnly The RemoteGroup resource only monitors the state of the remote service group. The RemoteGroup resource cannot online or offline the remote service group. Make sure that you bring the remote service group online before you online the RemoteGroup resource.</li> <li>■ OnlineOnly The RemoteGroup resource only brings the remote service group online. The RemoteGroup resource cannot take the remote service group offline. When you set the VCSSysName attribute to ANY, the SysList attribute of the remote service group determines the node where the remote service group onlines.</li> </ul> <p>Type and dimension: string-scalar</p>

**Table 6-5** Required attributes (*continued*)

Required attribute	Description
Username	<p>This is the login user name for the remote cluster.</p> <p>When you set the ControlMode attribute to OnOff or OnlineOnly, the Username must have administrative privileges for the remote service group that you specify in the GroupName attribute.</p> <p>When you use the RemoteGroup Wizard to enter your username data, you need to enter your username and the domain name in separate fields. For a cluster that has the Symantec Product Authentication Service, you do not need to enter the domain name.</p> <p>For a secure remote cluster:</p> <ul style="list-style-type: none"> <li>■ Local Unix user  user@nodename—where the nodename is the name of the node that is specified in the IpAddress attribute. Do not set the DomainType attribute.</li> <li>■ NIS or NIS+ user  user@domainName—where domainName is the name of the NIS or NIS+ domain for the user. You must set the value of the DomainType attribute to either to nis or nisplus.</li> </ul> <p>Type and dimension: string-scalar</p> <p>Example:</p> <ul style="list-style-type: none"> <li>■ For a cluster without the Symantec Product Authentication Service: "johnsmith"</li> <li>■ For a secure remote cluster: "foobar@example.com"</li> </ul>
Password	<p>This is the password that corresponds to the user that you specify in the Username attribute. You must encrypt the password with the <code>vcscrypt -agent</code> command.</p> <p><b>Note:</b> Do not use the <code>vcscrypt</code> utility when entering passwords from a configuration wizard or the Cluster Manager (Java Console).</p> <p>Type and dimension: string-scalar</p>

**Table 6-6** Optional attributes

Optional attribute	Description
DomainType	<p>For a secure remote cluster only, enter the domain type information for the specified user.</p> <p>For users who have the domain type unixpwd, you do not have to set this attribute.</p> <p>Type: string-scalar</p> <p>Example: "nis", "nisplus"</p>
BrokerIp	<p>For a secure remote cluster only. If you need the RemoteGroup agent to communicate to a specific authentication broker, set the value of this attribute to the broker's IP address.</p> <p>Type: string-scalar</p> <p>Example: "128.11.295.51"</p>
Port	<p>The port where the remote engine listens for requests.</p> <p>This is an optional attribute, unless the remote cluster listens on a port other than the default value of 14141.</p> <p>Type and dimension: integer-scalar</p> <p>Default: 14141</p>
OfflineWaitTime	<p>The maximum expected time in seconds that the remote service group may take to offline. VCS calls the clean function for the RemoteGroup resource if the remote service group takes a longer time to offline than the time that you have specified for this attribute.</p> <p>Type and dimension: integer-scalar</p> <p>Default: 0</p>

**Table 6-6** Optional attributes (*continued*)

Optional attribute	Description
ReturnIntOffline	<p>Select one of the following values for RemoteGroup to return IntentionalOffline:</p> <ul style="list-style-type: none"> <li>■ RemotePartial—Indicates that the RemoteGroup resource returns an IntentionalOffline if the remote service group is in an ONLINE PARTIAL state.</li> <li>■ RemoteOffline—Indicates that the RemoteGroup resource returns an IntentionalOffline if the remote service group is in an OFFLINE state.</li> <li>■ RemoteFaulted—Indicates that the RemoteGroup resource returns an IntentionalOffline if the remote service group is OFFLINE FAULTED.</li> </ul> <p>You can use these values in combinations with each other.</p> <p>You must set the IntentionalOffline attribute of the RemoteGroup resource type to 1 for this attribute to work properly. For more information about this attribute, see the <i>Veritas Cluster Server Administrator's Guide</i>.</p> <p>Type and dimension: string-vector                      Default: ""</p>
OfflineMonitoringNode	<p>Defines the cluster node that performs the offline monitoring of the remote service group. This is an internal attribute. Do not modify.</p>

**Table 6-7** Type-level attributes

Type level attributes	Description
OnlineRetryLimit OnlineWaitLimit	<p>In case of remote service groups that take a longer time to Online, Symantec recommends that you modify the default OnlineWaitLimit and OnlineRetryLimit attributes.</p> <p>See the <i>Veritas Cluster Server Administrator's Guide</i> for more information about these attributes.</p>
ToleranceLimit MonitorInterval	<p>If you expect the RemoteGroup agent to tolerate sudden offlines of the remote service group, then modify the ToleranceLimit attribute.</p> <p>See the <i>Veritas Cluster Server Administrator's Guide</i> for more information about these attributes.</p>

**Table 6-7** Type-level attributes (*continued*)

Type level attributes	Description
ExternalStateChange	<p>If you want the local service group to go online or offline when the RemoteGroup resource goes online or offline outside VCS control, set the attribute ExternalStateChange appropriately.</p> <p>See the <i>Veritas Cluster Server Administrator's Guide</i> for more information about these attributes.</p>

## Resource type definition

```

type RemoteGroup (
  static int OnlineRetryLimit = 2
  static int ToleranceLimit = 1
  static boolean IntentionalOffline = 1
  static str ArgList[] = { IPAddress, Port, Username, Password,
  GroupName, VCSSysName, ControlMode, OfflineWaitTime,
  DomainType, BrokerIp, ReturnIntOffline }
  str IPAddress
  int Port = 14141
  str Username
  str Password
  str GroupName
  str VCSSysName
  str ControlMode
  int OfflineWaitTime
  str DomainType
  str BrokerIp
  str ReturnIntOffline[] = {}
  temp str OfflineMonitoringNode
)

```

## Debug log levels

The RemoteGroup agent uses the following debug log levels:

DBG\_1

# Testing agents

This chapter includes the following topics:

- [About the testing agents](#)
- [ElifNone agent](#)
- [FileNone agent](#)
- [FileOnOff agent](#)
- [FileOnOnly agent](#)

## About the testing agents

Use the testing agents to provide high availability for program support resources. These resources are useful for testing service groups.

## ElifNone agent

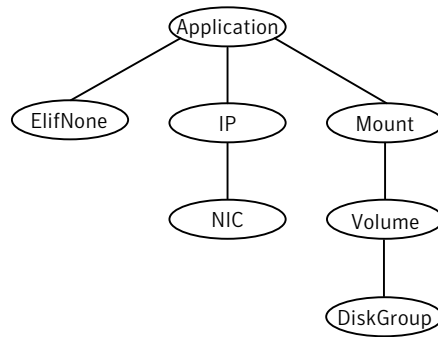
The ElifNone agent monitors a file. It checks for the file's absence.

You can use the ElifNone agent to test service group behavior. You can also use it as an impostor resource, where it takes the place of a resource for testing.

## Dependencies for ElifNone agent

No dependencies exist for the ElifNone resource.

**Figure 7-1** Sample service group that includes an ElifNone resource



## Agent function for ElifNone agent

Monitor	Checks for the specified file. If it exists, the resource faults. If it does not exist, the agent reports the resource as ONLINE.
---------	---

## State definitions for ElifNone agent

ONLINE	Indicates that the file specified in the PathName attribute does not exist.
FAULTED	Indicates that the file specified in the PathName attribute exists.
UNKNOWN	Indicates that the value of the PathName attribute does not contain a file name.

## Attributes for ElifNone agent

**Table 7-1** Required attribute

Required attribute	Description
PathName	Specifies the complete pathname. Starts with a slash (/) preceding the file name.  Type and dimension: string-scalar  Example: "/tmp/file01"



## Resource type definition for ElifNone agent

```
type ElifNone (  
    static str ArgList[] = { PathName }  
    static int OfflineMonitorInterval = 60  
    static str Operations = None  
    str PathName  
)
```

## Sample configuration for ElifNone agent

```
ElifNone tmp_file01 (  
    PathName = "/tmp/file01"  
)
```

## Debug log levels for ElifNone agent

The ElifNone agent uses the following debug log levels:

DBG\_4, DBG\_5

## FileNone agent

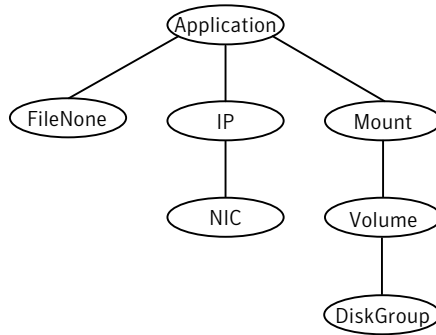
Monitors a file, checks for the file's existence.

You can use the FileNone agent to test service group behavior. You can also use it as an "impostor" resource, where it takes the place of a resource for testing.

## Dependencies for FileNone agent

No dependencies exist for the FileNone resource.

**Figure 7-2** Sample service group that includes a FileNone resource



## Agent functions for FileNone agent

**Monitor** Checks for the specified file. If it exists, the agent reports the resource as ONLINE. If it does not exist, the resource faults.

## State definitions for FileNone agent

**ONLINE** Indicates that the file specified in the PathName attribute exists.

**FAULTED** Indicates that the file specified in the PathName attribute does not exist.

**UNKNOWN** Indicates that the value of the PathName attribute does not contain a file name.

## Attribute for FileNone agent

**Table 7-2** Required attribute

Required attribute	Description
PathName	Specifies the complete pathname. Starts with a slash (/) preceding the file name. Type and dimension: string-scalar Example: "/tmp/file01"

## Resource type definition for FileNone agent

```
type FileNone (  
    static str ArgList[] = { PathName }  
    static int OfflineMonitorInterval = 60  
    static str Operations = None  
    str PathName  
)
```

## Sample configuration for FileNone agent

```
FileNone tmp_file01 (  
    PathName = "/tmp/file01"  
)
```

## Debug log levels for FileNone agent

The FileNone agent uses the following debug log levels:

DBG\_4, DBG\_5

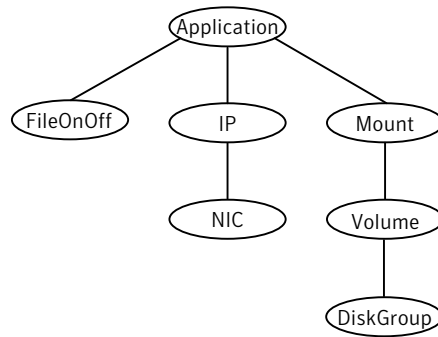
## FileOnOff agent

The FileOnOff agent creates, removes, and monitors a file.

You can use the FileNone agent to test service group behavior. You can also use it as an "impostor" resource, where it takes the place of a resource for testing.

## Dependencies for FileOnOff agent

No dependencies exist for the FileOnOff resource.

**Figure 7-3** Sample service group that includes a FileOnOff resource

## Agent functions for FileOnOff agent

Online	Creates an empty file with the specified name if the file does not already exist.
Offline	Removes the specified file.
Monitor	Checks for the specified file. If it exists, the agent reports as ONLINE. If it does not exist, the agent reports as OFFLINE.
Clean	Removes the specified file forcibly when necessary.

## State definitions for FileOnOff agent

ONLINE	Indicates that the file specified in the PathName attribute exists.
OFFLINE	Indicates that the file specified in the PathName attribute does not exist.
FAULTED	Indicates that the file specified in the PathName attribute has been removed out of VCS control.
UNKNOWN	Indicates that the value of the PathName attribute does not contain a file name.

## Attribute for FileOnOff agent

**Table 7-3** Required attribute

Required attribute	Description
PathName	Specifies the complete pathname. Starts with a slash (/) preceding the file name.  Type and dimension: string-scalar  Example: "/tmp/file01"

## Resource type definition for FileOnOff agent

```
type FileOnOff (  
    static str ArgList[] = { PathName }  
    str PathName  
)
```

## Sample configuration for FileOnOff agent

```
FileOnOff tmp_file01 (  
    PathName = "/tmp/file01"  
)
```

## Debug log levels for FileOnOff agent

The FileOnOff agent uses the following debug log levels:

DBG\_4, DBG\_5

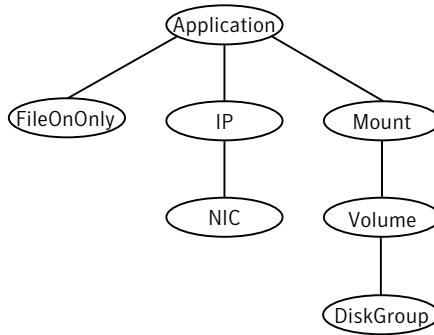
## FileOnOnly agent

The FileOnOnly agent creates and monitors a file.

You can use the FileNone agent to test service group behavior. You can also use it as an "impostor" resource, where it takes the place of a resource for testing.

## Dependencies for FileOnOnly agent

No dependencies exist for the FileOnOnly resource.

**Figure 7-4** Sample service group that includes a FileOnOnly resource

## Agent functions for FileOnOnly agent

Online	Creates an empty file with the specified name, unless one already exists.
Monitor	Checks for the specified file. If it exists, the agent reports as ONLINE. If it does not exist, the resource faults.

## State definitions for FileOnOnly agent

The state definitions for this agent follow:

ONLINE	Indicates that the file specified in the PathName attribute exists.
OFFLINE	Indicates that the file specified in the PathName attribute does not exist and VCS has not attempted to bring the resource online.
FAULTED	Indicates that the file specified in the PathName attribute has been removed out of VCS control.
UNKNOWN	Indicates that the value of the PathName attribute does not contain a file name.

## Attribute for FileOnOnly agent

**Table 7-4** Required attributes

Required attribute	Description
PathName	Specifies the complete pathname. Starts with a slash (/) preceding the file name.  Type and dimension: string-scalar  Example: "/tmp/file02"

## Resource type definition for FileOnOnly agent

```
type FileOnOnly (  
    static str ArgList[] = { PathName }  
    static str Operations = OnOnly  
    str PathName  
)
```

## Sample configuration for FileOnOnly agent

```
FileOnOnly tmp_file02 (  
    PathName = "/tmp/file02"  
)
```

## Debug log levels for FileOnOnly agent

The FileOnOnly agent uses the following debug log levels:

DBG\_4, DBG\_5

# Replication agents

This chapter includes the following topics:

- [About the replication agents](#)
- [RVG agent](#)
- [RVGPrimary agent](#)
- [RVGSnapshot](#)
- [RVGShared agent](#)
- [RVGLogowner agent](#)
- [RVGSharedPri agent](#)

## About the replication agents

Use the replication agents to provide high availability for VVR resources.

Refer to the *Veritas Storage Foundation and High Availability Solutions Replication Administrator's Guide* for information on configuring the Replication agents for high availability.

## RVG agent

Brings the RVG online, monitors read and write access to the RVG, and takes the RVG offline. This is a failover resource. The RVG agent enables replication between clusters. It manages the Primary VVR node in one cluster and the Secondary VVR node in another cluster. Each node can be failed over in its respective cluster. In this way, replication is made highly available.

The RVG agent manages the state of the RVG during local failovers. The RVGPrimary agent manages the role of the RVG during a wide area failover.



Using a VCS global cluster enables you to fail over the Primary role from a Primary VVR node to a Secondary VVR node.

The RVG agent includes the following key features:

- Removes potential single points of failure by enabling Primary and Secondary VVR nodes to be clustered.
- Enables you to bring a service group online to start VCS-managed applications that use VVR.
- Continues replication after a node in a cluster fails without losing updates.
- Ensures that VVR can be added to any VCS cluster by including the RVG resource type definitions.

An example configuration file for this agent that can be used as a guide when creating your configuration is located at:

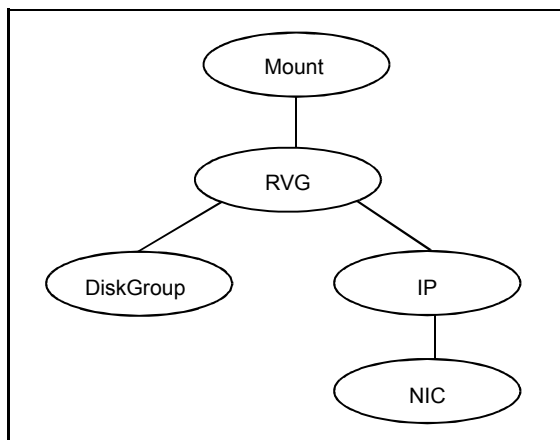
```
/etc/VRTSvcs/conf/sample_vvr/RVG
```

## Dependencies

The RVG resource represents the RVG (Replicated Volume Group) in the RDS (Replicated Data Set). The RVG resource is dependent on the DiskGroup resource. The RVG resource is also dependent on the IP resources that it uses for replication.

Refer to the *Veritas Cluster Server Administrator's Guide* for more information on dependencies.

**Figure 8-1** Sample service group for an RVG resource



## Agent functions

The RVG agent has the following agent functions:

Online	Verifies whether the DiskGroup agent has recovered the RVG. If not, recovers and starts the data volumes and the Storage Replicator Log (SRL), recovers the RVG, recovers all RLINKs in the RVG, and then starts the RVG.
Offline	Stops the RVG.
Monitor	Monitors the state of the RVG using the <code>vxprint</code> command.  The RVG resource monitors an RVG for local access only. It does not monitor replication.
Clean	Stops the RVG.
Info	The info entry point displays information about the replication status of a RDS.

## State definitions

The RVG agent has the following state definitions:

ONLINE	Indicates that the RVG is in <code>ENABLED/ACTIVE</code> state.
OFFLINE	Indicates that the RVG is in <code>DISABLED/CLEAN</code> state.
FAULTED	The RVG resource fails if the RVG is not in the <code>ENABLED/ACTIVE</code> state.

## Attributes

**Table 8-1** Required attributes

Required attributes	Description
RVG	The name of the RVG being monitored. Type and dimension: string-scalar Example: "hr_rvg"
DiskGroup	The disk group that this RVG is associated with. Type and dimension: string-scalar Example: "hrbg"

**Table 8-1** Required attributes (*continued*)

Required attributes	Description
StorageDG	The name of the bunker disk group. Type and dimension: string-scalar Example: "hr_bdg"
StorageRVG	The name of the bunker RVG. Type and dimension: string-scalar Example: "hr_brvg"
StorageHostIds	A space-separated list of the hostids of each node in the bunker cluster. Type and dimension: string-keylist Example: "bunker_host"

## Resource type definitions

The RVG agent resource type definition follows.

```
type RVG (  
    static int NumThreads = 1  
    static str ArgList[] = { RVG, DiskGroup }  
    str RVG  
    str DiskGroup  
    str StorageRVG  
    str StorageDG  
    str StorageHostIds  
)
```

## Sample configurations

```
RVG rvg (  
    RVG = ApplicationRVG  
    DiskGroup = vvrldg  
    StorageRVG = ApplicationRVG  
    StorageDG = vvrldg  
    StorageHostIds = "bunker_host"  
)
```

## RVGPrimary agent

The RVGPrimary agent enables migration and takeover of a VVR Replicated Volume Group (RVG) in a VCS environment. Bringing a resource of type RVGPrimary online causes the RVG on the local host to become a primary.

The agent is useful when hosts in both the primary and secondary side are clustered, in particular a VCS replicated data cluster or a VCS global cluster, to completely automate the availability of writable replicated disks to a VCS-managed application.

The RVGPrimary agent includes the following features:

- Removes the manual steps of migrating a VVR primary and secondary roles when failing over applications across a wide area.
- Minimizes the need for resynchronizing replicated volumes by attempting a migration before attempting a hard takeover.
- Waits for the two sides of a replicated data set to become completely synchronized before migrating roles.
- Supports an automatic fast failback resynchronization of a downed primary if it later returns after a takeover.
- Allows you to distinguish the Primary site after network failure or disaster
- Supports the ability to choose the Primary site after a site failure or network disruption is corrected.
- After a successful migration or takeover of a Secondary RVG, the RVGPrimary agent ensures to automatically start the replication from the new Primary to any additional Secondary(s) that exists in the RDS.
- Before a takeover, the RVGPrimary agent synchronizes the Secondary site with any bunker associated with the Primary site, when the Primary site is not available.

Refer to the *Veritas Storage Foundation and High Availability Solutions Replication Administrator's Guide* for information on configuring the Replication agents for high availability.

A sample configuration file for this agent that you can use as a guide to create the configuration is located at `/etc/VRTSvc/conf/sample_vvr/RVGPrimary`.

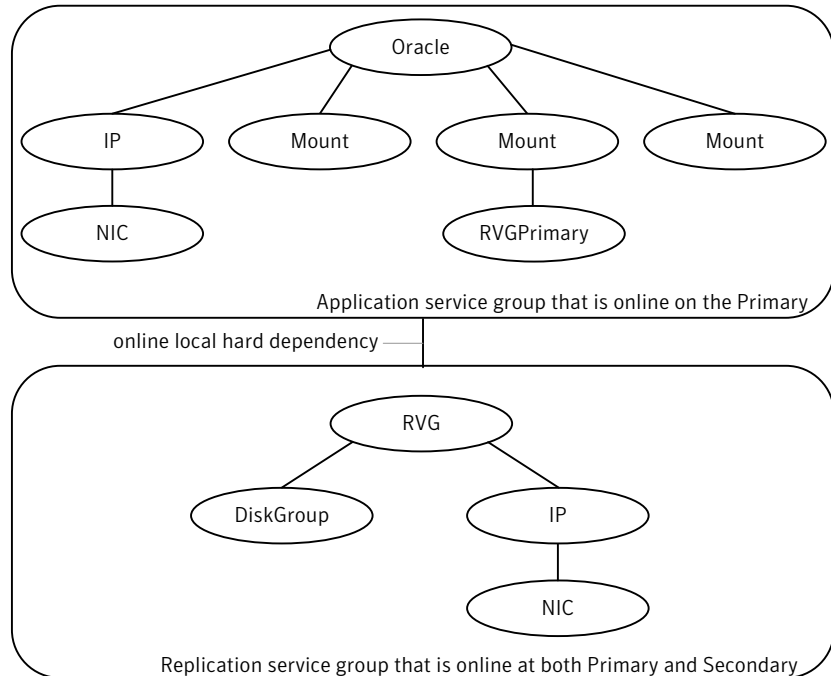
## Dependencies

You usually use the RVGPrimary agent in conjunction with the RVG agent in two groups with an online local hard group dependency. The parent group contains the resources that manage the actual application and file systems and as the

RVGPrimary resource. The child group contains the resources managing the storage infrastructure, which include the RVG and DiskGroup type resources.

Refer to the *Veritas Storage Foundation and High Availability Solutions Replication Administrator's Guide* for information about the setup of a VVR environment using the RVGPrimary agent.

**Figure 8-2** Sample service group for an RVGPrimary resource



## Agent functions

The RVGPrimary agent has the following agent functions:

- Online**      Determines the current role of the RVG. If the role is Secondary it attempts a migration. It waits for any outstanding writes from the original Primary. If the original Primary is down, it attempts a takeover. You can configure the RVGPrimary agent so that, before a takeover, the agent synchronizes the Secondary site with any bunker associated with the Primary site, when the Primary site is not available. If the RVG is a Primary, it performs no actions and goes online.
  
- Offline**      Performs no actions.

Monitor	Performs no actions. The RVG agents monitors the actual RVG.
Clean	Performs no actions.
fbsync	This is an action entry point.  It resynchronizes the original Primary with the new Primary that has taken over with fast-failback, after the original Primary had become unavailable. This needs to be executed when the original Primary becomes available and starts acting as a Secondary.
ElectPrimary	This is an action entry point.  It can be executed to retain the specified RVG as the Primary in a Primary-Primary configuration.  For more details, refer to the <i>Veritas Storage Foundation and High Availability Solutions Replication Administrator's Guide</i> .

## State definitions

The RVGPrimary agent has the following state definitions:

ONLINE	Indicates that the role of the RVG is Primary.
FAULTED	The RVG agents monitors the actual RVG. Accidental migration of a VVR Primary outside of VCS causes other resources to fault immediately, such as Mount. No special monitoring by this agent is necessary.

## Attributes

**Table 8-2** Required attributes

Required attributes	Description
RvgResourceName	The name of the RVG resource type that this agent promotes. The name RVG resource type which has been configured using the RVG agent.  Type and dimension: string-scalar
AutoTakeover	A flag to indicate whether the agent should perform a takeover on online if the original Primary is down.  AutoTakeover and AutoResync are mutually exclusive attributes.  When AutoTakeover=0, the primary-elect feature is not applicable; therefore, it is not supported.  Type and dimension: integer-scalar

**Table 8-2** Required attributes (*continued*)

Required attributes	Description
AutoResync	<p>Indicates whether the agent should attempt to automatically perform a fast-failback resynchronization of the original Primary after a takeover and after the original Primary returns.</p> <p>You can use the following values for this attribute:</p> <ul style="list-style-type: none"><li>■ 0—instructs the agent to not attempt to perform a fast-failback resynchronization of the original Primary after a takeover and after the original Primary returns.</li><li>■ 1—instructs the agent to attempt to automatically perform a fast-failback resynchronization of the original Primary after a takeover and after the original Primary returns.</li><li>■ 2—instructs the agent to use the primary-elect feature. The agent does not attempt to perform a fast-failback resynchronization of the original Primary after a takeover and after the original Primary returns. The RVGPrimary agent also creates space-optimized snapshots for all the data volumes in the RVG resource.</li></ul> <p>If you set the AutoResync attribute to 2 (to enable the primary-elect feature) the value of the BunkerSyncTimeOut attribute must be zero to disable the automated bunker replay feature. You cannot use the automated bunker replay feature and the primary-elect feature in the same environment.</p> <p>AutoTakeover and AutoResync are mutually exclusive attributes.</p> <p>When AutoTakeover=0, the primary-elect feature is not applicable; therefore, it is not supported.</p> <p>Type and dimension: integer-scalar</p>

**Table 8-2** Required attributes (*continued*)

Required attributes	Description
BunkerSyncTimeOut	<p>The value for the BunkerSyncTimeOut attribute determines if you want the bunker to perform a replay or not. You set the value in seconds for the time that you want to allot for the replay.</p> <p>Use one of the following values for the BunkerSyncTimeOut attribute:</p> <ul style="list-style-type: none"><li>■ If you do not use a value for this attribute (the default null value), the RVGPrimary agent considers it an infinite timeout value. The agent replays all the writes on the Bunker Replicator Log to the Secondary. Only after the agent sends all the writes, VCS performs the takeover on the Secondary.</li><li>■ If you set the value for this attribute to 0, you disable bunker replay for the agent. The RVGPrimary agent immediately performs a takeover on the Secondary. The agent does not send pending writes from the Bunker to the Secondary.</li><li>■ If you set the value to a number of seconds, then the RVGPrimary agent sends writes for that amount of time to the Secondary. After the agent meets the time limit, it performs the takeover on the Secondary. The bunker replay time in this case is equal to the value in seconds. You can set this value dynamically.</li></ul> <p>The RVGPrimary agent's OnlineTimeout and OnlineRetryLimit attribute values determine the available time for an RVGPrimary resource to complete its online operation.</p> <p>Use the following formula to get the Time Available for Online to Complete (TAOC):</p> $\text{TAOC} = (\text{OnlineTimeout} + (\text{OnlineRetryLimit} * \text{OnlineTimeout}))$



**Table 8-2** Required attributes (*continued*)

Required attributes	Description
BunkerSyncTimeOut (cont.)	<p>When you set the BunkerSyncTimeOut value in seconds, the value of TAOC for the RVGPrimary agent should be greater than the desired BunkerSyncTimeOut value. Using a TAOC value that is greater than BunkerSyncTimeOut value ensures that the bunker replay and the RVG takeover can complete in the allotted time for that particular online operation. If the TAOC is smaller than BunkerSyncTimeOut value and the bunker replay does not complete within the allotted time for the online process, the resource faults. If the resource faults, clear the fault. Try the online operation again if the resource has not failed over to other cluster node in the configuration.</p> <p>If you increase the value of the BunkerSyncTimeOut attribute, you need to increase the value of the OnlineTimeout or OnlineRetryLimit attribute so that TAOC remain greater than changed value. This is to ensure to have bunker replay completed within allotted time for online.</p> <p>If the value of the AutoResync attribute is 2, you must set the value of the BunkerSyncTimeOut attribute to 0 (to disable automated bunker replay).</p> <p>Type and dimension: string-scalar</p> <p>Default value: ""</p>

**Table 8-3** Internal attribute

Internal attribute	Description
BunkerSyncElapsedTime	<p>For internal use only, do not modify. This value in seconds signifies the amount of time that a Secondary RVG has waited for synchronization from the bunker host to complete.</p> <p>Type and dimension: integer-scalar</p>

## Resource type definitions

The RVGPrimary resource type definition follows.

```

type RVGPrimary (
    static keylist SupportedActions = { fbsync, electprimary }
    static int NumThreads = 1
    static int OnlineRetryLimit = 1
    static str ArgList[] = { RvgResourceName, "RvgResourceName:RVG",

```

```

    "RvgResourceName:DiskGroup", AutoTakeover, AutoResync,
    BunkerSyncTimeOut, BunkerSyncElapsedTime }
    str RvgResourceName
    int AutoTakeover = 1
    int AutoResync = 0
    str BunkerSyncTimeOut
    int BunkerSyncElapsedTime = 0
)

```

## Sample configurations

```

RVGPrimary rvg-pri (
    RvgResourceName = rvgRes
)

```

## RVGSnapshot

For a fire drill, creates and destroys a transactionally consistent space-optimized snapshot of all volumes in a VVR secondary replicated data set. The RVGSnapshot agent takes space-optimized snapshots on a secondary RVG. These snapshots can be mounted and written to without affecting the actual replicated data, which means that the space-optimized snapshot can be an effective tool for scheduling a “fire drill” to confirm that a wide-area failover is possible. By combining this agent with the VCS Mount agent, the CFMount agent, and VCS agents that manage the application being replicated, you can create a special fire drill service group. You can bring this service group online and take it offline at regularly scheduled intervals to verify that the disaster recovery environment is robust.

In addition to the agent itself, a text-based wizard `/opt/VRTSvcs/bin/fdsetup` that prepares the VVR and VCS infrastructure for a fire drill and a script `/opt/VRTSvcs/bin/fdsched` that runs the fire drill and consolidates the results are also included.

Complete details are in the *Veritas Cluster Server Administrator's Guide*.

The RVGSnapshot agent includes the following key features:

- Automates the process of creating a space-optimized snapshot on a VVR secondary that can be mounted to simulate a wide-area failover without affecting the production application.
- Includes a wizard to effectively set up and schedule fire drills that are completely managed by VCS.

---

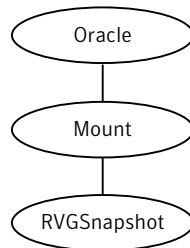
**Note:** The RVGSnapshot agent does not support Volume Sets.

---

## Dependencies

The RVGSnapshot agent depends on these resources.

**Figure 8-3** Sample service group for an RVGSnapshot resource



## Agent functions

The RVGSnapshot agent has the following agent functions:

Online	Creates a transactionally consistent snapshot of all volumes in the RVG.
Offline	Destroys the snapshot.
Monitor	No operation; failure of the snapshot will be indicated by the failure of the Mount resource of any file systems mounted on it.
Clean	Cleans up any failed snapshot creation or deletion.

## State definitions

The RVGSnapshot agent has the following state definitions:

ONLINE	Indicates that a snapshot was created.
OFFLINE	Indicates that a snapshot was destroyed.
FAULTED	The RVGSnapshot resource faults on timeout if a snapshot creation did not succeed during an online.

## Attributes

**Table 8-4** Required attributes

Required attributes	Description
RvgResourceName	The name of the VCS RVG-type resource that manages the RVG that will be snapshot by this agent. Type and dimension: string-scalar
CacheObj	Name of the cache object that is required for a space-optimized snapshot; the fdsetup wizard will create one if it does not exist Type and dimension: string-scalar
Prefix	Token put before the name of the actual volume when creating the snapshotted volumes. Type and dimension: string-scalar

**Table 8-5** Optional attributes

Optional attributes	Description
DestroyOnOffline	A flag to indicate whether to destroy the snapshot upon taking the resources offline. For a fire drill, the snapshot should be deleted to reduce any performance impact of leaving the snapshot for a long period of time; however, if there is interest in keeping the data, then this value should be set to 0. The default is 1 (true). Type and dimension: integer-scalar Default: 1
FDFile	The fire drill schedule updates this attribute with the system name and the path to a file containing the output of the last complete fire drill for the group containing an RVGSnapshot resource. Type and dimension: string-scalar

## Resource type definitions

The resource type definition for the RVGSnapshot agent follows.

```
type RVGSnapshot (
  static keylist RegList = { Prefix }
  static int NumThreads = 1
  static str ArgList[] = { RvgResourceName, CacheObj, Prefix,
```

```
DestroyOnOffline }  
str RvgResourceName  
str CacheObj  
str Prefix  
boolean DestroyOnOffline = 1  
temp str FDFile  
temp str VCSResLock  
)
```

## Sample configurations

```
RVGSnapshot rvg-sos (  
    RvgResourceName = ApplicationRVG  
    CacheObj = cacheobj  
    Prefix = snap  
)
```

## RVGShared agent

Monitors the RVG in a shared environment. This is a parallel resource. The RVGShared agent enables you to configure parallel applications to use an RVG in a cluster. The RVGShared agent monitors the RVG in a shared disk group environment. The RVGShared agent must be configured as a parallel group in VCS. Typically, the RVGShared resource is online or offline at the same time on all the nodes in the VCS cluster. An example configuration file for this agent that can be used as a guide when creating your configuration is located at `/etc/VRTSvcs/conf/sample_vvr/RVGLogowner`.

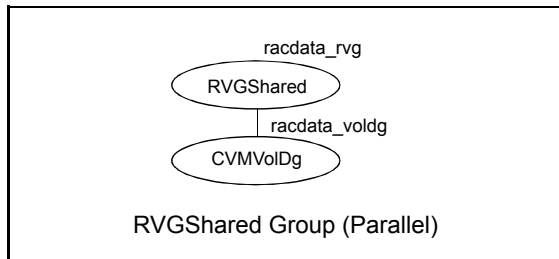
## Dependencies

The RVGShared resource represents the RVG of the RDS. The RVGShared resource is dependent on the CVMVolDg resource.

The RVGShared resource must be configured in a parallel group.

Refer to the *Veritas Storage Foundation and High Availability Solutions Replication Administrator's Guide* for information on configuring parallel applications for highly availability.

Refer to the *Veritas Cluster Server Administrator's Guide* for more information on dependencies.

**Figure 8-4** Sample service group for an RVGShared resource

---

**Note:** Do not add any volumes that are part of the RVG in the CVMVolume attribute of the CVMVolDg resource. The volumes in the RVG are managed by the RVGShared resource.

---

## Agent functions

The RVGShared agent has the following agent functions:

Online	Verifies whether the RVG is started. If the RVG is not started, recovers and starts the RVG.
Offline	No action.
Monitor	Displays the state as <code>ONLINE</code> if the RVG is started. Displays the state as <code>OFFLINE</code> if the RVG is not started.
Clean	No action.
Info	The info entry point displays information about the replication status of a RDS.

## State definitions

The RVGShared agent has the following state definitions:

ONLINE	Indicates that the RVG is in the <code>ENABLED/ACTIVE</code> state.
OFFLINE	Indicates that the RVG is not in the <code>ENABLED/ACTIVE</code> state or that the administrator has invoked the offline entry point.

## Attributes

**Table 8-6** Required attributes

Required attributes	Description
RVG	The name of the RVG being monitored. Type and dimension: string-scalar
DiskGroup	The shared-disk group with which this RVG is associated. Type and dimension: string-scalar

## Resource type definitions

The RVGShared resource type definition follows.

```
type RVGShared (
    static int NumThreads = 1
    static str ArgList[] = { RVG, DiskGroup }
    str RVG
    str DiskGroup
)
```

## Sample configurations

```
RVGShared racdata_rvg (
    RVG = rac1_rvg
    DiskGroup = oradatadg
)
```

## RVGLogowner agent

Assigns and unassigns a node as the logowner in the CVM cluster; this is a failover resource. The RVGLogowner agent assigns or unassigns a node as a logowner in the cluster. To replicate data, VVR requires network connectivity between the Primary and the Secondary. In a shared disk group environment, only one node, that is, the logowner, can replicate data to the Secondary.

For replication to be highly available, the logowner must be highly available. To make the logowner highly available, the RVGLogowner resource must be configured as a resource in a failover group. Also, a virtual IP must be set up on the logowner to enable replication and failover of the logowner from one node to another in a cluster. The virtual IP must be configured as an IP resource.

For more information about the logowner, see the *Veritas Storage Foundation and High Availability Solutions Replication Administrator's Guide*. An example configuration file for this agent that can be used as a guide when creating your configuration, is located at `/etc/VRTSvcs/conf/sample_vvr/RVGLogowner`.

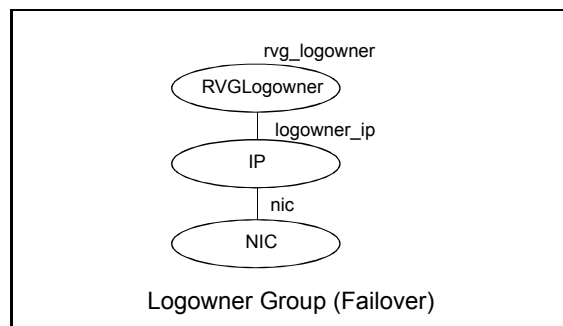
## Dependencies

The RVGLogowner resource represents the logowner for RVG in the cluster. The RVGLogowner resource is dependent on the IP resource that it uses for replication.

The RVGLogowner resource must be configured in a failover group. The RVGLogowner group is used in conjunction with the RVGSharedPri and RVGShared agents in separate groups, with the appropriate service group dependencies.

For more information on dependencies, refer to the *Veritas Cluster Server Administrator's Guide*

**Figure 8-5** Sample service group for an RVGLogowner resource



## Agent functions

The RVGLogowner agent has the following agent functions:

- |         |  |
|---------|--|
| Online  | Assigns the logowner on the node.  |
| Offline | Unassigns the logowner on the node.  |
| Monitor | Returns <code>ONLINE</code> if the node is the logowner and the RVG is in <code>ENABLED/ACTIVE</code> state. Returns <code>OFFLINE</code> if the node is the logowner and the state is not <code>ENABLED/ACTIVE</code> , or if the node is not the logowner (regardless of the state). The RVG for which the logowner is monitored must be configured as the <code>RVGShared</code> resource type. |
| Clean   | Unassigns the logowner on the node.  |



## State definitions

The RVGLogowner agent has the following state definitions:

- ONLINE      Indicates that the node is the logowner for the RVG in the cluster.
- OFFLINE     Indicates that the node is not the logowner for the RVG in the cluster.

## Attributes

**Table 8-7**      Required attributes

Required attributes	Description
RVG	The name of the RVG being monitored. Type and dimension: string-scalar Example: "hr_rvg"
DiskGroup	The disk group with which this RVG is associated. Type and dimension: string-scalar Example: "hrbg"

**Table 8-8**      Internal attributes

Bunker attributes	Description
StorageDG	For internal use only, do not modify. The name of the bunker disk group. Type and dimension: string-scalar Example: "hr_bdg"
StorageRVG	For internal use only, do not modify. The name of the bunker RVG. Type and dimension: string-scalar Example: "hr_brvg"
StorageHostIds	For internal use only, do not modify. A space-separated list of the hostids of each node in the bunker cluster. Type and dimension: string-keylist Example: "bunker_host"

## Resource type definitions

The RVGLogowner resource type definition follows.

```
type RVGLogowner (
    static int NumThreads = 1
    static str ArgList[] = { RVG, DiskGroup }
    static int OnlineRetryLimit = 5
    str RVG
    str DiskGroup
    str StorageRVG
    str StorageDG
    str StorageHostIds
)
```

## RVGLogowner agent notes

The RVGLogowner agent has the following notes:

### **CVM master node needs to assume the logowner role for VCS managed VVR resources**

If you use VCS to manage RVGLogowner resources in an SFCFSHA environment or an SF Oracle RAC environment, Symantec recommends that you perform the following procedures. These procedures ensure that the CVM master node always assumes the logowner role. Not performing these procedures can result in unexpected issues that are due to a CVM slave node that assumes the logowner role.

For a service group that contains an RVGLogowner resource, change the value of its `TriggersEnabled` attribute to `PREONLINE` to enable it.

#### **To enable the `TriggersEnabled` attribute from the command line on a service group that has an RVGLogowner resource**

- ◆ On any node in the cluster, perform the following command:

```
# hagrps -modify RVGLogowner_resource_sg TriggersEnabled PREONLINE
```

Where *RVGLogowner\_resource\_sg* is the service group that contains the RVGLogowner resource.

To enable the `preonline_vvr` trigger, do one of the following:

- If preonline trigger script is not already present, copy the preonline trigger script from the sample triggers directory into the triggers directory:

```
# cp /opt/VRTSvcs/bin/sample_triggers/VRTSvcs/preonline_vvr  
/opt/VRTSvcs/bin/triggers/preonline
```

Change the file permissions to make it executable.

- If preonline trigger script is already present, create a directory such as /preonline and move the existing preonline trigger as T0preonline to that directory. Copy the preonline\_vvr trigger as T1preonline to the same directory.
- If you already use multiple triggers, copy the preonline\_vvr trigger as TNpreonline, where TN is the next higher TNumber.

## Sample configurations

```
RVGLogowner vvr_rvglogowner (  
    RVG = app_rvg  
    DiskGroup = vvrldg  
)
```

## RVGSharedPri agent

Attempts to migrate or takeover a Secondary to a Primary when a parallel service group fails over. The RVGSharedPri agent enables migration and takeover of a VVR replicated data set in parallel groups in a VCS environment. Bringing a resource of type RVGSharedPri online causes the RVG on the local host to become a primary if it is not already. The agent is useful when hosts in both the primary and secondary side are clustered using a VCS global cluster, to completely automate the availability of writable replicated disks to an application managed by VCS.

You cannot use the primary-elect feature with this agent. For a detailed description of the primary-elect feature, see *Veritas Storage Foundation and High Availability Solutions Replication Administrator's Guide*.

The RVGSharedPri agent includes the following key features:

- Removes manual steps of migrating a VVR primary and secondary roles when failing over applications across a wide area.
- Minimizes the need for resynchronizing replicated volumes by attempting a migration before attempting a hard takeover.
- Waits for the two sides of a replicated data set to become completely synchronized before migrating roles.
- Supports an automatic fast failback resynchronization of a downed primary if it later returns after a takeover.

Sample configuration files are located in the `/etc/VRTSvcs/conf/sample_rac/` directory and include CVR in the filename. These sample files are installed as part of the VRTSdbac package, and can be used as a guide when creating your configuration.

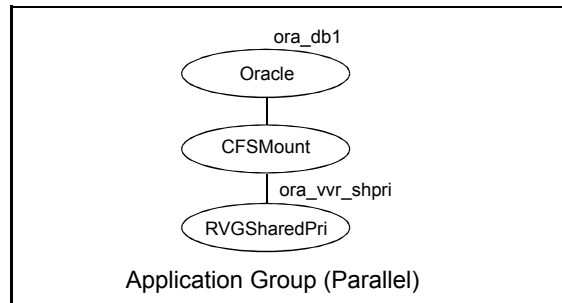
## Dependencies

The RVGSharedPri agent is used in conjunction with the RVGShared and RVGLogowner agents in separate groups, with the appropriate service group dependencies.

Refer to the *Veritas Storage Foundation and High Availability Solutions Replication Administrator's Guide* for information on configuring parallel applications for highly availability.

The RVGSharedPri agent must be configured in a parallel service group. The application service group contains the resources managing the actual application and file systems as well as the RVGSharedPri agent.

**Figure 8-6** Sample service group for an RVGSharedPri resource



## Agent functions

The RVGSharedPri agent has the following agent functions:

Online	Determines the current role of the RVG; if Secondary, attempt a migrate, waiting for any outstanding writes from the original Primary; if the original Primary is down attempt a takeover; if the RVG is a Primary, perform no actions and go online
Offline	Performs no actions.
Monitor	Performs no actions; monitoring of the actual RVG is done by the RVGShared agent.
Clean	Performs no actions.

fbsync	<p>This is an action entry point.</p> <p>It resynchronizes the original Primary with the new Primary that has taken over with fast-failback, after the original Primary had become unavailable.</p> <p>This needs to be executed when the original Primary becomes available and starts acting as a Secondary.</p>
resync	<p>This is an action entry point.</p> <p>It resynchronizes the Secondaries with the Primary using DCM.</p>

## State definitions

The RVGSharedPri agent has the following state definitions:

FAULTED	Monitoring of the actual RVG is done by the RVGShared agent; accidental migration of a VVR Primary outside of VCS would cause other resources to fault immediately, such as Mount, so no special monitoring by this agent is necessary.
---------	---

## Attributes

**Table 8-9** Required attributes

Required attributes	Description
RvgResourceName	<p>The name of the RVGShared resource type that this agent will promote, that is, the name RVG resource type which has been configured using the RVGShared agent.</p> <p>Type and dimension: string-scalar</p>
AutoTakeover	<p>A flag to indicate whether the agent should perform a takeover on online if the original Primary is down.</p> <p>Type and dimension: integer-scalar</p> <p>Default: 1</p>
AutoResync	<p>A flag to indicate whether the agent should attempt to automatically perform a fast-failback resynchronization of the original Primary after a takeover and after the original Primary returns.</p> <p>Type and dimension: integer-scalar</p> <p>Default: 0</p>
VCSResLock	<p>This attribute is reserved for internal use by VCS.</p> <p>Type and dimension: string-scalar</p>

## Resource type definitions

The RVGSharedPri resource type definition follows.

```
type RVGSharedPri (  
    static keylist SupportedActions = { fbsync, resync }  
    static int NumThreads = 1  
    static int OnlineRetryLimit = 1  
    static str ArgList[] = { RvgResourceName, "RvgResourceName:RVG",  
        "RvgResourceName:DiskGroup", AutoTakeover, AutoResync }  
    str RvgResourceName  
    int AutoTakeover = 1  
    int AutoResync = 0  
    temp str VCSResLock  
)
```

## Sample configurations

```
RVGSharedPri ora_vvr_shpri (  
    RvgResourceName = racdata_rvg  
    OnlineRetryLimit = 0  
)
```

# Index

## Symbols

802.1Q trunking 81

## A

about

Network agents 80

Samba agents 166

agent

modifying 19

agent functions

AlternateIO agent 238

Apache HTTP server agent 181

Application agent 193

CoordPoint agent 205

Disk agent 51

DiskGroup agent 25

DiskGroupSnap agent 37

DNS agent 132

ElifNone agent 264

FileNone agent 266

FileOnOff agent 268

FileOnOnly agent 270

IP agent 83

IPMultiNIC agent 95

IPMultiNICB agent 109

LDom agent 227

Mount agent 59

MultiNICA agent 100

MultiNICB agent 116

NetBIOS agent 175

NFS agent 149

Solaris 149

NFSRestart agent 155

Solaris 155

NIC agent 89

NotifierMngr agent 245

Phantom agent 254

Process agent 209

ProcessOnOnly agent 213

Project agent 235

Proxy agent 251

agent functions *(continued)*

RemoteGroup agent 256

SambaServer agent 168

SambaShare agent 172

Share agent 163

Solaris 163

Volume agent 53

VolumeSet agent 55

Zone agent 218

Zpool agent 73

agents. *See* RVG agent

AlternateIO 237

Apache HTTP server 179

Application 192

CoordPoint 203

Disk 51

DiskGroup 24

DiskGroupSnap 36

DNS 131

ElifNone 263

FileNone 265

FileOnOff 267

FileOnOnly 269

IP 82

IPMultiNIC 94

IPMultiNICB 108

LDom 226

Mount 57

MultiNICA 99

NetBIOS 174

NFS 148

NFSRestart 154

NIC 88

NotifierMngr 244

Phantom 253

Process 208

ProcessOnOnly 212

Project 234

Proxy 250

RemoteGroup 255

RVGLogowner. *See* RVGLogowner agent

RVGPrimary. *See* RVGPrimary agent

**agents** (*continued*)

- RVGShared. *See* RVGShared agent
- RVGSharedPri. *See* RVGSharedPri agent
- RVGSnapshot. *See* RVGSnapshot agent
- SambaServer 168
- SambaShare 171
- Share 162
- Volume 52
- Zone 215
- Zpool 72

**AlternateIO agent**

- agent functions 238
- description 237

**Apache HTTP server agent**

- agent functions 181
- attributes 182
- description 179
- detecting application failure 188
- sample configuration 190
- state definitions 181

**Application agent**

- agent functions 193
- attributes 196
- description 192
- high availability fire drill 193
- resource type definition 199
- sample configurations 202
- Solaris attributes 196
- state definitions 195

**association dimension 19****attribute data types 19****attributes**

- Application agent 196
  - Solaris 196
- Base and Mpathd modes 118
- Base mode 119
- CoordPoint agent 206
- Disk agent 52
- DiskGroup agent 27
  - Solaris 27
- DiskGroupSnap agent 38
- DNS agent 134
- ElifNone agent 264
- FileNone agent 266
- FileOnOff agent 269
- FileOnOnly agent 271
- IP agent 84
  - Solaris 84

**attributes** (*continued*)

- IPMultiNIC agent 96
  - Solaris 96
- IPMultiNICB agent 110
  - Solaris 110
- LDom agent 228
  - Solaris 228
- modifying 19
- Mount agent 61
  - Solaris 61
- Multi-pathing mode 123
- MultiNICA agent 100
- MultiNICB agent 116
- NFS agent 150
  - Solaris 150
- NFSRestart agent 157
  - Solaris 157
- NIC agent 90
  - Solaris 90
- NotifierMngr agent 245
  - Solaris 245
- ProcessOnOnly agent 214
  - Solaris 214
- Proxy agent 251
- RemoteGroup agent 257
- SambaServer agent 169
- Share agent 164
  - Solaris 164
- Volume agent 54
- VolumeSet agent 56
- Zpool agent 75
  - Solaris 75

**AutoResync attribute**

- RVGPrimary agent 293

**B**

- Base mode 125
- boolean data types 19

**C**

- Checklist to ensure the proper operation of
  - MultiNICB 107
- Cluster Manager (Java Console)
  - modifying attributes 19
- CNAME record 143
- configuration files
  - main.cf 254
  - modifying 19



configuration files *(continued)*  
 types.cf 19  
 CoordPoint agent  
 agent functions 205  
 attributes 206  
 description 203  
 resource type definition 206  
 sample configurations 207  
 state definitions 205

## D

data type  
 boolean 19  
 string 19  
 data types  
 integer 19  
 Dependencies  
 AlternateIO agent 237  
 dependency graphs  
 RVGLogowner agent 288  
 RVGPrimary agent 276  
 RVGShared agent 285  
 RVGSharedPri agent 292  
 description  
 resources 19  
 dimensions  
 keylist 19  
 scalar 19  
 vector 19  
 Disk agent  
 agent functions 51  
 attributes 52  
 description 51  
 resource type definition 52  
 state definitions 51  
 DiskGroup agent  
 agent functions 25  
 attributes 27  
 description 24  
 high availability fire drill 33  
 resource type definition 32  
 sample configurations 35  
 Solaris attributes 27  
 state definitions 27  
 DiskGroupSnap agent  
 agent functions 37  
 attributes 38  
 description 36  
 resource type definition 43

DiskGroupSnap agent *(continued)*  
 sample configurations 43  
 state definitions 38  
 DNS agent 133  
 agent functions 132  
 attributes 134  
 description 131  
 resource type definition 140  
 sample web server configuration 143

## E

ElifNone agent  
 agent functions 264  
 attributes 264  
 description 263  
 resource type definition 265  
 sample configuration 265  
 state definitions 264

## F

failover group  
 RVGLogowner agent 287  
 fast failback  
 AutoResync attribute of RVGPrimary 293  
 fast failback resynchronization  
 RVGPrimary 276  
 RVGSharedPri 291  
 Fiber Channel adapter 35  
 FileNone agent  
 agent functions 266  
 attribute 266  
 description 265  
 resource type definition 267  
 sample configurations 267  
 state definitions 266  
 FileOnOff agent  
 agent functions 268  
 attribute 269  
 description 267  
 state definitions 268  
 FileOnOnly agent  
 agent functions 270  
 attribute 271  
 description 269  
 resource type definition 271  
 sample configuration 271  
 state definitions 270

fire drill  
 RVGSnapshot agent 282

## H

high availability fire drill 33, 68, 82, 88, 143, 158, 193, 209

## I

integer data types 19  
 Interface configuration 128  
 IP agent  
   agent functions 83  
   attributes 84  
   description 82  
   high availability fire drill 82  
   resource type definitions 86  
   sample configurations 87  
   Solaris attributes 84  
   state definitions 83  
 IP Multi-pathing mode  
   Solaris 11 127  
 IPMultiNIC agent  
   agent functions 95  
   attributes 96  
   description 94  
   resource type definitions 97  
   sample configuration 98  
   Solaris attributes 96  
   state definitions 95  
 IPMultiNICB agent 114  
   agent functions 109  
   description 108  
   manually migrating IP address 113  
   requirements 109  
   resource type definition 113  
   Solaris attributes 110  
   state definitions 110

## K

keylist dimension 19

## L

LDom agent  
   agent functions 227  
   attributes 228  
   description 226  
   resource type definition 232  
   sample configurations 233

LDom agent (*continued*)  
   Solaris attributes 228  
   state definitions 227  
 logowner  
   virtual IP requirement 287

## M

main.cf 19, 254  
 main.xml 19  
 migrating  
   RVGPrimary 276  
   RVGSharedPri 291  
 modifying  
   configuration files 19  
 modifying agents 19  
 monitor scenarios  
   DNS agent 143  
 Mount agent  
   agent functions 59, 61  
   attributes 61  
   description 57  
   high availability fire drill 68, 143, 158  
   notes 67  
   resource type definition 67  
   sample configurations 72  
   Solaris attributes 61  
 Multi-pathing mode 126  
 MultiNICA agent 104  
   agent functions 100  
   attributes 100  
   description 99  
   resource type attributes 103  
   RouteOptions 104  
   sample configurations 105  
   state definitions 100  
 MultiNICB agent 116  
   administrative IP addresses 128  
   agent functions 116  
   attributes 116  
   base and multipath  
     Solaris 125  
   Base mode  
     Solaris 115  
   Multipathing mode  
     Solaris 115  
   resource type definition 124  
   sample configurations 128  
   state definitions 116  
   test IP addresses 128

**N**

- NetBIOS agent
  - agent functions 175
  - description 174
  - resource type definition 176
  - sample configurations 177
  - state definitions 175
- NFS agent
  - agent functions 149
    - Solaris 149
  - attributes 150
    - Solaris 150
  - description 148
  - resource type definition 151
  - sample configurations 153
  - state definitions 150
- NFSRestart agent
  - agent functions 155
    - Solaris 155
  - attributes 157
    - Solaris 157
  - description 154
  - resource type definition 158
  - sample configuration 161
  - state definitions 156
- NIC agent
  - agent functions 89
  - attributes 90
    - Solaris 90
  - description 88
  - high availability fire drill 88
  - resource type definitions 91
  - sample configurations 92
  - state definitions 89
- noautoimport flag 34
- NotifierMngr agent
  - agent functions 245
  - attributes 245
  - description 244
  - resource type definition 248
  - sample configurations 249
  - Solaris attributes 245
  - state definitions 245

**O**

- online query 143

**P**

- parallel group
  - RVGShared agent 285
- Phantom agent
  - agent functions 254
  - description 253
  - resource type definition 254
  - sample configurations 254
- prerequisites
  - Samba agents 166
- Process agent 210
  - agent functions 209
  - attributes 210
    - Solaris 210
  - description 208
  - high availability fire drill 209
  - resource type definition 211
  - sample configurations 211
  - Solaris 210
  - state definitions 210
- ProcessOnOnly agent
  - agent functions 213
  - attributes 214
  - description 212
  - resource type definition 214
  - sample configurations 215
  - Solaris attributes 214
  - state definitions 213
- Project agent
  - agent functions 235
  - attributes 235
  - description 234
  - resource type definition 236
  - sample configuration 236
- Proxy agent
  - agent functions 251
  - attributes 251
  - description 250
  - resource type definition 252
  - sample configurations 252

**R**

- RemoteGroup agent
  - agent functions 256
  - attributes 257
  - description 255
  - resource type definition 262
  - state definitions 256

- resource type definition 54
  - SambaShare agent 173
- resource type definitions
  - Application agent 199
  - CoordPoint agent 206
  - Disk agent 52
  - DiskGroup agent 32
  - DiskGroupSnap agent 43
  - DNS agent 140
  - ElifNone agent 265
  - FileNone agent 267
  - FileOnOnly agent 271
  - IP agent 86
  - IPMultiNIC agent 97
  - IPMultiNICB agent 113
  - LDom agent 232
  - Mount agent 67
  - MultiNICA agent 103
  - MultiNICB agent 124
  - NetBIOS agent 176
  - NFS agent 151
  - NFSRestart agent 158
  - NIC agent 91
  - NotifierMngr agent 248
  - Phantom agent 254
  - Process agent 211
  - ProcessOnOnly agent 214
  - Project agent 236
  - Proxy agent 252
  - RemoteGroup agent 262
  - SambaServer agent 171
  - Share agent 165
  - Volume agent 54
  - Zone agent 223
  - Zpool agent 77
- resources
  - description of 19
- RVG agent
  - described 272
- RVGLogowner agent
  - dependency graph 288
  - described 287
  - failover group 287
- RVGPrimary agent
  - dependency graph 276
  - described 276
  - migrating 276
  - takeover 276

- RVGShared agent
  - dependency graph 285
  - described 285
  - parallel group 285
- RVGSharedPri agent
  - dependency graph 292
  - described 291
  - migrating 291
  - takeover 291
- RVGSnapshot agent
  - described 282
  - fire drill 282

## S

- Samba agents 166
  - overview 166
  - prerequisites 166
- SambaServer agent
  - agent functions 168
  - attributes 169
  - description 168
  - resource type definition 171
  - sample configuration 171
  - state definitions 168
- SambaShare agent 171
  - agent functions 172
  - attributes 173
  - resource type definition 173
  - sample configurations 173
  - state definitions 172
- sample configurations 114
  - Apache HTTP server agent 190
  - Application agent 202
  - CoordPoint agent 207
  - DiskGroup agent 35
  - DiskGroupSnap agent 43
  - ElifNone agent 265
  - FileNone agent 267
  - FileOnOff agent 269
  - FileOnOnly agent 271
  - IP agent 87
  - IPMultiNIC 98
  - IPMultiNICB agent 114
  - LDom agent 233
  - Mount agent 72
  - MultiNICA agent 105
  - MultiNICB agent 128
  - NetBIOS agent 177
  - NFS agent 153

sample configurations *(continued)*

- NFSRestart agent 161
- NIC agent 92
- NotifierMngr agent 249
- Phantom agent 254
- Process agent 211
- ProcessOnOnly agent 215
- Project agent 236
- Proxy agent 252
- SambaServer agent 171
- SambaShare agent 173
- Share agent 165
- Volume agent 54
- Zpool agent 78

- scalar dimension 19

- secure DNS update 144

## Share agent

- agent functions 163
  - Solaris 163
- attributes 164
- description 162
- resource type definitions 165
- sample configurations 165
- Solaris attributes 164
- state definitions 164

## snapshots

- using RVGSnapshot agent for 282

## State definitions

- VolumeSet agent 56

## state definitions 133

- AlternateIO agent 238
- Apache HTTP server agent 181
- Application agent 195
- CoordPoint agent 205
- Disk agent 51
- DiskGroup agent 27
- DiskGroupSnap agent 38
- DNS agent 133
- ElifNone agent 264
- FileNone agent 266
- FileOnOff agent 268
- FileOnOnly agent 270
- IP agent 83
- IPMultiNIC agent 95
- IPMultiNICB agent 110
- LDom agent 227
- Mount agent 61
- MultiNICA agent 100
- MultiNICB agent 116

state definitions *(continued)*

- NetBIOS agent 175
- NFS agent 150
- NFSRestart agent 156
- NIC agent 89
- NotifierMngr agent 245
- Process agent 210
- ProcessOnOnly agent 213
- RemoteGroup agent 256
- SambaServer agent 168
- SambaShare agent 172
- Share agent 164
- Volume agent 53
- Zpool agent 74

- string data type 19

**T**

## takeover

- RVGPrimary 276
- RVGSharedPri 291

- trigger script 127

- trunking 81

- types.cf 19

**V**

## VCS

- resource types 19

- vector dimension 19

## virtual IP

- RVGLogowner agent requirement 287

## Volume agent

- agent functions 53
- attributes 54
- description 52
- sample configurations 54
- state definitions 53

- volume sets 34

## VolumeSet agent

- agent functions 55
- attributes 56
- State definitions 56

**Z**

## Zone agent

- agent functions 218
- attributes 219
- description 215
- resource type definition 223

**zones**

- resource attributes 20

**Zpool agent**

- agent functions 73

- attributes 75

- description 72

- resource type definition 77

- sample configurations 78

- Solaris attributes 75

- state definitions 74